

**centerpoint now**







sustainability?

### “Indifference: the worst attitude

It is true that the reasons for outrage today may seem less clear or the world more complicated. Who runs things? Who decides? It is not always easy to distinguish the answers from among all the forces that rule us. It is no longer a question of a small elite whose schemes we can clearly comprehend. This is a vast world, and we see its interdependence. We are interconnected in ways we never were before, but some things in this world are unacceptable. To see this, you have only to open your eyes. I tell the young: Just look, and you'll find something. The worst possible outlook is indifference that says, 'I can't do anything about it, I'll get by.' Behaving like that deprives you of one of the essentials of being human: the capacity and the freedom to feel outraged. That freedom is indispensable, as is the political involvement that goes with it.”

### Stéphane Hessel (1917-2013)

Excerpt from *Indignez-vous!* by Stéphane Hessel, Indigène éditions, October 2010  
[www.indigene-editions.fr](http://www.indigene-editions.fr)

Published in England under the title: *Time for Outrage!* (Quartet Books, London, translation by Damion Searls, with Alba Arrikha)

### “L'indifférence : la pire des attitudes

C'est vrai, les raisons de s'indigner peuvent paraître aujourd'hui moins nettes ou le monde trop complexe. Qui commande, qui décide? Il n'est pas toujours facile de distinguer entre tous les courants qui nous gouvernent. Nous n'avons plus affaire à une petite élite dont nous comprenons clairement les agissements. C'est un vaste monde, dont nous sentons bien qu'il est interdépendant. Nous vivons dans une interconnectivité comme jamais encore il n'en a existé. Mais dans ce monde, il y a des choses insupportables. Pour le voir, il faut bien regarder, chercher. Je dis aux jeunes : cherchez un peu, vous allez trouver. La pire des attitudes est l'indifférence, dire 'je n'y peux rien, je me débrouille'. En vous comportant ainsi, vous perdez l'une des composantes essentielles qui font l'humain. Une des composantes indispensables: la faculté d'indignation et l'engagement qui en est la conséquence.”

### Publisher's Note

# WCPUN

## World Council of Peoples for the United Nations

World Council of Peoples for the United Nations (WCPUN) dedicates this issue of CENTERPOINT NOW to a reflection on sustainability, human rights, peace, socio-economic and environmental justice and the consciousness to realize them.

We salute all who are engaged in offering their energy, insight, influence and commitment towards these aims.

CENTERPOINT NOW is a publication of the World Council of Peoples for the United Nations that highlights issues on the international community's agenda and showcases diverse perspectives, with a view to stimulating discussion and inspiring constructive action. Views expressed in CENTERPOINT NOW do not necessarily reflect those of WCPUN.

World Council of Peoples for the United Nations is a 501(c)(3) not-for-profit organization dedicated to facilitating partnerships across sectors internationally that promote awareness and implementation of the United Nations' goals. Through publications, workshops, dialogues, educational and outreach-oriented events, projects and programmes, WCPUN provides alternative think spaces to enable visionary people and organizations of diverse disciplines and expertise to connect and collaborate.

WCPUN is a non-governmental organization in association with the United Nations Department of Public Information.

© 2013 World Council of Peoples for the United Nations.

[www.wcpun.org](http://www.wcpun.org)



## A Note from the Editor

# Disappearance and Emergence

Shamina de Gonzaga



This issue of CENTERPOINT NOW began with discussions about how the meaning of “sustainable development” can vary according to who’s speaking and what one wants to “develop” or “sustain.”

To explore different people’s perspectives on the matter, especially as the UN community was gearing up for the 2012 “Rio +20” Conference on Sustainable Development, WCPUN/CENTERPOINT NOW collaborated with artists, like Barbara Holub, whose “Blue Frog Society: A Habitat without Territory,” invites participants to free ourselves from limited thinking and envision the “impossible” (a world without borders) through an artist’s lens. With Images and Voices of Hope and What Moves You?, we co-convened a series of interdisciplinary facilitated conversations considering intersections of media and sustainable development, with a focus on public engagement. In partnership with LCAconseil.net and the École Supérieure de Gestion et Commerce International, we invited students to apply their innovation and communication skills to formulate outreach strategies.

Over the course of these interactions, activists, architects, artists, designers, diplomats, engineers, entrepreneurs, journalists, philosophers, politicians and scientists shared their views, some of which are reflected in the pages that follow. Other featured input emerged as the process of working on the publication began to unfold.

We are immensely grateful to all who have so generously shared their work with us, especially Michael Najjar whose artwork is featured on the outside and inside covers of this issue, and Jeppe Wikström of Aday.org for the images from A Day in the World, which appear at different junctures in this journal; to WCPUN members Alexandra Abrams, Gema Álava, Nina Colosi, Charles Koo, Renaud Rédien-Collot, Peri Uran, and Xavier Xargay, who introduced us to new sources of inspiration and collaboration; to the sponsors whose contributions enable this not-for-profit endeavor to come to fruition; to the Design team whose creative work makes the publication come together as a whole; and to the readers, for your interest.

The diversity present in CENTERPOINT NOW is intended to broaden the scope of what might be considered pertinent to the theme—in this case, the concept of “sustainability.” Where do questions of sovereignty, cultural identity, and globalization fit in when we speak about “sustainability?” Can societal behaviors that are generally considered “unsustainable” be modified to contribute towards generating solutions? How can trauma be transformed into strength? Recognizing what’s obsolete, and what forgotten or suppressed wisdom can be recalled or restored, rather than focus on what we’re up against, what tools do we possess to see and function in new realities? We don’t purport to “have answers” or provide a comprehensive overview of topics that are vast and complex. Our aim is to advance new insights and partnerships so that what is ready to change doesn’t stay the same, in our minds, and in the world we co-create.

Shamina de Gonzaga, CENTERPOINT NOW Editor-in-Chief, is the Director/Main Representative to the UN for World Council of Peoples for the United Nations (WCPUN) and Co-founder of What Moves You?

info@wcpun.org

### Publisher

World Council of Peoples for the United Nations (WCPUN)  
Sherrill Kazan Alvarez de Toledo, President

### Editorial

Editor-in-Chief, Shamina de Gonzaga  
Senior Editor, Marcia Marin Retrey  
Junior Editors, Katharine McGehee, Samuel Weinberg

### Design

Creative Director, Gala Narezo  
Lead Designer, Sarah Alfarhan  
Designers, Jon Dicus, Karla Saldaña, Niral Parekh

### WCPUN Expresses Gratitude to the Following Sponsors for their Generous Support:

Zeckendorf Development, LLC., Arthur Zeckendorf, William Lie Zeckendorf  
Mutual of America, Thomas Moran  
Wings of Hope  
Toy2R Limited, Raymond Choy  
Mr. Kong Tai  
Hospitality Holdings, Inc., Mark Grossich  
Forvets Chocolates Corporation, Anthony Stone  
The Family School  
A Living Library  
Rory Staunton Foundation  
DZI Design Group  
Aesop Realty

### Additional Support from:

Augustinian Canons of Saint Patrick’s Church, Glen Cove NY  
Wine Consultant Group, Locust Valley NY, Carlos A. Taborda  
O’Halloran Foundation  
Rockefeller and Co.  
Sorgente Foundation  
7FCornerstone  
Fortuna Fine Arts Ltd.  
The Merrin Gallery  
Michelle Picard

### Special Thanks for the Collaboration of:

Aday.org/Expressions of Humankind Foundation, Jeppe Wikström, Linda Grahn, Marcus Erixson; Buckminster Fuller Institute, Allegra Fuller Snyder, David McConville; Cindy Byram PR; David Lynch Foundation, Austin Ayer; Dwyer Cultural Center, Cliff Frazier, Jannette Hawkins, Ademola Olugebefola, Ed Sherman; École Supérieure de Gestion et Commerce International, Oliver Sercq, Michaël Vasseur, Alexis Donnio, Stanislas Gérard, Pauline Boukhecha, Brice Fleuri, Davina Lukenga, Laurent Pauc; Estate of R. Buckminster Fuller, John Ferry; European Union External Action Service, Christopher Matthews; FC Barcelona, Ketty Calatayud; Foster + Partners, Lord Norman Foster, Brandon Haw; French-American Foundation, Thibault Charetton; Fundació Pau Casals, Nuria Ballester, Mrs. Marta Casals Istomin; Generalitat de Catalunya, Dr. Jordi Monés, Joan Maria Piqué, Jordi Ribes, Clara Tarrida; Geto & de Milly, Michele de Milly; Images and Voice of Hope, Wendy Bromley Bodden; Indigène Editions, Sylvie Crossman; Japan Society, Miwako Tezuka, Masako Shiba, Cory Campbell; LCAconseil.net, Professor Dr. Marcel Saucet; Novolo Networks, Geri Dempsey; Smithsonian Institution, Paula T. DePriest, Ph.D.; Streaming Museum, Nina Colosi; Studio of Michael Najjar, Michael Najjar, Patricia Röder; The Tent Project, Joan C. Roth; United Nations Correspondents Association; University of San Diego, Professor Dana Robinson, Rexford Brabson, Bill Gallox, Jon Jekel; Vanderbilt YMCA

### Friends and Associates:

Katz Abe, Ismail Acar, Selcuk Acar, Barbara Ammirati, Joshua Arnow, Chantal Line Carpentier, Dan Qing Chen, Naiara Costa, Zelma Davis, Angela Dong, Juan Esteban, Estelle Fasquelle, Chantal Fischzang, Nathalie Franques, Ruy García, Sofia García, Vicente García Delgado, Brandon Himmel, Jeffery Huffines, Ozgur Madak, Tommy Markowski, Jonathan Marx, Kenneth McClure, Mercedes M. Mier, Yolanda Mier, Marnie Muller, Martin Olavarrieta, Dr. John Pai, Gilbert Retrey, Céline Roche Crespo, Ozlem Sahin Sakar, Shining Sung, Yohei Suzuki, Alberto Vasquez, Michaela Walsh, Joshua Young

**WCPUN Board of Directors:** Dra. Sherrill Kazan Alvarez de Toledo; Nina Colosi; Aaron Etra, Esq.; Shamina de Gonzaga; Dr. Charles Koo, PhD., MH; Mansour Lavi; Dr. Luis Felipe G. Prumbs, MD; Dr. Al Orensanz, PhD; **International Advisers:** Dr. Charles Koo, PhD., MH – Hong Kong, China; Renée Niño de Rivera – Mexico; Dr. Renaud Rédien-Collot, PhD – France; Asst. Prof. Dr. Peri Uran, PhD – Turkey; **Cultural Advisers:** Gema Álava – Spain; Kóan Jeff Baysa, M.D. – US; Barbara Holub – Austria; Gala Narezo – US/Mexico; **Environmental Advisers:** Rupert Pollard – UK; Bonnie Ora Sherk – US; **Adviser for Partnerships:** Xavier Xargay; **Leadership Development:** Amy Su Zhang; **Youth Advisers:** Alexandra Abrams – UK; Alexandra Bonvalot – France; Ebi Spahiu – Albania



**002** Excerpt from *Indignez-vous!* by Stéphane Hessel

**003** Publisher’s dedication, World Council of Peoples for the United Nations (WCPUN)

**004** Editor’s Note, Disappearance and Emergence, Shamina de Gonzaga

**005** Contributors

**008** Making the Invisible Visible, by Allegra Fuller Snyder and David McConville

**010** The Role of “Major Groups” in Achieving “The Future We Want,” by Chantal Line Carpentier, Ph.D.

**011** The NGO Major Group Speaks Out on Sustainable Development Goals, by Jeffery Huffines and Leida Rijnhout

**012** Overcoming “Eco-Apartheid,” a Conversation with Vandana Shiva, by Sanjeev Chatterjee

**014** Advancing Change, by Felix Dodds

**015** Climate Change, Peace and Security, by Kumi Naidoo

**016** A Day in the World, Photo by Akinleye Akintunde

**018** Insights from the United Nations Forum on Forests: An Interview with Jan McAlpine

**020** Climate Change Migration in Africa, by Andrew Mambondiyani

**022** Making Sense of What’s at Stake: A New Human Rights Principle for Sustainable Development Governance, by Gaston Meskens

**023** Creating a World Where Each Child Can Thrive: SOS Children’s Villages Vision for Sustainable Development, by Dr. Gitta Trauernicht

**024** Human Rights Principles and Practice, an Interview with International Woman of Courage, Safak Pavey

**026** The Gender Agenda at the UN, by Janet Z. Karim

**028** Sustainable Development that Leaves No One Behind, by Cristina Diez

**029** Why Animals Matter in Achieving “The Future We Want:” A Message from the World Society for the Protection of Animals

**030** A Day in the World, Photo by A. M. Ahad

**032** Holistic Thinking at Work: The Sustainability Laboratory and Project Wadi Attir, with Dr. Michael Ben-Eli

**034** Art as a Path: an Interview with Mariko Mori

**036** Documenting Change in Antarctica, with Andrea Juan (Español/English)

**041** Streaming Museum, by Nina Colosi

**042** Perspectives on Policy, a Conversation with European Commissioner for Sustainable Development, Andris Piebalgs

**044** The Blue Frog Society: A Habitat without Territory, by Barbara Holub

**046** Transitions in Time, A Conversation with Artur Mas, President of the Generalitat de Catalunya (Español/English)

**051** Culture and Conviction, The Legacy of Pau Casals

**052** ‘Més Que Un Club,’ an Interview with FC Barcelona President, Sandro Rosell (Català/English)

**056** A Day in the World, Photo by REZA

**058** Basque Society in the 21<sup>st</sup> century, with Iñigo Urkullu, Lehendakari / President of the Basque Government (Español/English)

**061** Creating an Ecosystem for Excellence in Leadership, by Elizabeth Filippouli, Global Thinkers Forum

**062** Globalization and Identity, with Mikel Markez and Eñaut Elorrieta (Español/English)

**064** An Appeal for Debate, with Historian, Julián Casanova (Español/English)

**067** Green Growth for the Baltic Sea, by Katharina Brecht with Sten Björk

**068** The EU and Turkish Cypriots: Development without Democracy? by Lucia Najšlová

**070** Art After Technology, with Maurice Benayoun

**072** Behind the Barriers, a Conversation with Dr. Izzeldin Abuelaish, MD MPH

**074** *Into Sunlight:* Sustaining Movements for Peace, by Rhea Lehman, PhD

**076** When are “Sustainability” Benchmarks Unsustainable? An Interview with Teru Kuwayama

**078** Thoughts on Sustaining the World’s Cultural Heritage, by Robert J. Koestler

**080** The Beauty of Balance—Wenzhi Zhang and the Renaissance of Lacquer Painting

**082** Capoeira: Freedom and Tradition, with Mestre Kiki da Bahia

**084** Cándido Camero and Carlos del Pino: Cuban Music across Generations and Genres

**086** Musical Roots in Motion—The Journey of Malika Zarra

**087** Ademola Olugebefola: Legacy of a Living Artist

**088** Las Plañideras and Our Last Tears, by Antonio Briceño (Español/English)

**090** Tell Me, by Gema Álava

**091** A Digital Storyteller, a Message from Native American Hip Hop Artist, Frank Waln

**092** A Day in the World, Photo by Yereth Jansen

**094** The Future of Ancient Seeds, an Interview with Dr. Sarah Sallon

**096** Ancient Culture and Modern Business in Austria’s Stift Klosterneuburg Wine Estate, with Wolfgang Hamm

**098** Riding Along the Ups-and-Downs of Brazil: What Lies Ahead? A Conversation with Marcos Troyjo

**099** Blurring the Line between Species: Eduardo Kac and the “Natural History of the Enigma”

**100** Intricacy and Depth, The Work of L. Mylott Manning

**101** The New Money, A Conversation with Jem Bendell, by Nina Rennie

**102** Emerging Women Entrepreneurs and Sustainable Business in Yucatan, Mexico, by Isabel Peña Alfaro

**104** Harnessing Luxury-Spending Power, by Nina Rennie

**105** A Creative Key to Success—Raymond Choy and the Qee, by Samuel Weinberg

**106** Wings of Hope: Beyond Agendas, by Douglas Clements

**108** Sustainable Development as an Idea, by Ebi Spahiu

**110** Visual Media for Social Change, by Sanjeev Chatterjee

**111** I’m Design Thinking About You, by Gala Narezo

**112** Biogeometry: The Science that Should Shape the World, by Ahmed Tarek Wafik

**113** Masdar City, Abu Dhabi, United Arab Emirates, by Foster + Partners

**114** Serve: The Ultimate Black Book Vol. 1, by Zoe Himmel

**116** Choice and Circumstance, a Dialogue with Wes Moore

**117** What Moves You? by Shamina de Gonzaga and Gala Narezo

**118** A Day in the World, Photo by Q. Sakamaki

**120** The Spirit of Endurance, with Oliya Clarkson

**122** Youth Making a Difference: Past, Present and Future, by Cliff Frazier and Jason Higgins

**124** A Day in the World, Photo by Björn Larsson Ask

**126** Healing Through Music and The Power of Thought, with Mr. Kong Tai

**127** Meditation and Sustainability, by David Lynch

**128** Rory’s Legacy: Combatting Sepsis and Saving Lives Through Education and Awareness, by Kathy Thompson

**130** “Is there a doctor on board?” by Kóan Jeff Baysa, M.D.

**133** The Evolution of the Social Brain, by Allan Young

**134** A Healthy Epigenetic Lifestyle à la Croatia, by Koraljka Gall Troselj, MD, PhD

**136** Trial and Triumph, the Mission of Noriko Inamori

**137** Yogis Beyond Borders, by Dr. Elaine Valdov

**138** Hope, Peace and a Magical Ride, the INTRA Experience, by Kathy Thompson

**140** Accessing Other Realms: Joan C. Roth and The Tent Project

**140** The World Genesis Foundation

**141** Energy Medicine for Cancer, with Dr. Mayra Rodríguez-Mohamed

**142** Meditation at the United Nations, featuring perspectives from Jan Eliasson, Kusumita Pedersen, Pragati Pascale, and Samuel Leal

**144** The United Nations Correspondents Association

**145** 50 United Nations Plaza: A New Global Address for the United Nations Community

**146** The World Bar and Dag’s Café

**147** Sharing the Legacy of Dag Hammarskjöld Plaza: Friends of Dag Hammarskjöld Plaza

**148** A Living Library, by Bonnie Ora Sherk

**149** The Family School—Developing Global Citizens in the Spirit of Maria Montessori, by Lesley Nan Haberman

**150** International Young Leaders Vision Summits, by Dr. Elaine Valdov

**151** The Society of Young Philanthropists, by Alexandra Abrams

**152** Coming Together for Veterans: Joining Hands to Make a Nutritional Difference

**153** Transforming the experience of war into a platform for peace, by William C. Needham, Jr.

**154** Live, love and...dine out! The New York State Latino Restaurant Association, by Juan Esteban

**155** The Hispanic Information and Telecommunications Network: Empowerment through Educational Media and Entertainment

**156** Aesop realty—A Spirit of Service

**157** DZI Design Group

**158** About A Day in the World, by Marika Stolpe and Jeppe Wikström

**159** Colophon

**160** Cover Artist Statement, by Michael Najjar



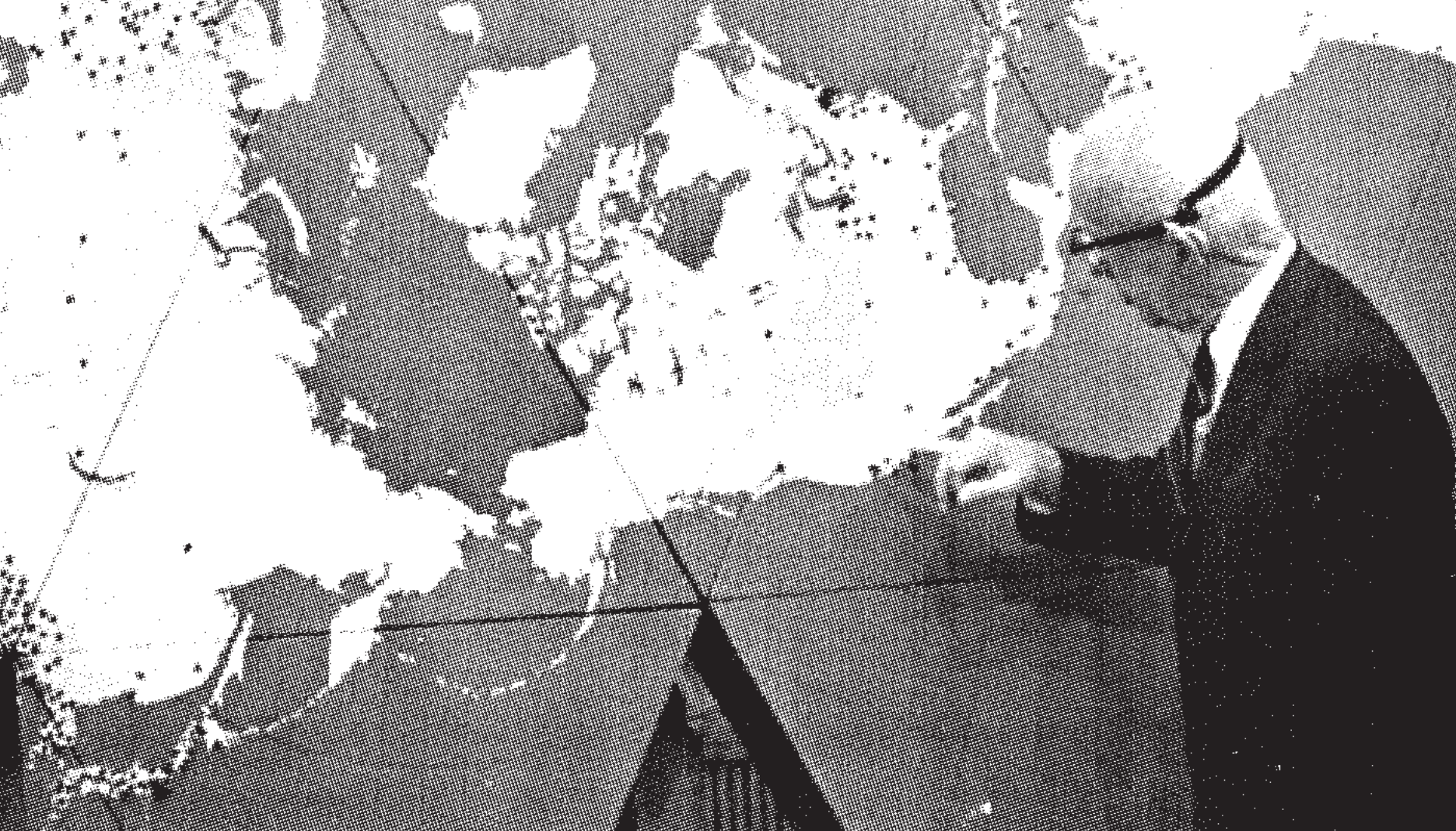

# Making the Invisible Visible

by Allegra Fuller Snyder and David McConville

Allegra Fuller Snyder, Buckminster Fuller's only child, is an Honorary Member, Board of Directors of the Buckminster Fuller Institute; Professor Emerita of Dance and Dance Ethnology, UCLA; former Chair, Department of Dance; and founding Coordinator of the World Arts and Cultures Program.

David McConville, current Chairman of the Board of the Buckminster Fuller Institute, is a media artist, researcher, and entrepreneur who designs tools for seeing the world in new ways.

[www.bfi.org](http://www.bfi.org)

Decades before the term “sustainability” entered the cultural lexicon, R. Buckminster Fuller sought to illuminate the interconnected challenges facing humanity. During the 1930s, he began charting long-term trends relevant to industrialization and globalization. This seminal work demonstrated the value of visualizing the relationship between world resources and human needs.

To better visualize patterns of global change, Fuller proposed that a spherical Earth display—called the Geoscope—be installed outside of the United Nations and other public facilities. In this passage, he describes how the Geoscope might function:

*“The consequences of various world plans could be computed and projected, using the accumulated history-long inventory of economic, demographic, and sociological data. All the world would be dynamically viewable and picturable and radioable to all the world, so that common consideration in a most educated manner of all world problems by all world people would become a practical event.”*

*Education Automation (1962)<sup>1</sup>*

Fuller envisioned the visualization of global datasets over time as a powerful tool for playing what he called the World Game. The World Game's bold purpose statement invites players “To make the world work, for 100% of humanity, in the shortest possible time, through spontaneous cooperation, without ecological offense or the disadvantage of anyone.” (Fuller & McHale, 1963)<sup>2</sup>

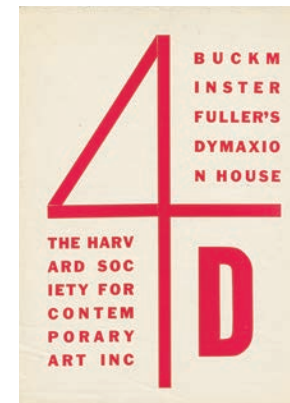
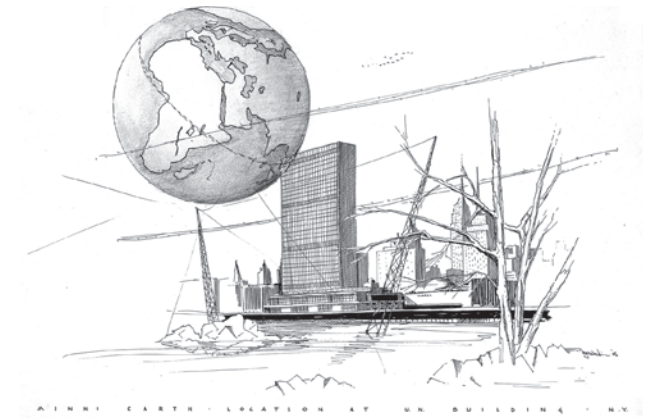
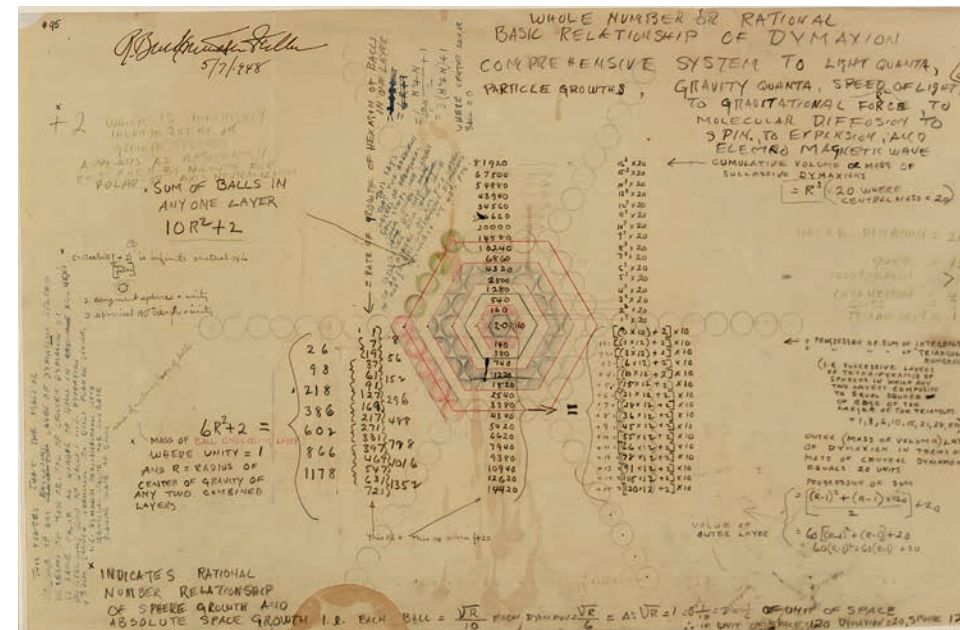

Anticipating the arrival of digital cartography and scientific visualization displays, Fuller proposed a Geoscope Mini Earth be installed outside of the United Nations. He envisioned that this would allow UN delegates to envision metabolic flows of energy, food, water and military movements around the globe.

Sketch, right: Sketch by Winslow Wedin (1956) of Buckminster Fuller's Minni Earth Location at UN Building 4, New York City [Courtesy of the Estate of R. Buckminster Fuller].

Photo on opposite page: scanned by Gene Keyes from cover of *World Game Report*, [28 p.], ©1969, Edwin Schlossberg. Photography by Daniel Gildesgame and Herbert Matter.

Images on this page except for Winslow Wedin Sketch courtesy of The Estate of R. Buckminster Fuller.

Informed by an elegant set of design principles, the World Game challenges players to “start with the whole” and “anticipate the future.” The goal is to employ existing resources and know-how in order to raise the standard of living for all.

The use of the word “game” in the title is instructive, illustrating Fuller’s approach to whole systems thinking and creative problem solving. Though intended as a serious tool, Fuller chose to call the initiative a “game” because he imagined a process open to everyone. Well before its time, Fuller was an advocate of “open source” design. He envisioned a tool that was available to the widest possible audience with its findings widely disseminated to the public. As solutions were proposed and tested, a groundswell of public support would influence the political process to adopt the strategies and innovations of those playing the democratically open World Game.

Today, many of the technologies Fuller anticipated are woven into the fabric of our society, including computer networks, simulation games, and scientific visualizations. Many “Digital Earth”<sup>3</sup> initiatives (ISDE, 2013) are now working to apply these new technologies to make visible the intimate interconnections between economic, social, and ecological health.

The Buckminster Fuller Institute is dedicated to connecting these initiatives with a new generation of design scientists working to create an abundant, restorative, and regenerative world that benefits all of humanity.

[1] Fuller, R. B. (1962). *Education Automation: Freeing the scholar to return to his studies; a discourse before the Southern Illinois University, Edwardsville Campus Planning Committee*, April 22, 1961. Carbondale, IL: Southern Illinois University Press.

[2] Fuller, R. B., & McHale, J. (1963). *World Design Science Decade, 1965-1975*. Carbondale, IL: Southern Illinois University.

[3] International Society for Digital Earth. (2013). Retrieved from [www.digitalearth-isde.org](http://www.digitalearth-isde.org)



# The Role of “Major Groups” in Achieving “The Future We Want”



by Chantal Line  
Carpentier, Ph.D.

In June 2012 more than 40,000 people—including parliamentarians, mayors, UN officials, chief executive officers and civil society leaders, as well as more than 50 heads of state and close to 500 ministers—attended the Rio+20 Conference on Sustainable Development, which made it one of the largest international conferences in recent history. Moreover, more than 700 commitments in the amount of \$513 billion were pledged to build a sustainable future, signaling a major step forward in achieving the future we want.

The event followed from the Earth Summit in 1992, also held in Rio de Janeiro, during which countries adopted Agenda 21—a blueprint to rethink economic growth, advance social equity and ensure environmental protection. Other important achievements included landmark treaties on climate change, biological diversity and desertification and an agreement on forest principles.

Agenda 21 recognised that “One of the fundamental prerequisites for the achievement of sustainable development is broad public participation in decision-making.” For the first time the UN defined nine sectors of society known as “Major Groups” as being critical to the achievement of sustainable development in cooperation with Member States: Women, Indigenous Peoples, Children and Youth, NGOs, Workers and Trade Unions, Local Authorities, Business and Industry, Science and Technology Community, and Farmers.

To fulfil this mandate, the UN established a Major Groups programme within the newly created Commission on Sustainable Development (CSD) charged with following up on the implementation of Agenda 21. During the last twenty years, the Major Groups have been given a seat at the table at the CSD to hold governments accountable in the development and implementation of policy, to develop partnerships and showcase

best practices from government, civil society and business.

At Rio+20, countries renewed their political commitment to the development of a green economy in the context of sustainable development and poverty reduction, agreed to establish a set of Sustainable Development Goals (SDGs), and established a high-level political forum on sustainable development, which included provisions for enhancing the engagement and consultation of Major Groups and other key stakeholders. Rio+20 did not elaborate specific goals but stated that the SDGs should be limited in number, aspirational and easy to communicate. The goals should address, in a balanced way, all three dimensions of sustainable development and be coherent with and integrated into the UN development agenda beyond 2015.

The UN General Assembly subsequently created an Open Working Group that will develop SDGs to become a part of the Post-2015 Development Agenda to replace the eight Millennium Development Goals (MDGs) adopted by the UN in 2000 to reduce poverty in half by 2015. The Major Groups and other stakeholders from around the world have been invited to participate in the deliberations of the Open Working Group to offer their recommendations for the SDGs and Post-2015 Development Framework, based on the principles of sustainable development and lessons learned from the MDGs process.



Chantal Line Carpentier, Ph.D., is the Major Groups Programme Coordinator, United Nations Department of Economic and Social Affairs.

[www.sustainabledevelopment.un.org](http://www.sustainabledevelopment.un.org)

# NGO Major Group Speaks Out on Sustainable Development Goals

The MDGs have increased international coordination between states and other developmental actors. They have brought together public, private and political support for global poverty reduction and provided an effective tool to stimulate the production of new poverty-related data and additional aid commitments. In some countries they have provided tools for civil society and other development actors to participate more effectively. It is important that the post-2015 process — both in its design and its implementation — builds on this momentum to further strengthen the voice of civil society organisations at all levels.

Nevertheless, the MDGs failed to address the root causes of poverty and of the lack of progress on realising human rights. We need a shared vision of just, equitable and sustainable societies in harmony with nature in which every person can realize their human rights, based on common responsibilities, wellbeing and a life free from poverty. This will require a dramatic shift to a new development paradigm requiring a holistic and coherent approach linking development and environment, with the full and effective participation of civil society at all levels to ensure that leaders make the right decisions.

The Brundtland Report (1987) posited that “Sustainable development is development that meets the needs of the present without compromising the ability of future generations to meet their own needs.” According to the same report, the above definition contains within it two key concepts:

*“The concept of ‘needs,’ in particular the essential needs of the world’s poor, to which overriding priority should be given; and the idea of limitations imposed by the state of technology and social organization on the environment’s ability to meet present and future needs.”*

This is crucial, since science reports with increasing certainty that our human society is at the border of nine planetary boundaries that includes climate change, ocean acidification, ozone depletion, freshwater use, land use, biodiversity, chemical pollution, and nitrogen and phosphorus cycles.

What has become patently clear is that business as usual is not an option. Sustainable development requires a paradigm shift and most of the existing policy strategies and institutional bodies are still in the old paradigm of supporting unlimited growth, large scale, intensive and global production schemes, privatization of the commons, creating a debt-based economy. Sustainable development requires meeting the basic needs of all and extending to all the opportunity to fulfil their aspirations for a better life by fairly distributing natural resources within and among nations. It is important to stop all trends and policies that support the unsustainable patterns of production and consumption. It is simply no longer credible to imagine that richer countries can continue their patterns of over consumption, while also encouraging others to do the same.



In order to develop the future SDGs for the achievement of sustainable societies, where wellbeing and dignity of all is secured, lifestyles within the limits of the ecological capital are established, equality is the norm and life in all its forms and expressions is treated with respect, NGOs propose that the SDG/ Post-2015 framework will be structured as follows:

- An overarching, global consensus stating the vision of sustainable development and the values that should guide policies and actions outlined in the framework.
- Accountability of progress made: all goals will need clear and bold targets, indicators, timetables and review mechanisms.
- Democratic governance and implementation: all countries have already agreed on defining a National Strategy for Sustainable Development (NSSD).
- Sources of finances for the SDGs have to be clear from the start: there needs to be the integration of the SDGs in overall policy goals (NSSDs); the national budgets for achieving those goals have to be defined at national levels.
- Policy coherence between (inter)national policies and institutions: it is crucial that while implementing the SDGs there is a continuous coherence policy check among national ministries and multilateral institutions responsible for the implementation of the three dimensions of sustainable development: that includes economic development, social inclusion and environmental protection.

In short, the SDGs are not so much about new commitments, but primarily about ambitious means and targets and strong political will to implement what has been already agreed by national leaders since 1992.

Photos on opposite page, top: Exhibits, Events on Sustainable Development Hosted at Rio+20 Pavilion UN Photo/Maria Elisa Franco. Bottom: Scenes from Rio +20 UN Photo/Guilherme Costa. Photo on this page: Sustainable Development Hosted at Rio+20 Pavilion UN Photo/Maria Elisa Franco.

Statement provided by NGO Major Group Organizing Partners, Jeffery Huffines, CIVICUS UN Representative (NY), and Leida Rijnhout, Executive Director, ANPED Northern Alliance for Sustainability.

[www.civicus.org](http://www.civicus.org)  
[www.anped.org](http://www.anped.org)



# Overcoming Eco-apartheid:

## An Interview with Vandana Shiva

by Sanjeev Chatterjee

“I think the real shift in sustainability is taking place through a shift in worldview.”

**Why don't we start by talking about your latest book, *Making Peace with the Earth*?**

*Making Peace with the Earth* really grew out of my Sydney Peace Prize lecture that was on the same theme. There are really two things that I have tried to address in the book. The first is the current stage of globalization, which is highly resource intensive and highly predatory. It can only move to the next stage by destroying democracy through militarized form. The violence and war against the earth will get intensified, and so will the wars against people. The book is full of my own involvements in these wars against the earth and wars against people. But the book also talks about the amazing new thinking emerging around the world—a new confidence among indigenous people and indigenous cultures that the set of systems that ruled, whether economic paradigms or political paradigms, have all got their roots in Eurocentric narrowness. One of the assumptions that came

from Europe was the idea that the earth is dead. She's just dead matter available for limitless exploitation. Every culture throughout most of history has seen the earth as a living mother. Movements such as what came out of Bolivia—I worked with the team on the drafting of the *Universal Rights of Mother Earth*—are creating another imagination and allowing new possibilities to grow, not just among indigenous communities and cultures, but also among people who are facing the collapse of the US, Europe and other parts of the world.

**You have been variously called a philosopher, a scientist, a feminist, an environmentalist.... Where do you see your real impact to be?**

In a totally unintended area of seed and food. Sometimes they even think I am an agronomist! I have never, ever had even a single class is agronomy (laughs), and it's very interesting how

these labels get attached to you. Not because of what you were trained in, but because of the fields to which you have contributed. So I am often called an economist because I have made so many critiques of the globalized economic model. But I think my real impact has been in the thinking and acting in the issues around seed and food, and changing that paradigm. In everything else, I will make a policy impact, or I will make a scientific impact, but because of Navdanya, besides the shift in worldview, we have been able to create a shift in practice. I think that really makes for a bigger impact.

**The conversation about sustainability has been going on for quite some time now. But what are the tools that have been developed to actualize sustainable practices?**

I think the real shift in sustainability is taking place through a shift in worldview. Because, if we maintain our relationship with the earth as a relationship of the exploiter, as a relationship of the master and the conqueror, then there will be tools that will constantly fail. That's why, in *Making Peace with the Earth*, I talk about going beyond the eco-apartheid, the solution of separation that then allows the justification of domination. I have called the new worldview Earth Democracy—putting Gaia, the Earth, at the center of our thinking and knowing we are part of the earth and not separate from her. The old paradigm is separation; it is eco-apartheid. And in that old paradigm, the earth is an epistemic separation, everything is fragmented, everything has to be broken up. One of the most curious debates taking place is how synthetic biology—extreme genetic engineering—has already given us so many failures and unknowns. There was just a conference in Cambridge called the “Future of Nature” about engineering life being the only way to protect species. Now, isn't that an absurd conclusion? To destroy life is to create life and conserve it! And that's because the tools of sustainability are being shaped in that destructive worldview. Sustainability tools must be derived from a philosophy. And the philosophy must be, first and foremost, a philosophy that sees there are limits set to human activities, because of the fact that this planet is not just for the human species.

**There seems to be a lot of confusion now about the old paradigm where people and institutions felt bound to the boxes of their own disciplines and sectors while newer thinking promotes empathy and cross-sector bridging. From your perspective, where are the opportunities for bridge building and where are the most difficult roadblocks?**

They are artificial boxes, and they are all vertical boxes. They are silos and we need to turn them into bridges. You have to break the silos and build them into bridges to see the interconnectedness because there is too much artificial divide. Nothing is just one thing. So this idea of essential, immutable properties, characteristics around which all our politics got shaped, is the big block and we have to go beyond it because everything is connected.

The opportunities are the bounties of biodiversity. Everything flows from there. And through biodiversity there is an opportunity to start realizing that indigenous cultures have had all the knowledge of the world. Part of the subjugation of indigenous societies has been by defining them as ignorant, as not having knowledge; that the science of conquest was the only kind of science. And we are in that moment of history where the science of belonging, the science of interconnectedness, is the highest form of science, coming not only from ancient cultures, but also from the cutting edge on science that is not manipulated by corporate interests. So, biodiversity is a huge, huge, opportunity and I'll give you a very simple example: Bill Gates has poured \$15 million on genetically

engineering bananas. So here's one man with lots of money, financing one Australian scientist who knows one crop, the banana. He doesn't know anything else. If you brought him ragi, he wouldn't recognize it. Bringing this as a solution to iron deficiency in Indian women. So here is the insanity of the capitalistic patriarchal worldview. Rich man and narrow-minded scientist parading around the world saying “we will solve all the problems” and “we are your benefactors.” The opportunity it gives us is we now can talk about real solutions to iron deficiency. We can talk about all our indigenous biodiversity. We can talk about Indian foods and the cultures of balance. We can talk about the fact that we always ate chutneys with our greens so that iron could get absorbed. And when that goes out of your diet, you can eat all the iron, but it won't get absorbed. There is an opportunity to bring women center stage to show that they are the knowledge keepers in these fields of what is good nutritious food.

What are the blocks? The blocks are the fact that there is big money and stupidity. There is big corruption imposing bad ideas on the world. The combination of corruption and the profit motive is what drives scientists to lock themselves into these false solutions, and what locks in policy makers despite evidence that they're not working.

**You have spoken elsewhere about the capitalistic patriarchal society. I am wondering what may be good examples of female leadership in the world? Not only women, say as the keepers of biodiversity at the village level, but also about women leaders. Margaret Thatcher, who passed away recently, comes to mind, and we can certainly name other women who came to very powerful positions in their lives. What was missing in their leadership?**

What was missing is, as people have said, Margaret Thatcher was “the best man in the team....” They tried to be more uncompassionate than their male counterparts. They tried to be more violent; they tried to promote more selfishness than their male counterparts. That's what was wrong. I think there is a whole new generation of leaders not with the iron fist that the ‘Iron Lady’ had, but with much more compassion and ability to build strength around compassion.

**For young women, within the context of sustainability, who are the role models?**

When I wrote *Staying Alive*, or later with Maria Mies my book *Ecofeminism*, it was becoming extremely clear that when it came to real serious environmental issues, women could emerge as leaders. Whether it was Love Canal and Lois Gibbs, or women in Russia after Chernobyl, or in Japan, after the Fukushima disaster. Women rise. I have been working with American groups on the whole GMO issue, the labeling and now the Monsanto protection acts... mothers are going to be marching across the US turning the July 4th marches into food-freedom marches for the labeling of GMO foods. So I think there is a whole new leadership of a different kind emerging. And it is a leadership around the protection of life, defending the common good, thinking of the larger whole.

Sanjeev Chatterjee is a teacher and mediamaker focusing on global documentary work. He was the founding Executive Director of the Knight Center for International Media at the University of Miami from 2007-2011 and served as the Vice Dean of the School of Communication, University of Miami.

Vandana Shiva defies categorization. She has been called a philosopher, author, environmentalist, activist, scientist, economist... the list can go on. Her life's work has been to fight for the rights of the earth and its peoples. Her latest book is *Making Peace with the Earth* (Pluto Press, 2013). She has won many international awards and accolades. She won the Sydney Peace Prize in 2010. Dr. Shiva is the founder of Navdanya, a network of seed keepers and organic producers spread across India.

www.navdanya.org



# Advancing Change

by Felix Dodds

Four major developments since the 2012 Rio+20 UN Conference give us hope that we may be starting to address the environmental and developmental challenges in front of us.

On a structural level, the Conference advanced the need for change in the global institutions for the environment and sustainable development. The United Nations Environment Programme became a body with universal membership, allowing it to be seen as the global voice for the environment. In the area of sustainable development, Rio+20 agreed to close down the United Nations Commission on Sustainable Development (CSD) after 20 years of experimentation. The CSD experienced some success in its first ten years but progress stalled recently with the Commission meeting in 2007 and 2011 failing to produce any outcome. In its place, governments have created a High Level Political Forum that will meet every four years at the Heads-of-State level. Ultimately it is designed to be the forum from which monitoring of 2015's new development goals will emerge. The second major outcome since Rio+20 is the agreement to have a set of Sustainable Development Goals (SDGs) which would be universal in nature, reaching every country and putting sustainable development and poverty eradication at its center. By jumpstarting this process, Rio+20 changed the development paradigm. Now, all governments will have to address sustainable development in their policies and practices... or at least they will after 2015. It is already clear what themes some of those goals will center around: water, energy, food, education, health and employment. It's not yet clear if gender and governance will be self-standing goals, cross-cutting targets, or both. Other possible goals being considered included cities, oceans and seas, disaster relief, forests, and environmental sustainability.

The third outcome from Rio was a major discussion on the green economy. Although controversial in some circles, it did engage government finance ministries in the discussion on sustainable development. One result from this engagement is found under the World Bank on Natural Capital where 65 countries and companies are running parallel Natural Capital accounts. This already looks like a very important development, a fact underpinned by the speeches from both the head of the World Bank and of the IMF at the first meeting of the new High Level Political Forum in September 2013.

Additionally, Rio+20 recognized the challenge this and future generations will face with regard to Planetary Boundaries. Scientists under Johan Rockström at the Stockholm Resiliency Center identified nine Planetary Boundaries we need to monitor and three boundaries we are already exceeding: climate change, biodiversity, and nitrogen. Rockström's modeling will inform future policy decisions as more and more information makes it clearer what tradeoffs may be needed to keep within these boundaries.

The immediate focus for many people, beyond climate change, is in the areas of Food Security-Water Security-Energy Security, and the Nexus between these. In November 2011, Germany hosted a major conference on the Nexus in Bonn. The follow-up conference will be in March, 2014, in Chapel Hill, North Carolina. As climate change impacts on water availability and food and energy production, the question becomes, what can we do to address these issues as joint challenges?

Felix Dodds, Chair of the 2011 UN DPI/NGO Conference "Sustainable Societies - Responsive Citizens," is a Fellow at the Global Research Institute at the University of North Carolina and an Associate Fellow at the Tellus Institute in Boston.

[www.felixdodds.net](http://www.felixdodds.net)

[www.earthsummit2012.blogspot.com](http://www.earthsummit2012.blogspot.com)



# Climate Change, Peace and Security

by Kumi Naidoo

UN Secretary-General Ban Ki-moon said in 2011 that climate change "not only exacerbates threats to international peace and security", but that climate change "is a threat to international peace and security". Let's take the conflict in Darfur, Sudan. In 2007, the UN General Secretary argued that the conflict started as "an ecological crisis, arising at least in part from climate change". Prolonged drought in Sub-Saharan Africa has led to water and food scarcity, increasing tensions and fueling conflict over resources. History will judge Darfur as a conflict triggered by climate change.

The science is clear and scientists agree that climate change will increase the likelihood of extreme weather events, including droughts, floods and super storms. There is no doubt that climate change is facilitating more extreme weather events—which will lead to a loss of lives and livelihoods, either because of natural disasters, or over time.

The question I often ask is: what are our governments doing about our fossil fuel addiction and the inherent dangers of runaway climate change. The biggest threat to peace and security is the collusion of our governments with certain industry interests. Last year \$1.75 trillion was spent on the world's military, according

to a study released by the Stockholm International Peace Institute earlier this year. Seems like a lot? Another report released earlier this year by the International Monetary Fund revealed that worldwide subsidies to fossil fuels total \$1.9 trillion annually. Almost 9% of all annual country budgets are spent on supporting oil, natural gas and coal industries.

We need a paradigm shift—and there are clear signs all over the world that people are demanding real change and that they are willing to pour into the streets to fight for their rights: the Occupy movement, the Arab Resistance movement and more recently the Gezi Park movement in Turkey and the Roşia Montană movement opposing cyanide based gold mining in Romania. I am hoping that peaceful protests against governments protecting industry interests at the expense of their own people will increase in magnitude and reach. I believe we are well underway for a paradigm shift. And civil society, the environmental movement—including Greenpeace—are starting to reflect this.

*Kumi Naidoo, Greenpeace International Executive Director and Greenpeace volunteers take to the streets and join with over a thousand climate activists, NGO members and other representatives demanding urgent climate action from the delegates at COP17.*

© Shayne Robinson / Greenpeace

[www.greenpeace.org](http://www.greenpeace.org)





# A DAY IN THE WORLD

**Bayelsa, Nigeria, 13:15.**

*Men ferrying stolen crude oil to an illegal refinery, revealed by the smoke in the background, along Diebu Creek. Oil production in Nigeria has been reduced by thieves siphoning off supplies from unguarded pipelines. The illegal industry is estimated to be worth hundreds of millions of dollars a year.*

*Photo by Akinleye Akintunde.*

[www.aday.org](http://www.aday.org)  
© Max Ström



# Jan McAlpine,

*Director of UNFF to share her perspective.*

## **Could you describe your trajectory, what led you to work on forests?**

I was drawn to work on forest-related issues because of their multi-sector, multi-policy implications. I started my career at the Water Environment Federation, whose members deal with water pollution control, and later worked with the U.S. Environmental Protection Agency and the Office of the U.S. Trade Representative in the Executive Office of the President (of the United States). In the Office of Trade and Environment, I was the lead negotiator on Timber trade, as well as on tobacco trade and health trade issues. I learned a great deal about how language alone could be the barrier in resolving conflicts. At the U.S. State Department, I worked on various projects, including for the 2002 World Summit on Sustainable Development, and helped form The Congo Basin Forest Partnership (CBFP), which was announced by then Secretary Colin Powell in Johannesburg. The CBFP continues to operate to this day as a structure to help countries implement sustainable forest management, and where donors can choose the mechanisms through which they provide financing.

At the United Nations, I worked with colleagues to get the issue of illegal trade introduced into UN language. The policy objective at the time was to get illegally logged timber banned for import. International pressure pushed for an international definition of what constituted illegality. The US and other countries insisted that it had to be violation of a domestic law, in line with the Rio Forest Principles, which stipulate that unlike air or water that move between countries, trees are rooted and therefore under the authority of one government. From Rio to the present, the affirmation is that countries therefore have the sovereign right to sustainably manage their trees and forests.

## **Where do we stand now in terms of the protection of forests?**

We've taken off into hyperspace in many ways. Governments that were totally ignorant about sustainable forest management are now very much aware. Developing countries know the insides and outsides of those issues. Incentive systems have helped motivate governments to change their behavior. As is often said, Western countries used all of our trees and industrialized, so how can we tell developing countries not to use theirs? There's a lot of truth to that. Western countries were negligent in the past and now want protection. Especially as climate change became the focus, we have concentrated on not cutting down trees and forests. Many NGOs have favored this stance and pressured governments. On the other side of the equation, how can you say to a mother: "I'm sorry, you can't cut down that tree to cook food for your child, because that tree's really important for the global climate...?" Balance is crucial. Sustainable development requires a focus on economic development, on social issues, and on environmental protection. All three need to be addressed simultaneously.

## **Are the initiatives that compensate countries financially in exchange for not deforesting viable?**

The question is, "do they have permanence?" And the answer is, "yes and no." The big question we are now addressing is the intersection between economic development and forests. Forest managers, alone, cannot accomplish sustainability. Forests are too heavily impacted by outside sectors, such as transportation, mining, or agriculture, the latter of which is by far the largest cause of deforestation.

### Photos:

1. *Sleeping beauty*  
by Pablo Pro (Spain)
2. *Pahmung krui Damar Forest*  
by Eka Fendiaspara (Indonesia)
3. *My favorite place*  
by Olga Lavrushko (Ukraine)
4. *Morning from Situ Gunung*  
by Prasetyo Nurramdhan (Indonesia)
5. *Budur* by Atakan Baykal (Turkey)
6. *Faces of the Mau: Community Leader* by Riccardo Gangale (Italy)

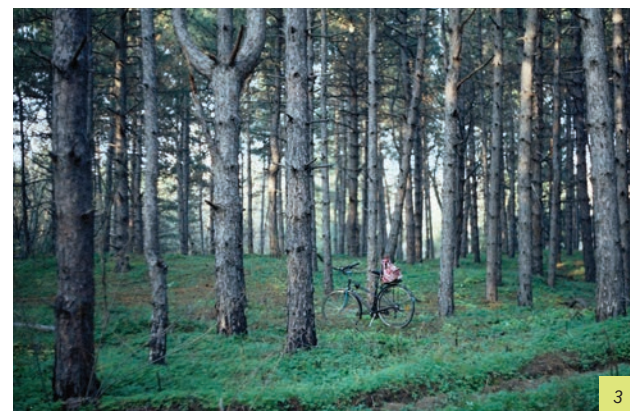

Not only crops, but also cattle are causing forests to be cut in developing countries because of consumer demands for that food, particularly in developed countries. So, how can we change the architecture of financing for forests? One of the challenges with donors, especially when an economic downturn occurs, is that they suddenly run out of money, or significantly scale back their budgets and cut the funding to many of their projects. If the donor builds in a system that is self-sustaining and allows the country to protect, as well as use its resources, then such initiatives can succeed. At the UNFF we established the Collaborative Partnership on Forests with 14 international organizations that work together on a voluntary basis to examine the issues in their complexity. We work together on a voluntary basis to address these issues and it has paid off in ways we never anticipated. Much remains to be done. These issues, including the subject of sustainable financing for sustainably managed forests, will be a big part of the focus in 2015 when the UN reviews the International Arrangement on Forests.

## **What space do you envision for forests in the Sustainable Development Goals (SDGs)?**

Of the two proposals for SDGs relating to forests, one is a "Forest SDG." That option has pros and cons; one downside is that, if forests get an SDG, what about water, energy, and other issues? The objective is to agree on a small number of SDGs, as with the MDGs, so as to achieve maximum impact. The other option being promoted, and which I support, is a "Natural Resource Sustainable Development Goal," as part of a cluster of crosscutting goals. For example, one goal that will clearly carry over from the past MDGs is about poverty eradication. It hasn't been achieved. Forests play a big role in that. Forests influence whether or not rural people stay rural, or move to urban areas. For Indigenous Peoples, who are generally not in charge of their own natural resources, including forests or trees, their livelihoods depend greatly on forests and trees for medicine, clean water, and energy. We understand that 1.6 billion people depend directly on forests for a variety of these necessities. All 7 billion of us depend on forests for our lives. Addressing that is central to sustainable development overall.

## **What inspires you to continue working in this field? How can your message reach everyone regardless of their level of exposure to forests?**

I really want to have a positive effect on people. Having been raised in Africa, I understand more than many Westerners about the need for a balanced approach. When we focus on economic development, we need to make sure we're addressing rural communities, as well as urban ones. We need incentives for rural people to stay in rural areas if they're happy to do so. If you remove incentives to protect forests, people are much more likely to go to an urban area for income. We have seen that pattern repeatedly. In terms of reaching people, I think NGOs have a huge role in helping to familiarize citizens with the importance of nature. But, to some extent, I'm not sure every citizen has to be familiar for us to target the people and change the policies that will make the most difference. In my future career, I will be working with other members of academia to look at the gaps in knowledge and at more effective strategies to advance implementation of what world governments have promised. And I still find sitting in the forest one of the most relaxing and fulfilling things to do.

[www.un.org/esa/forests/](http://www.un.org/esa/forests/)





# Climate Change Migration in Africa

by Andrew Mambondiyani



Though various statistics have been bandied around, it is clear that more than three million people from Zimbabwe have sought refuge in South Africa in the past decade. However, contrary to the widely held notion that most of these refugees are political migrants, a large number are environmental or climate change refugees.

Zimbabwe's economy is agro-based, but over the past decade, the country has experienced devastating droughts and floods, making agriculture unviable. Experts have linked these natural disasters to climate change. Millions of poor villagers who depended on subsistence agriculture currently face hunger and famine. Although there are various other factors that could force people to migrate, according to the United Nations Environment Programme (UNEP), it is now increasingly recognized that environmental degradation and climate change have been among major drivers in both forced and voluntary migration.

Climate change threatens to cause one of the biggest refugee crises of all time and climate change experts have warned that

up to 200 million people would be forced to abandon their homes over the course of the century.

My research over the past five years has revealed that the high number of people migrating from Zimbabwe to South Africa is linked to climate change and the past decade of devastating droughts that Zimbabwe has experienced. With more than 80 percent of the rural population in Zimbabwe depending on agriculture, the droughts have been catastrophic, forcing thousands of poor people to join the 'great trek' to South Africa in search of employment.

There has also been a significant rise in pests and diseases for crops and livestock in the country, putting an even greater strain on the agricultural sector, which is already reeling under the effects of persistent droughts. Some people in low-lying areas, such as the Zambezi and Limpopo valleys, have abandoned their homes due to perennial floods. A Zimbabwean migrant worker, who only identified himself as Chamu for fear of being deported by South African authorities, told this reporter in an interview

in the small South African town of Giyani, that he was not running away from political persecution like others from Zimbabwe, but because he could no longer sustain his family through agriculture: "I was a small-scale farmer in the Chivi area in Masvingo province in Zimbabwe, but for the past ten years rainfall has been unpredictable making agriculture unviable. I came here looking for a job and I am happy that I got one. However, I am working and living here without proper immigration documents."

Fidelis Zvomuya, a renowned climate change journalist based in South Africa, weighed in, adding that farmers in Zimbabwe were no longer employing as many workers as before due to persistent droughts, resulting in people crossing borders to look for employment in neighbouring countries. Zvomuya added: "The lack of food in areas like Matabeleland provinces in Zimbabwe, where droughts are now an annual event, is forcing people to cross to South Africa for jobs."

Migration as a result of climate change is not isolated to the Southern parts of Africa alone, but extends to the whole continent. The Horn of Africa has experienced one of the worst climate change-induced famines in more than half a century, forcing people to seek refuge in countries like Zambia, Zimbabwe and South Africa. Millions of people have been affected and their respective governments, as well as humanitarian organizations, have been caught off guard. Countries in the region were not prepared for such a devastating famine and the massive movement of people. Although migration can be a positive and a useful way to adapt to climate change, there are many situations in which it is not a viable option.

Poverty, failing ecosystems, vulnerability to natural hazards and gradual climate-driven environmental changes have been linked to migration. Despite the gravity of the challenge, it seems African governments are not taking climate change-induced migration seriously. Experts say climate change is expected to significantly affect migration in three distinct ways. First, the effects of warming climate and droughts in some regions will reduce agricultural potential and undermine the provision of clean water and the availability of fertile soil. Second, the increase in extreme weather events such as heavy rains and resulting flash or river floods in tropical regions will affect even more people and generate mass displacement. Third, sea-level rise will permanently destroy extensive and highly productive low-lying coastal areas that are home to millions of people who will have to relocate permanently.

While the consequences of mass migration are not de facto negative, its main impacts overwhelming are. These include escalating humanitarian crises, rapid urbanization and associated slum growth, and stalled development.

But are African countries, poor as they are, prepared for this impending disaster? Most countries are ill prepared for the mass movement of people as a result of climate change, both internally and across national borders. The mass movements have resulted in conflicts among people as they fight for resources.

These conflicts as a result of climate change migration have been evident in some parts of Zimbabwe where people are moving in

large numbers to regions in the Eastern Highlands, which are still receiving significant rainfall. In the Burma Valley area, which forms part of the Eastern Highlands in Zimbabwe, there have been serious conflicts between people who have invaded the rich farming area and the local inhabitants. The newcomers have forcibly resettled themselves close to the sources of two major rivers in the area and have diverted the water to irrigate their own crops, starving the original settlers who are living downstream.

"These squatters have caused a lot of problems for us. They have invaded our water sources and we are no longer getting enough water for our banana plantations," Josphat Manzini, a successful banana farmer in Burma Valley said. "We have tried to engage them and the government to no avail and the multimillion dollar banana farming business in the valley is under threat," he added.

Across the border in South Africa, the massive influx of labor migrants has resulted in serious conflicts in the country—a horrific example being the xenophobic attacks in South Africa of June 2008. Although Southern African Development Community (SADC) member countries signed a protocol on the facilitation of movement of people within the region in 2005, these countries do not have comprehensive plans for the integration of migrants in their countries.

West of Zimbabwe, in Namibia, one of the worst famines has wiped out livestock for the semi-nomadic herders in the northern parts of the country. The pastoral existence of the Ovahimba people in Namibia is under threat with the herders moving as far as 200 kilometres looking for pastures and water for their livestock. In the same region, the Zemba people, who depend on growing crops, have not been spared either, with some villagers leaving for the city to seek employment.

In Southern Africa, a region that has suffered a number of climate-induced disasters in recent history, notably the flooding in the Zambezi Valley in Mozambique, Zimbabwe, and in Namibia's Caprivi region, and droughts across the region, experts, such as Mukundi Mutasa, agree that climate change migration is urgent to discuss.



Photos by Andrew Mambondiyani. Left: Falling pastures are forcing herders to migrate in search of new pastures and water for livestock.

Right: One of the new homesteads on the banks of a stream in the eastern highlands of Zimbabwe.

Andrew Mambondiyani is a Zimbabwean journalist who reports extensively on political, environmental, agricultural and mining issues in Zimbabwe from the land reform program to illegal gold and diamond mining in the country. He has been a Knight Science Journalism Fellow at Massachusetts Institute of Technology (MIT) and an inaugural Fellow at the Middlebury Fellowship on Environmental Journalism in the USA.

[www.east24.wordpress.com](http://www.east24.wordpress.com)



# Making Sense of What’s at Stake

*A new human rights principle for sustainable development governance*

by Gaston Meskens

How can we speak meaningfully about the relationship between sustainable development and human rights? I join the many critical voices that claim that an economic logic ‘with ecological and social corrections’ can never ensure sustainable development in itself. In other words: human rights and societal wellbeing should not be considered corrective factors, but rather central normative drivers for sustainable development. In that sense, sustainable development is impossible without a continuous care for the protection and implementation of human rights. On the other hand, we need to acknowledge that a ‘full implementation’ of human rights would not automatically lead to sustainable development.

A fair and effective approach to sustainable development challenges will always be troubled by the difficulty of negotiating a consensus that integrates and balances reasonable, but often incommensurable and conflicting interests. Not only do we have to deal with the complexity of acquiring knowledge about those systems and their relation to our natural and technical environment, we also need to take into account the fact that our global challenges are essentially cases of moral pluralism. That is: even if we would all agree on the knowledge base of a specific sustainable development-related problem, opinions could still differ about the acceptability of proposed solutions. Indigenous knowledge and the natural and social sciences can inform us about the character of options, they cannot always clarify the choice to make. Moral pluralism thus requires us to acknowledge that, in many cases, we have to deal with limits to knowing of problems and solutions and with a plurality of opinions on problems and solutions.

Whether we think and act as citizens, scientists, entrepreneurs, activists or policy makers, all concerned actors need to engage in forms of knowledge generation and decision making that enable societal trust primarily by virtue of their open, inclusive and deliberate method, instead of the rationality of their envisaged solutions. In my research, I argue that this view comes down to a critical-deliberative approach to the use of knowledge and value-based reference in governance, which translates as:

. Policy supportive knowledge generation that, by spirit and method, is trans-disciplinary and inclusive and  
. Governance that, by spirit and method, is inclusive and process-oriented, and that also methodologically enables and enforces transparency with regard to actors’ intentions and interests.

Sustainable development relies as much on human individual and collective creativity as it relies on human individual and collective responsibility. In this respect, we should be aware that there will always remain a vague line between what should be ‘enforced’ in the interest of human rights, human equality and human solidarity on the one hand, and what should be ‘left open’ to contingent dynamics relying on the power of individuals and communities to employ creativity, commitment and solidarity on the other.

Reflections on boundary conditions in sustainable development discourse usually refer to planetary boundaries and to how considerations on these boundaries inform our normative thinking about sustainable development itself. But if sustainable development requires intellectual confrontation of the rationales we use to justify our socio-economic behavior, to what extent could and should ‘reference rationales’ that ‘reach beyond’ or ‘play from outside’ of the socio-economic context serve as

political, social or cultural boundary conditions to sustainable development? To illustrate this consideration, one can wonder whether (and how) rationales in support of economic growth, state sovereignty, military defense capacity, freedom of human reproduction, or the protection of the integrity of collective regional, cultural or religious identities need to be deliberated in the interest of sustainable development, or whether (and why) these rationales rather set the fences of its playing field.

Although these examples are different and even incomparable in nature, one may observe from the global political negotiations concerned with sustainable development, their specific related themes (energy, water, health, etc.), and crosscutting issues (climate change, poverty, etc.) that

. These rationales figure as either positive, neutral or negative references in sustainable development discourse, depending on who is using them;  
. For each of them, support for both views (‘need to be deliberated’ versus ‘set the fences’) exists;  
. But also that deliberate reflection on these issues and on their meaning for sustainable development governance is missing in formal political negotiation processes devoted to sustainable development.

We all need to become ‘cosmopolitans beyond comfort zones’ by providing ourselves with the critical-intellectual capacities to engage in intellectual confrontation. Sustainable development, as a collective human responsibility, also implies specific individual human rights with regard to ‘knowing,’ ‘expressing opinions’ and ‘decision making.’ In other words, human rights for sustainable development are not only about combatting poverty and providing equal access to basic needs and justice, but also about having equal access to the kind of knowledge generation and decision making that recognizes limits to knowing and plurality of opinions, and that, ‘in the face of complexity,’ aims to make sense of and give meaning to the world, ourselves and the issues at stake.

Therefore, in addition to the three fields of human rights that concern a fair socio-economic organization of our society, (namely: 1. the equal right to aid and access to justice of those in need today; 2. the equal right to have access to and to participate in the socio-economic dynamic and to deliberate adverse effects of that socio-economic dynamic; 3. the equal right of those of the future to govern their own needs), I propose a ‘human rights principle for sustainable development governance’ that consists of the equal right for every human to contribute to making sense of what is at stake. This right can be fulfilled through the implementation of a three-fold concept of ‘distributive justice’:

1. *a sharing of effort in intellectual capacity building*  
(‘nobody can do it alone’) [*> implying pluralist and reflexive basic and advanced education and inclusive and trans-disciplinary research as policy supportive knowledge generation*]
2. *a sharing of deliberative space*  
(‘nobody should do it alone’) [*> implying inclusive, deliberative multi-level decision making*]
3. *a sharing of freedoms of collective choice*  
(‘even all together, our deliberative power is limited’ in face of the contingent future) [*> implying global governance as a continuing process of engagement and intergenerational accountability*]

Societal trust requires organized intellectual confrontation; intellectual confrontation requires organized intellectual solidarity. Condensed in one thought, we can say that, this human rights principle enables what is essential for human well-being and what makes sustainable development governance really possible: the right to be responsible for every human.

Gaston Meskens, Centre for Ethics and Value Inquiry, Faculty of Arts and Philosophy, University of Ghent (Belgium) is a theoretical physicist, researcher in moral philosophy, and artist.

[www.the-possibility-of-global-governance.net](http://www.the-possibility-of-global-governance.net)

# Creating a World Where Each Child can Thrive

*SOS Children’s Villages’ Vision for Sustainable Development*

by Dr. Gitta Trauernicht

Vice President, SOS Children’s Villages International

Development starts with one child, one mother, one family that lifts itself out of poverty to rise above its circumstances. Throughout my career as an academic, politician, board member and Vice President of SOS Children’s Villages, I have experienced first hand, what a difference safeguarding the rights of children, women, and families, makes to society.

Achieving social justice is arguably the greatest challenge facing humanity today. Nevertheless, I truly believe that by creating a world where each child can thrive, we build the foundation of a just and equitable society, and thereby foster the conditions for sustainable development. To create this world, we must all begin by focusing our efforts on supporting and uplifting those children who are the most vulnerable, the most marginalised, and who would otherwise remain condemned to a lifetime of poverty. We must make sure that no child is left behind.

Drawing upon both my personal experience and that of SOS Children’s Villages, with over 60 years of work in countries across the globe, I can say with regrettable confidence that children who grow up without parental care or who risk losing this care are amongst the most vulnerable and marginalised groups of children. Without nurturing families to adequately protect them, they often lack even the most basic social and economic support. They are at increased risk of poverty, marginalisation, stigmatisation, violence and neglect.

Children without parental care or whose families are at risk of separation often suffer the most unspeakable trauma resulting from abuse, disease, armed conflict or natural disaster; yet, they are less likely to receive the quality health care they need to overcome their physical and emotional scars. These children are less likely to go to school and more likely to drop out when they do attend; and as young people, they have fewer opportunities to get a decent job or make living wages. Children in institutions often suffer from poor health, developmental delays and emotional attachment disorders; yet they are more likely to grow up without ever receiving the care they need or knowing what it is to have a loving bond to a caregiver.

In order to thrive, all children and young people, especially these most vulnerable and marginalised, have a right to receive quality care. This implies not only that their basic needs are met—including health, education, and nutrition—but that each and every child experiences the stable and loving relationships that are so vital to a healthy personal development. As a society, we must be able to uphold that right. On the one hand, we must support parents and caregivers to provide a nurturing and protective family environment for their children, thereby tackling the root causes of family separation and preventing so many of the problems that exacerbate poverty and inequity. On the other hand, we must ensure that children in alternative care, such as foster families, SOS families or residential arrangements, receive the quality care they are entitled to so that they too can grow into confident, self-reliant adults and contributing members of society.

At SOS Children’s Villages, we believe in every child’s right to quality care and we know that this can only happen in a caring family environment. During my years of service to the organisation, I have seen our co-workers support parents during the most difficult of circumstances, helping to keep families together. I have also had the privilege to witness the unique care that SOS Children’s



Villages provides to children who can no longer live with their families. By getting to know each child we work with individually and recognising his or her unique circumstances, SOS Children’s Villages caregivers and co-workers can help each and every child to develop a long-term plan for their development and support them on their way.

Recently, I learned the story of a boy who grew up in an SOS family in Ethiopia. He came to SOS Children’s Villages when he was only eight years old; separated from his family, his future was not bright. Safe and nurtured in an SOS family, however, he was able to enjoy his childhood and grow into a secure and confident young man. As a teenager, he started tutoring his brothers and sisters, and at a young age decided that teaching was his calling. Together with his SOS caregiver and his social worker, he made a plan for his development and they began to work towards that plan. Today, this young man is attending Harvard University, having obtained a full scholarship, after which he is planning on returning to his native Ethiopia. Of his experience at Harvard, he says, “it will give me lifelong skills to make changes in my community after my university life.” This young man’s story proves to me, as so many other individual stories have, that we can change society, one child at a time.

By creating a world where all children and young people can thrive, we help them to overcome their harsh circumstances and shape their own futures. Through appropriate quality care, we create the conditions for the most vulnerable and marginalised children to grow into adults who break the cycle of poverty and inequity not only for themselves, but for their own children and their communities; we are not only investing in the next generation, but also in a future society that is just and equitable, and that can foster sustainable development.

*Photo courtesy of SOS Childrens Villages.*

[www.sos-usa.org](http://www.sos-usa.org)





# Human Rights Principles and Practice

CENTERPOINT NOW invited *International Woman of Courage* awardee, *Turkish Parliamentarian*, and *Founding Member of the UN Interagency Support Group for the Convention on the Rights of Persons with Disabilities*, Safak Pavey, to comment on the way forward for the implementation of human rights and sustainable development.

## **What motivated you to pursue a political career?**

I am not a career politician and I hope never to become one. I have been concerned for a number of years with the cultural fault line that cuts across all segments of my country, but I had never planned to be part of the political process. It was a very quick and sudden decision that came about following an offer from the Social Democratic main opposition, with a very short deadline for me to respond. At the time, I was a UN staff member at the Office of the High Commissioner for Human Rights in Geneva and I was passionately committed to my work related to UN human rights treaties. When the offer came, I had to decide in a matter of hours. Such a dramatic change in my life may appear strange, but for a dynamic society like Turkey, it's very normal. I strongly believe in putting our efforts towards good governance with transparency and accountability. This is only possible through a participatory democracy, where healthy public debate takes place with governmental criticism and with the opposition. My country, through very significant and costly reforms, tried very hard to modernize and establish a modern lifestyle for its citizens, moving beyond the conflicts of a bygone era. My goal has become to remind my country of these ideals and to help it move along this path.

## **Having worked internationally, and now as a Parliamentarian in Turkey, how do you perceive the representations of Turkey in the West?**

In my experience, Western institutions seem to have rather low expectations of a truly representative, 21<sup>st</sup> century democracy in Turkey. And they hold great influence in the international arena. I am wholeheartedly against the notion that argues, 'this is the best we can expect from Turkey.' The higher we aim, the closer we will come to that mark. We should not let our ideals be worn down so easily. I know that a 21<sup>st</sup> century democracy is only possible within a secular system that respects and embraces all differences. And Turkey is still the most probable candidate to respond to the global need of reconciling tradition, secularism and democracy. This reality should encourage us to continue in our journey of progress as a modern society. The only way we can do this is if we are held to the highest ceiling of international human rights standards, as an equal member of the international community.

## **What aspect of human rights do you believe are critical to address in this century? Could you also comment specifically on the status of the implementation of rights of people with disabilities?**

As a member of the 90s generation, I would like to personally thank the human rights defenders and states involved in realizing the Vienna Declaration and Programme of Action (VDPA), which is celebrating its 20<sup>th</sup> anniversary this year; we have greatly and directly benefited from the path you have opened for us as children, women, people with disabilities, and minorities of the time. Thanks to the VDPA, today's young people also have the chance to relate to participatory democracy through new mediums for freedom of expression, including social media. I know that back when the VDPA was being discussed, there was a sense of pessimism; the divisions seemed almost impossible to overcome. However, the agreement on the Vienna Declaration and Programme of Action emerged as a major achievement. The consensus of the 171 States participating in the Conference was welcomed and accordingly the mandate of the UN High Commissioner for Human Rights was created. It was a strong message to the international community and civil society that a consensus could be reached on human rights. It helped establish new references in human rights and paved the way for better human rights implementation and monitoring. I find it striking that it was at all possible to adopt such a declaration. VDPA has played a very important role in making "discrimination" unacceptable and shameful at the level of States. Although there may be many difficulties faced in its implementation at the national level, respecting human rights turned into a core value of States and became a condition for being a part of the international community.

In the past 20 years, developments within the international community have strengthened multilateral human rights actors and procedures. Many countries have accepted Human Rights as a less controversial issue in foreign policy agendas. Civil society, including NGOs, disabled persons organizations (DPOs), and human rights defenders, have become increasingly significant in the political landscape. However, human rights still provoke political controversy. Despite significant progress, the record of national practice leaves much to be desired. There have been, and are still, too many serious human rights violations that remain inadequately addressed or unaddressed by the international community.

Global economic and financial crises, climate change, diminishing food and clean water resources, poverty, gender inequality, the growing power and influence of emerging states are all factors that will likely have a deep influence in shaping the future implementation of human rights globally. As states think about the implementation of universal human rights at the national level, they face difficult questions to resolve. However, we can't just leave it to legislation. Speaking as a lawmaker, I see a much stronger challenge than that of changing national laws to comply with international law: The resistance of traditions. I am very often faced with the underlying thought that is deeply embedded in various societies, which questions fundamental freedoms, saying that "traditions, not freedoms, give meaning to one's life." I believe the main challenge we will be facing in the next two decades will be to reconcile freedoms and traditions. It is not the States that need a consensus now; it is cultures and traditions. For instance, let's look at the ongoing phenomenon of acid attacks against women following rejection of marriage, resisting sexual abuse, or in the context of family disputes. In some countries where this is a big human rights issue, lawmakers have developed and passed concrete laws, introducing severe penalties to fight against it. However, the number of women who are attacked with acid either remains the same, or increases in some cases. This is because legislation is not supported by parallel cultural campaigns to make this unacceptable amongst the members of the society who are following tradition, not the law. Cultural willpower is often stronger than political or legal willpower. What do we do if the law enforcement officer personally believes that the victim actually had a role to play in the crime?

In other corners of the world, child soldiers are recruited or child brides are wed, having been bought from their families. There is no trace of forceful recruitment or marriage. The families and receivers all seem to be in agreement. Then, whom do we struggle against? My answer is that we struggle against a "deep culture" which sees this as acceptable. We are still battling with the prejudices, discriminations and hate crimes of the past. We must remove these burdens from the shoulders of future generations. We need to focus more on cultural campaigns and consider making that a benchmark for participatory democracy. Perhaps, parliamentarians and governments should be responsible for formulating cultural campaign plans, along with human rights related legislation.

In my opinion, we do not need more legal development on the normative side, and should focus instead on the implementation of what has already been adopted through education and accountability. We can use Human Rights semantics as a reference and structure for standards of behavior, what should be considered acceptable treatment of human beings and social, governmental criticism.

As for the United Nations Convention on the Rights of Persons with Disabilities (CRPD), which enshrines concrete recommendations for prompt national level action and the monitoring of implementation for persons with disabilities to enjoy their human rights, the

biggest challenge faced in its implementation is no different than for any other human rights area. The resistance of the tradition that finds disabled people sinful is no different than the discrimination that considers stealing girls' right to education acceptable! Erasing prejudices from our perspectives through focused cultural campaigns is what we need to focus on the most.

## **What do you view as paramount to achieving "sustainable development?"**

The key question for development today is whether it is sustainable or not. The Millennium Goals gave rise to hope around the world, that we were at a stage where we recognized the importance of collective action. Humanity and our planet are going through a critical time when both human welfare and nature are undergoing fundamental changes. Any negative outcomes will be the direct consequences of our actions. Development and growth should not mean stealing the right to life, water, or a healthy natural environment. I am not convinced that the world as a whole has demonstrated that it grasps the seriousness of the threats we face. We are in a state of urgency where we need to think seriously about giving nature its rights, rather than defining it as our property. This century is currently witnessing the rise of values and principles through different struggles for rights and freedoms. And amongst these higher ideals, I strongly believe in recognizing "the rights of nature" just as we recognize human rights. We, as human beings, cannot exist without clean air, water, and food. So, we will either learn to co-exist with nature, or we will lose together with nature. The rights of human beings and nature are actually interconnected. There are good practices appearing in different parts of the world in this respect. For instance, Ecuador was the first country to recognize the rights of nature in its constitution. This was such a great precedent-setting practice in recognizing the legal rights of different life forms in our ecosystem that it became an inspiring model for young politicians to build upon. Last year, we presented the proposal for an ecological constitution to the parliamentary committee responsible for the formulation of the new civil constitution of our country, together with NGOs and my colleagues in the main opposition. We truly hope that we can achieve this and inspire others to follow this movement of defending human rights and nature's rights together.

Safak Pavey is known for her international work in the fields of human rights, humanitarian aid and peace-building. The train accident she had whilst studying in Zurich left her with one arm and leg, introducing her further to the issues confronting people with disabilities, and strengthening her resolve to advocate for the rights of all people whose rights are frequently neglected or violated. Safak Pavey is a member of the Turkish parliament, representing Istanbul province for the main opposition party, CHP.

[www.safakpavey.com](http://www.safakpavey.com)



# The Gender Agenda at the United Nations



by Janet Z. Karim

On 2 July 2010 in what has been called an historic move, the United Nations General Assembly adopted resolution 64/289, voting unanimously to create a new entity, UN Women, to accelerate progress in meeting the needs of women and girls worldwide. UN Women merged four previous UN gender entities—Division for the Advancement of Women (DAW); International Research and Training Institute for the Advancement of Women (INSTRAW); Office of the Special Adviser on Gender Issues and Advancement of Women (OSAGI); and United Nations Development Fund for Women (UNIFEM), as it had become evident that these entities, acting independently of each other, with scarce human and financial resources, had little or no muscle to move the gender agenda forward within the UN system, let alone globally. Recognizing the UN's role historically in making notable leaps for the advancement of women, many would wonder, why rock the boat? While commending the progress the UN had made thus far, for example with the International Conference on Population and Development (ICPD) Programme of Action, the Convention on the Elimination of Discrimination Against Women (CEDAW), or the Beijing Platform for Action, there was a critical need to “bring together resources and mandates for greater impact.”

Upon the adoption of the resolution, the four previous entities issued a joint statement welcoming the establishment of the UN Entity for Gender Equality and the Empowerment of Women (UN Women). They stated: “UN Women will be a dynamic and strong champion for women and girls around the world, providing them with a powerful voice at the global, regional and local levels. Its establishment will boost the United Nations’ ability to support and work with Member States in accelerating progress towards achieving the goals of gender equality and the empowerment of women, expanding opportunity and tackling discrimination against women and girls. UN Women will work with the entire UN system, and will forge effective partnerships with all stakeholders, including with civil society and women’s organizations....”

But this outcome, which formed part of the UN reform process and incorporated themes such as funding, governance and coherence of the UN System, was not achieved overnight. Rather, it was the culmination of lengthy consultations among Member States, the UN System, civil society and other special interest and political groupings, meeting frequently over a period of four to five years.

As a diplomat for the Permanent Mission of Malawi to the United Nations, I had the opportunity to be involved in that process. When I was first posted to the Mission, my former Permanent Representative, His Excellency Ambassador Steve Matenje, SC, assigned me to cover the “Third Committee” of the General Assembly, which deals with issues of Social Development, and also instructed me to look out for meetings on a process known as “System-Wide Coherence,” which was aimed at reforming and improving coordination among the various UN system agencies and programmes at the country level. I was to become an expert on all issues relating to the theme and to be the eyes and ears for the Mission of Malawi on this topic. Thus began a long journey through the corridors of intergovernmental negotiations on UN reform. I attended many meetings within the larger body of the General Assembly; as well as Group of 77 and China (G77), the African Group, and Southern African Development Community (SADC) Group meetings. However, the invitations to discussions (taking place noticeably during the lunch break), on what would become of the four gender organs of the UN, were what enveloped me. The discussions were short, intense, and many times required the participation of members of the four entities and, once in a while, that of the Deputy Secretary General and other officials from the UN secretariat.

Several years of lunch breaks, and some evening meetings and receptions were held among like-minded member states like the US, UK, France, China, Japan, Chile, Tanzania, Nigeria, Malawi, South Africa, Netherlands, Republic of Korea, Norway, Australia, Canada, Germany and others to evaluate progress being made in the negotiations on the recommendations that had been issued by the High Level Panel. After resolving to form a composite gender entity, questions were discussed including how to handle the four gender organs of the UN system, obtain the legality to disband them, the mandate to absorb their mandates, manage current staff of the organs, the overall future of management and functions of the entity, its relations to CEDAW and the Commission on the Status of Women (CSW). Every stone was turned and results fed into the larger dialogue on a resolution on system-wide coherence. When the General Assembly met and unanimously adopted resolution 64/289, on July 2, 2010, many delegations hailed the historic creation of the new Entity saying it would put “women at the

the forefront of the international agenda as well as provide support for countries to strengthen national capacities towards women’s empowerment.” UN Secretary-General, Ban Ki-moon, praised Member States for taking this bold move, saying, “It will now be much more difficult to ignore women and girls—or fail to take the necessary action.”

The resolution stipulates that UN Women is to be governed by a multi-tiered intergovernmental governance structure with (a) ... the General Assembly, the Economic and Social Council and the Commission on the Status of Women, providing normative support functions and normative policy guidance to the Entity; and (b) ... the General Assembly, the Economic and Social Council and the Executive Board of the Entity governing its operational activities and providing operational policy guidance.

At its helm, would be an Executive Director/Under-Secretary-General. Former President of Chile, Ms. Michelle Bachelet, was the first Executive Director of UN Women. Upon taking office, Bachelet outlined five thematic priorities that she would concentrate on in her first 100 days, bearing in mind specific country contexts and capacities:

1. Expanding women’s voice, leadership and participation, working with partners to close the gaps in women’s leadership and participation in different sectors and to demonstrate the benefits of such leadership for society as a whole
2. Ending violence against women by enabling States to set up the mechanisms needed to formulate and enforce laws, policies and services that protect women and girls, promote the involvement of men and boys, and prevent violence
3. Strengthening implementation of the ‘women, peace and security’ agenda, through women’s full participation in conflict resolution and peace processes, gender-responsive early-warning, protection from sexual violence and redress for its survivors in accordance with UN resolutions
4. Enhancing women’s economic empowerment is particularly important in the context of global economic and environmental crises. UN Women will work with governments and multilateral partners to ensure the full realization of women’s economic security and rights, including to productive assets and full social protection
5. Making gender equality priorities central to national, local and sectoral planning and budgeting; working with partners, UN Women will support national capacities in evidence-based planning, budgeting and statistics.

She told the delegates to the first meeting of the UN Women Executive Board that she was “determined that UN Women will be a catalyst for change, offering new energy, drawing on long-standing ideas and values, and bringing together men and women from different countries, societies and communities in a shared endeavor. I want to underline that this endeavor will be a global one, though its impact will be experienced primarily at the country level; thus UN Women’s technical support and expertise will be available, on request, to all countries, developed and developing countries alike.”

As a Vice-President of the current Bureau of UN Women’s Executive Board, I have been able to witness UN Women’s evolution and impact, including in my country, Malawi. The 2013 Bureau is presided by H.E. Mr. Normans Penke, Permanent Representative of the Permanent Mission of Latvia, and has four Vice-Presidents—Mr. Vincent Herlihy, of the Permanent Mission of Ireland; Ms. Janet

Karim, of the Permanent Mission of Malawi; Mr. Roberto de Leon Huerta, (replaced by Ms. Elisa Diaz Gras) of the Permanent Mission of Mexico; and Mr. Junichi Sumi, of the Permanent Mission of Japan.

As UN Women became an active member of other organs of the UN with intergovernmental participation, it devised a “regional architecture” that would determine how and where it would deliver on its mandate. Malawi was in the plenary session of the 2012 annual session when the UN Women’s regional architecture was being discussed. At that time, Malawi was setting the stage for its tri-party elections in 2014. Malawi became the second country in Africa to have a female president in April 2012, following the death of former President, His Excellency the late Professor Bingu wa Mutharika. His death paved the way, through a constitutional provision, for Her Excellency Dr. Joyce Banda to become Malawi’s fourth President and the first woman to rule Malawi. At that time, Malawi was on track to attaining five of the eight Millennium Development Goals (MDGs) by 2015, but was behind and unlikely to achieve MDGs 3, 4 and 5 on promoting gender equality; combatting HIV/AIDS and malaria; and reducing child mortality. Malawi therefore made an urgent request during the 2012 annual session of the UN Women Executive Board for a UN Women country office to be established in Malawi.

UN Women agreed to establish a country office in Malawi, which, headed by Alice Harding Shackelford, has already vastly contributed to sustainable gender equality and economic empowerment. In its first year of operation alone, the Malawi UN Women offices have helped unlock progress for women in Malawi through efforts including 1. supporting the Ministry of Gender, Children and Social Welfare on the lobby and advocacy for the Gender Equality Act and developing the capacity of parliamentarians for the passing of the Gender Equality Act; 2. setting in place basket funding with donors and the UN to support the Malawian delegation to the 57th Session of the CSW and arranging preparatory and follow up programmes; 3. holding regular ongoing dialogues with women’s organizations and movements in Malawi to facilitate joint efforts and coordination within civil society on gender related issues, including the planning of a National Gender Forum to discuss the status of gender discourse and agree on common areas and indicators with Malawi’s Human Rights Commission and Ministry of Gender, Children and Social Welfare.

Many other exploits are being successfully led by UN Women teams around the world, making the Entity a sure game changer in global gender equality and women’s empowerment, and ensuring that the section of the world “holding up half the sky,” is fully recognized and acknowledged.

UN Women’s new Executive Director, Ms. Mlambo-Ngcuka of South Africa, has promised to continue this work, including through partnership with civil society, to ensure that women’s rights, empowerment and gender equality are central to the post-2015 development agenda, as outlined in UN Women’s paper on the stand-alone gender goal. UN Women has established Civil Society Advisory Groups (CSAGs) at global, regional and national levels and Mlambo-Ngcuka described her vision of “close and non-bureaucratic partnership in which the focus is on unity and solidarity for action.”

Forward with gender equality and women’s empowerment!

Photo:  
Janet Z. Karim.

Janet Zeenat Karim oversees Social Development and Humanitarian issues and is the Elections Officer at the Permanent Mission of the Republic of Malawi to the United Nations and she is also Vice President of UN Women.





# Sustainable Development that Leaves No One Behind

by Cristina Diez  
Representative to the UN, ATD Fourth World

Despite real progress in some regions concerning poverty eradication in the last years, 22% of people in developing countries are still living on less than \$1.25 a day and 43% are living with less than \$2.00 a day. Despite all the efforts made to eradicate poverty through the UN development agenda, including the MDGs, there is recent evidence that we are failing to reach the most vulnerable<sup>1</sup> who have been historically, and remain at present, most affected by both environmental degradation, and social and economic exclusion. Furthermore, many development policies and projects haven't had the desired impact and have contributed to isolating and displacing the most vulnerable populations.

"We have seen a whole family drowning in the water, and that water is mixed with the sewage. These families live under this pollution, they cook in that water; the children, their schools are flooded, the health centers are flooded, the markets are flooded, there is no way out, so the whole life in the neighborhood is threatened." (ATD Fourth World activist in Senegal, 2011)

In addition to being excluded from the benefits of the model of production and consumption that have a negative impact on the environment, people living in extreme poverty bear the burden of climate change. They work and live in the most degraded and dangerous conditions, exposed to air and water contamination,

landslides, floods and droughts, being forced to move from one place to another, with no security in terms of livelihood, work, health or education.

Still, they are not passive victims. They are on the front-line of action to deal with environmental crises, building their resistance with very few means, but with the knowledge and experience of those who have been living in hardship for generations. Unfortunately, this knowledge is rarely taken into account when it comes to addressing the challenges faced by society. The non-recognition as people who have something to contribute to society is probably the ultimate violence suffered by those who live in extreme poverty.

For two years ATD Fourth World has carried out a participatory research project with people living in extreme poverty in 12 countries, both in the North and South, to assess the impact of the Millennium Development Goals in their communities and to ensure that people living in extreme poverty can contribute their collective knowledge and experience to the sustainable development agenda that is being discussed at the UN.

"Even in extreme poverty, a person has ideas. If these ideas aren't recognized, people fall even deeper into poverty." (Participant in a regional seminar organized in the context of the participatory research in Ouagadougou)

From the collective knowledge gathered during the participatory research emanate five recommendations. They are a basis for dialogue with other stakeholders that are key actors in the discussions of this new development agenda.

The first recommendation: *Leave no one behind* reflects the ambition of people living in extreme poverty to help develop policies and programs that eliminate stigmatization and discrimination and that reach everyone, starting with the most difficult to reach: the weakest and most impoverished. For this to happen, the decision makers at local, national and international levels need to *introduce people living in poverty as a new partner in building knowledge on development*. This second recommendation requires recognizing that people living in poverty have valuable knowledge that can contribute to the construction of policy and development programs. The Guiding Principles on Extreme Poverty and Human Rights (A/HRC/21/39) provide a practical tool for policy-makers to guarantee that public policies (including poverty eradication efforts) reach the poorest members of society thereby ensuring their contribution. These recommendations need to be a crosscutting theme in all goals of the framework using appropriate targets and indicators.

Additionally, people living in extreme poverty have identified two main areas that the international community should prioritize and which constitute the third and fourth recommendations: *access to quality education and training for All* and *access to decent jobs and social protection*. The fifth recommendation: *promote participatory good governance* is based on the aspiration of people living in poverty to play an active role in a model of globalization that is based on human dignity. Transparency and accountability mechanisms at all levels of governance are crucial. Each of these three recommendations needs to be included in a self-standing goal in the new framework.



## Why Animals Matter in Achieving "The Future We Want"

At the World Society for the Protection of Animals (WSPA), we work towards the urgent international recognition of animal welfare as an essential element of sustainable development. Global adherence to animal welfare principles will have significant positive impacts on poverty eradication, food security, public health, climate change and the preservation of biodiversity.

Development professionals often overlook the reality that over 1 billion of the world's poorest people depend on animals for jobs, food, income, transport, social status and cultural identification. Good welfare practices improve animal survival, reduce costs and increase profits, and so enhance the productivity of the poor's only productive asset and contribute to eradicating poverty. Similarly, integrating animal welfare in disaster resilience and emergency planning prevents the unnecessary suffering of livestock and people and significantly enhances post-disaster recovery.

Livestock is crucial to food security. Unfortunately, our collective response to the growing demand for animal protein has been the expansion of industrial livestock production and farming practices, with many unintended consequences for:

1. Global food security, through the diversion of grains from people to livestock;
2. Greenhouse gas emissions, through the conversion of forests and grass lands into arable land for livestock feed production;
3. The welfare of billions of animals.

Moreover, the growth in industrial livestock production looks set to increase the occurrence and global costs of zoonotic diseases, as demonstrated by the examples of avian and swine flu.

Sustainable livestock production that comprises animal welfare principles offers an alternate and already proven approach to achieving the desired objectives of food security, social stability and environmental sustainability as well as promoting equitable economic growth.

The impact that a greater focus on animal welfare could have on sustainable development is considerable and must be acknowledged in the global post-2015 development agenda.

Photo 1011821 © WSPA/Kate Holt  
Taken in Kenya in during the severe drought in 2011. This boy had brought his animals to a man-made watering hole near Mwingi in Eastern Kenya. WSPA was on the ground to provide food and medical care for livestock affected by the drought.

Message provided by the World Society for the Protection of Animals.

[www.wspa-international.org](http://www.wspa-international.org)

[1] [www.un.org/millennium-goals/11\\_MDG%20Report\\_EN.pdf](http://www.un.org/millennium-goals/11_MDG%20Report_EN.pdf)  
[cristina.diez@atd-fourthworld.org](mailto:cristina.diez@atd-fourthworld.org)

[www.atd-fourthworld.org](http://www.atd-fourthworld.org)  
[www.atd-fourthworld.org/Towards-Sustainable-Development.html](http://www.atd-fourthworld.org/Towards-Sustainable-Development.html)





# A DAY IN THE WORLD

**Bangladesh, 09:54.**

*Bangladeshi workers dry leather hides on the banks of the River Buriganga. "About 90 percent of the workers at the Hazaribag tannery die before they reach the age of 50, due to the toxic environment. Some 58 percent suffer from ulcers, 31 percent have skin diseases, 12 percent have high blood pressure, and 11 percent suffer from rheumatic fever." Untreated runoff from the tannery is a major source of river pollution.*

*Photo: A. M. Ahad*

[www.aday.org](http://www.aday.org)  
© Max Ström



# Holistic Thinking At Work:

## *The Sustainability Laboratory and Project Wadi Attir*

An Interview with Dr. Michael Ben-Eli,  
Founder of The Sustainability Laboratory



### **What inspired you to create The Sustainability Laboratory?**

If you use the term sustainability, as it should be used, in the context of the whole planet, the integrity and health of its ecosystems and the enduring well-being of humanity, then the current trajectory of human affairs is evidently unsustainable. Many key components of the biosphere, as well as critical social and economic indicators, show deep signs of stress. In spite of growing awareness, the issues are relentless and unyielding and most existing mainstream economic and political entities are not evolving fast enough to meet the challenge. The list of issues is long. It includes Ozone depletion, climate change, loss of biodiversity and forest cover, the pressure on potable water resources, the loss of fertile soils, and more. It also includes a persistent, endemic failure of our social and economic institutions to address these issues effectively and in a timely manner. Working with multilateral organizations and the private sector on sustainable development-related projects, I became increasingly concerned about the huge gap between the rhetoric of sustainability and the actual progress on the ground. I began to study and later understand the limitation inherent to most of our large, existing institutions that are often, and rightly so, perhaps, risk averse. Their very structure rarely encourages breaking away from the prevailing frames of reference. The problem is that the issues facing us today are unprecedented in scope. These require a deep transformation in the ways we do things, in our view of the world and the values we hold dear. There is no textbook to guide us.

Only bold experimentation with new criteria, approaches and methods might help. Most institutional settings don't allow the freedom to experiment. I thought that an independent, agile entity free from similar structural limitations, and with the deliberate mandate to experiment, would be an interesting initiative—hence the idea of The Sustainability Laboratory. It was set up in order to develop and demonstrate breakthrough approaches to sustainability practices, expanding prospects and producing life-affirming impacts on people and eco-systems, in all parts of the world.

As a youngster, I was fortunate to study and work with great teachers. People like Buckminster Fuller, Gordon Pask and Stafford Beer, who were ahead of their time. Over the years I was able to synthesize what I learned from them into a potent framework that provides the conceptual basis for the work of The Lab. This framework integrates a rigorous definition of sustainability with a derived set of five core sustainability principles that are expressed in relation to five essential domains: The Material Domain; The Economic Domain; The Domain of Life; The Social Domain; and The Spiritual, or Values Domain. There are many valuable projects today, related to the sustainability agenda, but most focus on one specific issue, alternative energy, or water, for example. To make a real difference, however, the five domains and the related principles have to be integrated into a coherent whole. The Lab's design for Project Wadi Attir, demonstrates such a comprehensive integration.

### **How did you begin working with the Bedouin community and did you have a role model for Project Wadi Attir?**

A few years ago, as I was contemplating the idea of The Lab, I had the chance to visit "Las Gaviotas," a wonderful development project in Northeast Colombia. The area, basically savannah land with hard grass, had resisted all sorts of cultivation. Paulo Lugari, a Colombian architect, had the idea of developing a rainforest there. It sounded absurd 25 years ago when he started, but he persisted and now the area supports a vast, full-grown rainforest where they've introduced plants with economic value that support the local economy in what is a very violent and impoverished region. Lugari is a profound system thinker and Las Gaviotas demonstrates a true holistic approach to development. I was inspired, and when the opportunity of doing something in the Negev emerged, I thought about "Gaviotas" in the desert. The opportunity came when I had the chance to visit the Blaustein Institutes for Desert Research, of the Ben Gurion University of the Negev, along with my colleague, Joshua Arnow. The place is a hotbed for world-class research in advanced technologies related to living in arid zones. During that trip I was exposed to the untenable conditions of the Bedouin community particularly in the so-called unrecognized villages. It did not seem right that full citizens in a country like Israel would live in desperate circumstances when there were such incredible technologies being developed nearby. I felt there was an opportunity to help. The Arnow family has been active with philanthropic support in the Bedouin community, so thinking about the possibility of a project there was natural. I sketched out a concept of what such an initiative could be—most who were exposed to it thought it was far-fetched—and with Joshua's encouragement and support, returned to the Negev to better assess possibilities. During that reconnaissance trip, I was introduced to Dr. Mohammed Alnabari, Mayor of Hura, a local Bedouin township of some 15,000 people. Mohammed represents a youthful, new, farsighted leadership in the Bedouin community. We hit it off immediately and decided to collaborate on a model project, which will showcase the integration of many development issues in one microcosm. The rest is now history.

### **What concretely does Project Wadi Attir aim to achieve?**

The underlying purpose is to develop a model for sustainable agriculture in an arid zone, demonstrating a holistic application of the Lab's sustainability principles in an initiative that would benefit the local community and could be applied in other parts of the region, as well as in similar arid areas in other parts of the world. The project is designed to leverage Bedouin traditional values, experience and aspirations with modern day science and cutting-edge green technologies. In the farm, we shall be growing a mixed herd of goats and sheep organically for the production of a range of dairy products including Bedouin types of cheeses that don't require refrigeration. We shall also cultivate desert medicinal plants that Bedouins have been using as their healthcare system. This is all knowledge that is disappearing very quickly and that isn't completely known to science yet. We are working with a local Sheikh who has devoted his life to studying these wild plants and we have started the process of domesticating them and developing a line of health-related products for sale. We are also developing a women-led program to reintroduce nutritious, indigenous vegetables to common use in household gardens. Last, but not least, the project will house a visitors, training and education center that will promote eco-tourism, support outlying villages with technical training, and function as an important regional education facility. An integrated technology infrastructure will support the whole site, converting

waste into useful resources and reducing harmful emissions. This system includes advanced soil enhancement technology, solar energy and bio-gas production, the production of compost from organic waste, advanced irrigation management, and wastewater treatment and recycling.

On the social front, the focus has been on community participation and on encouraging the emergence of a group of entrepreneurs who will own their own businesses and be responsible for their own future. We felt that the project should not be associated with one particular tribe, but rather be open to people from all Bedouin towns and villages. We adopted a cooperative structure and we also encouraged women's full participation from the outset. It is rare to see combined teams of men and women working together in this community, and we hope that the Wadi Attir experience will inspire others.

### **What are your next steps?**

Project Wadi Attir has been very time-consuming and implementing it correctly and fully will still pose several challenges. Ultimately, we envision the project as a learning center on many levels. While we introduced various new concepts to the group involved with the project, the Bedouin community has much to teach. An attitude towards plants, for example, that is different from the perspective of large-scale agro-industry. In the case of medicinal plants, such plants are viewed like personal friends that have to be treated in that way. This is an orientation we have to restore in our lives and which was typical to most Indigenous Peoples. The practice of hunters asking forgiveness from prey is different from the brutal ways we raise animals industrially. We need to learn from a community that was adapted to life in a harsh environment and that lived a life closely aware of the carrying capacity of this environment. They have a deep understanding of dependencies and interdependencies that escapes people in modern life. Today their well-adapted system is being destroyed but in its very essence it has many valuable lessons to teach. As for The Lab, we have some ambitious plans for the future; we need to consolidate our experience of the last five years and move forward to a whole new level. In the process, we are developing a graduate level certificate program—The Lab's Global Sustainability Fellows Program—in collaboration with 12 universities from around the world, to allow students in different disciplines to gain intensive exposure to issues of sustainability. We are working on developing a global network of R&D centers that map onto specific eco-zones, and look forward to launching model projects in different ecologies. Long term, we would like to see The Lab emerge as a preeminent global resource for advancing a peaceful transition of world society, its economy and its institutions to a sustainable basis.

*Opposite page: Ali Alhawashleh, member of the project team, preparing health products from traditional medicinal plants.*



*This page: Founders of the Wadi Attir Association. Top row: Hani Ghadir; Fahed Alasibi; Ibrahim Alatrash; Ali Abu Ikean; Aattef Abu Ajaj; Naifa Alnabari; Dr. Michael Ben-Eli; Yones Nabari. Front row: Mohammed (Shahdeh) Abu Sbeit; Dr. Mohammed Alnabari; Ali Alhawashleh; Mariam Abu Rakayek. Photos by Wolfgang Motzfi-Haller.*

[www.sustainabilitylabs.org](http://www.sustainabilitylabs.org)



# Art as a Path

An Interview with Mariko Mori



*Rebirth: Recent Work by Mariko Mori* on view at the Japan Society Gallery from October 11, 2013 through January 12, 2014, showcasing 35 immersive installations, sculptures, drawings, photographs and videos produced by the artist between 2003 and 2012. Mori's first major museum show in the US in 10 years, this exhibition presents her artistic evolution during the last decade, her statement of rebirth in an age of endangered environment and a lost connection between man and nature.

www.japansociety.org  
www.Faoufoundation.org

**What inspired you to create your exhibit on Rebirth?**

The concept of rebirth was present in every ancient culture. It's a rule of nature. We are nature, so it also applies to us and to the universe as a whole. It could be a very important message for today.

**Your work references science as well as spirituality. How do you reconcile these diverse aspects? Have you engaged the scientific community? Do you have a spiritual practice that accompanies your artistic process?**

The process of making artwork is a path for me. Many different experiences collaborating with people, researching, and visiting different places in the world guided my understanding of life and opened me to various philosophies. I follow the path and the opportunities that present themselves along the way. For *Tom Na H-iu*, I collaborated with the Nobel Prize-winning professor who detected Supernova Neutrino in 1987. *Tom Na H-iu* is connected to an observatory at the University of Tokyo's Institute for Cosmic Ray Research. When they capture neutrino, it's sent to my work via network, and the work changes color accordingly. When I wanted to produce a work related to Buddhist philosophy I actually devoted time to research, meditate and study to try to achieve the state of mind that was needed for the artwork. I then dedicated one year to produce the work itself. It was 1996 and I was quite

young, so maybe I was also quite naïve, but I tried my best to experience that state of being, in order to express it. That piece was a 3-D video called *Nirvana*.

**Many of your pieces have names like, Nirvana, Oneness, Rebirth. Is it ever intimidating to create artwork with such titles?**

Usually, the title comes at the very end. Before I decide on the title, it's like an abstract object, so I have to communicate with the public to provide some kind of guidance. It could be sort of ambitious, but words don't describe everything. When you say "pure land," "nirvana," or "oneness," the words exist, but they don't really explain what they represent. Through artwork people can have their own experience. So, it's more about transcending language; the title is like a channel to experience the work.

**Is there an overarching message you want to convey?**

I want to promote the consciousness that we are residents on Earth. We used to be more deeply rooted in nature. Today that connection is remote, but we are also nature and we need to remember that. I formed a foundation called FAOU to install site-specific permanent installations on each continent that honor nature and promote local culture. Art can link to all sorts of disciplines from ecology, to culture, eco-housing, ecotourism, green energy, agriculture, science.... The first installation consists of a Sun Pillar and Moon Stone paying tribute to the history of our universe and solar system. During the winter solstice time, the sun goes down and casts shadow onto the Moon Stone, reminding us of the cycle of nature. Our goal is to transcend national borders with the installations. It was created on Miyako Island, an Okinawa island, which is part of Japan, but is actually closer to Taiwan and China. The island has a pristine, almost original state of nature, which has been very well preserved by the local people, along with their spiritual traditions. There are 50,000 inhabitants and 500 sacred sites where local priestesses continue to perform ceremonies dating back to the 13<sup>th</sup> century. It's very important to have a good relationship with the local community. We need their support, and must learn from them. In turn, the work is also a gift to them, which should help to sustain their culture; so there is a true collaboration.

**Where do you plan to create the next installation?**

The second one is envisaged as a rainbow waterfall, to be installed in Visconde de Mauá, Brazil, located between São Paulo and Rio de Janeiro, in time for the Olympics. Depending upon the sun, the color will change from blue to gold. The site we hope for had been deforested for farming purposes, and has now been reforested thanks to the efforts of one couple that devoted themselves to replanting all the trees; so the local community there is already ecologically sensitive. We hope that when people come to enjoy the Olympics they are also reminded to connect with nature.

**Your work has changed at different periods in your life. Looking back on your trajectory, what motivated your creative journey?**

My first connection to art and the freedom to create happened in preschool. As an adult, when I first visited London and experienced installation art, it was a showcase for freedom of expression and the ability to use any medium—not just painting, sculpture, or other traditional forms. There is total freedom to create anything you would like to create, however you want. It could be for yourself, for the community, for nature, or for the world. There's no limitation to communicating with anything. Art is an essential act for human beings to be joyful. There is something within its realm that we can do.

Left:  
Mori, Mariko (b. 1967) © ARS, NY  
*Tom Na H-iu 1* (3.5 meters), 2006.  
Glass, stainless steel, LED, Real time control system. 327.4 x 115.3 x 39.6 cm. Edition of 2 + 1 AP.  
Courtesy of Shiraishi Contemporary Art, Inc., Tokyo, Deitch Projects, New York. Photo credit: Richard Learoyd. © artwork, Mariko Mori 2009 © photograph, Richard Learoyd. All Rights Reserved. Photo courtesy of Mariko Mori / Art Resource, NY.

Right:  
Mori, Mariko (b. 1967) © ARS, NY  
*Esoteric Cosmos (Pure Land)*. 1996-1998. Glass with photo interlayer, overall: 120 x 240 x 7/8 in. (304.8 x 609.6 x 2.22 cm). Gift of William J. Bell in honor of the museum's 40<sup>th</sup> anniversary (M.2005.136.4a-e). Location: Los Angeles County Museum of Art, Los Angeles, California, U.S. Digital Image © Museum Associates/LACMA. Licensed by Art Resource, NY.



# Documenting Change in Antarctica

*An Interview with Andrea Juan*



*Andrea Juan, El Bosque Invisible  
Antártida 2323*



### **What inspired your work in Antarctica?**

I was fascinated by glaciers. In Argentina there are many, especially in Patagonia. I began to learn about how the glaciers there, as in the rest of the world, were reducing in number and in size very rapidly. It seemed like a warning sign, a sort of poetry, as though a light were being turned off. It was a situation of sadness, as well as a visually aesthetic matter. I always took it as something poetic and wanted to work with that poetry from a visual standpoint. I started with the glaciers in Patagonia and then moved on to Antarctica.



### **How did your collaboration with the scientists develop?**

I began studying the retraction in Patagonia in the year 2000 and I became aware of the scientific projects that were being realized. When I came into contact with the National Director of the Antarctic in 2004, Dr. Mariano Memolli, he opened up the possibility of dialoguing with the scientists of the Antarctic Institute and working with their research projects. I contacted the geologist Rodolfo del Valle and the engineer Pedro Skvarca. They were studying the changes in the climate of the Antarctic peninsula and how those climatic changes were influencing the loss of the ice mass and changing the visual structure of the peninsula. With the loss of an enormous ice shelf that went into the sea, the methane gas that was covered for centuries entered the atmosphere and traces of methane appeared on the coast. It's a slow glaciological phase that is happening now in a very abrupt manner. After working with the scientists, I felt that their investigations enriched my projects in such a way that I would feel empty if I didn't work with that scientific ingredient. At the beginning it's strange to involve them because they have a fact-based relationship to circumstances, whereas my representation is poetic, metaphorical. The scientists were always concerned about people understanding that this is not exactly how things are in reality, but the spectator doesn't have that doubt. Everyone understands that there is a poetic license in developing

### **¿Qué inspiró tu trabajo en Antártida?**

Quedé muy fascinada por los hielos. En Argentina hay varios glaciares, sobre todo en la parte de Patagonia. Empecé a enterarme que los glaciares allí, como en el resto del mundo, se estaban reduciendo en cantidad y en tamaño de una manera muy rápida. Me pareció que era un llamado de alerta, una especie de poesía, como si se apagaba una luz. Era una situación de tristeza y también una cuestión visualmente estética. Siempre lo tomé como algo poético y quería trabajar con esa poesía desde lo visual. Así empecé con los glaciares de Patagonia y luego pasé a Antártida.

### **¿Cómo desarrollaste la colaboración con los científicos?**

Comencé a estudiar la retracción en Patagonia en el 2000, y me fui interiorizando poco a poco con los proyectos científicos que estaban llevándose a cabo. Cuando me relacioné con la Dirección Nacional del Antártico en el 2004, el Director Nacional, el doctor Mariano Memolli, me abrió la posibilidad de dialogar con los científicos del Instituto Antártico y de trabajar con sus proyectos de investigación. Me puse en contacto con el geólogo Rodolfo del Valle, y el ingeniero Pedro Skvarca. Los dos estaban estudiando los cambios que sucedieron en el clima de la península antártica y como esos cambios climáticos influyeron en la pérdida de masas de hielo y cambiaron la estructura visual de la península. Con la pérdida de una barrera de hielo de un tamaño enorme que se fue al mar, el gas metano que estaba tapado durante siglos empieza a salir al aire y aparecen partículas en la costa. Se trata de una etapa glaciológica lenta que está sucediendo ahora de una manera abrupta.

Después de trabajar con los científicos, no pude desvincularme de sus investigaciones; enriquece el proyecto de una manera tal que me siento vacía si no trabajo con ese ingrediente científico. Al principio implicarles es extraño porque ellos tienen una relación fáctica con los hechos y mi representación es poética, con metáforas. Los científicos siempre se preocupan que no quede duda que esto no es así...pero el espectador no tiene esa duda, todos entienden que no es una cuestión fáctica de como el color esta puesto, que hay cierta licencia poética para desarrollar el proyecto. Aparece algo nuevo que interactúa ciencia y arte donde el espectador se siente interesado en poder transitar una obra que tiene poesía pero a su vez tiene ciencia.

### **¿Has encontrado algunas sorpresas?**

Cuando fui a Antártida en 2005, pensaba que el proyecto iba a durar un año, pero quedé atrapada con el tema. En ese momento, la Barrera de Hielo Larsen se había perdido hacia pocos años y no se sabía que habían nuevas especies...ahora sí lo saben. Las especies estaban, pero el hombre no las conocía. Es muy alentador saber que hay siempre algo más allá del conocimiento humano.

Los proyectos científicos duran muchos años; los resultados no se ven instantáneamente como en un proyecto artístico. Hay un proceso de tomar y bajar los datos, estudiarlos y ver como resultan al año siguiente. Otro proyecto interesante para mí que desarrollé en 2010 tenía que ver con el "bosque invisible," basado en el fitoplancton marino en el fondo del mar que absorbe anhídrido carbónico y exhala oxígeno al aire, modificando el clima de la tierra. Es muy similar a lo que genera un bosque en cualquier parte del mundo pero es invisible a los ojos humanos. Científicos de todas partes del mundo trataron de mantener y aumentar el bosque, colocando

the project. Something new appears that blends science and art and the spectator is able to traverse a work that has poetry, but also contains science.

### **Have you encountered any surprises?**

When I went to Antarctica in 2005 I thought the project would last one year, but I became glued to the theme. At the time, the Larsen Ice Shelf had been lost for only a few years and it was not yet known that there were new species. The species existed but man did not know them. It's very encouraging to know there is always something beyond human knowledge. Scientific projects last many years; the results don't appear instantly as with an artistic project. There is a process of taking data, studying it, and analyzing results the following year. Another interesting project for me that I developed in 2010 had to do with the "invisible forest," based on marine phytoplankton at the bottom of the sea that absorbs carbon dioxide and exhales oxygen to the air, modifying the climate of the Earth. It is very similar to what a forest generates in any part of the world but it is invisible to human eyes. Scientists from around the world tried to maintain and augment the forest, placing particles of iron to generate more phytoplankton, but it didn't work, so this project was discarded and the forest was maintained as it was.... I hadn't expected to encounter such significant changes in such a short period of time.

partículas de hierro para generar mayor cantidad de fitoplancton, pero no funcionó, entonces se descartó ese proyecto y se mantuvo los bosques como estaban.... No esperaba encontrar cambios tan significantes en tan poco tiempo.

### **¿Cómo ha evolucionado tu perspectiva?**

Al principio los proyectos se basaban en las situaciones de cambio, como una especie de denuncia o reflexión respecto a los cambios climáticos que se estaban dando. Con los años, empiezan a aparecer otras situaciones positivas que me motivan a buscar soluciones a los problemas, como las nuevas especies que se descubrieron con la desaparición de las barreras de hielo. Fue negativo perder los glaciares de agua dulce, pero después aparecen nuevas especies debajo de ellas. Empieza una nueva vida. No es negar eso que sucede, sino empezar a pensar una situación positiva y no catastrófica al planteo. La barrera de hielo ya está perdida, ya modificó la salinidad de los océanos.

¿Qué hacemos ahora en función de eso? ¿Qué podemos trabajar juntos para el futuro? El ser humano es una pequeña partícula en un espacio gigante, pero es fundamental ser consciente de lo que el hombre genera y de como modifica el medio donde vive. Puede contribuir a vivir en un medio mucho mas sano y cuidado, con energía renovable, puede cambiar la manera en que se vive. Ahora me resulta muy difícil trabajar dentro de un estudio. Prefiero plantear situaciones en espacios abiertos, trabajar con el viento, el clima, lo que aparece dado por la





### How has your perspective evolved?

Initially the projects were based in situations of change, as a kind of denunciation or reflection on the climatic changes that were occurring. Over the years, other positive situations began to appear that motivated me to seek out solutions to the problems, such as the new species that were discovered with the disappearance of the ice shelves. It was negative to lose the fresh water glaciers, but new species then appeared underneath them and new life began. It's not about denying what is happening, but rather about formulating a positive instead of a catastrophic situation. The ice shelf is already lost; it already modified the salinity of the oceans. What do we do now? What can we work on for the future? Humans are a tiny particle in a gigantic space, but it is crucial to be conscious of what humans generate and how we modify the environment in which we live. We can contribute to living in a much more healthy environment. With renewable energy, we can change the way we live. It has now become very difficult for me to work in a studio. I prefer to create situations in open spaces, working with the wind, the climate, what is given by nature. I only use elements that don't modify the environment; I introduce elements of contrast to obtain images of a strong saturation of color, but once the work is completed the space is exactly as I found it. Working in the environment, in open spaces, is not like working in a studio where you can create the conditions of light and contrast... sometimes I have to wait for magic to appear in the space. If there is no magic, the fundamental is missing.

### Do you believe the project can have an impact in the political, economic, or social realms?

Antarctica is a space of peace, according to the international treaty, and functions as a global laboratory. As a virgin territory, the development of investigations can be measured more easily. The artistic project helps the scientific research gain greater outreach. When the project began to be known, it was well received and multiplied. Thereafter we were able to incorporate artists from different countries, who reread the space in their own way as each artist works with a different aesthetic and technique. The network of artists worldwide is now quite large and we stay in touch through traveling exhibits, conferences and festivals.... We also initiated polar dialogues to incorporate the Arctic and we developed educational programs for primary and secondary schools.

Art helps us understand situations that can seem distant from daily reality. When one reads statistics, they are numbers; they provide more exact and truthful information, but also a colder approach to an issue. With images, the sensitivity begins to flow in a different manner, the work transcends reason, enters the soul, and that's where change happens.



naturaleza. Trabajo solamente con elementos que no modifiquen al medio; llevo elementos de contraste para tener imágenes que sean de una saturación fuerte de color, pero una vez que yo termino el trabajo, el espacio queda tal cual como estaba. Cuando trabajas en el medio, en espacios abiertos, no es como en un estudio donde puedes crear las condiciones de luz y contraste, a veces tengo que esperar que aparezca cierta magia en el espacio. Si no hay magia, falta lo fundamental.

### ¿Crees que el proyecto puede tener un impacto a nivel político, económico o social?

Antártida es un espacio de paz según el tratado internacional y funciona como un laboratorio mundial. Al ser un territorio virgen, se pueden medir más fácilmente los desarrollos de ciertas investigaciones. El proyecto artístico hace que la divulgación científica tenga mayor alcance. Cuando el proyecto se empezó a divulgar, fue bien recibido y se multiplicó. Luego tuvimos la posibilidad de incorporar a otros artistas de diferentes países, haciendo una relectura del espacio ya que cada artista le pone una estética y trabaja con técnicas diferentes. La red de artistas de todas partes del mundo ahora es muy grande, y seguimos en contacto a través de muestras itinerantes, conferencias, festivales.... También iniciamos diálogos polares para incorporar el Ártico y desarrollamos programas educativos para escuelas primarias y secundarias.

El arte ayuda a ver situaciones que pueden parecer ajenas a la realidad cotidiana. Cuando uno lee datos de estadísticas, son números, dan una noción más exacta y verídica, pero más fría. Con imágenes, la sensibilidad empieza a fluir de una manera diferente, la obra trasciende a la razón, entra en el alma y es allí que se modifica algo.



## Streaming Museum

Streaming Museum is bringing the arts to millions of people around the world via the technology and Internet platforms that are interconnecting cultures and enabling the dramatic changes taking place in the world today.

Mobile devices and urban screens that millions pass by each day are vehicles for presenting image and sound that, acting as “contemporary hieroglyphs,” communicate across linguistic and cultural boundaries.

Nina Colosi, Founder of Streaming Museum, launched its inaugural exhibition simultaneously on screens in public spaces on seven continents and at StreamingMuseum.org on January 29, 2008, at the cusp of the global expansion of urban screens, Internet and mobile devices.

Since then, the museum has produced and presented an ongoing program of exhibitions that have been viewed at over 60 public space locations worldwide and on its website, as well as a variety of programming at cultural, educational and corporate centers.

Streaming Museum is part of the information-with-social-value economy. A contemporary worldview and the universal commonalities and diversities among cultures are reflected in

its program of international visual and performing fine arts and popular culture, innovation and visionary ideas across fields.

In collaboration with World Council of Peoples for the United Nations and international partners, A View From The Cloud, a globally touring exhibition and public program series opening 2014, will provide an inspiring experiential connection to sustainability. It will convene innovative thinkers from the arts and diverse disciplines with those engaged in sustainable development advocacy, policy-making, urban planning and practical solutions.

*Photo: Video still from Björk's "Mutual Core" in Times Square as the March 2013 "Midnight Moment," by Ka-Man Tse @TSq Arts. The project was launched in collaboration with Streaming Museum, Times Square Arts, Times Square Advertising Coalition and MOCAtv Museum of Contemporary Art Los Angeles. The video, by Andrew Thomas Huang, was part of Streaming Museum's Nordic Outbreak exhibition that toured partnering screens in Africa, Antarctica, Asia, Australia, Europe, and South America.*

For current and past exhibitions, news and information on artists, public programs, and partnering locations, go to [www.streamingmuseum.org](http://www.streamingmuseum.org)





## Perspectives on Policy:

*A Conversation with European Commissioner for Sustainable Development, Andris Piebalgs*

**As we're meeting shortly before the presentation of the High Level Panel Report on the post-2015 development agenda, could you share your own vision and expectations?**

Personally, I believe we have to design a framework that both ensures each person has the freedom to live his life in decent conditions and enables future generations to thrive. Freedom is the key. It requires money, food, water, health, and access to education. Today, children are being deprived of a chance in life for no fault of their own. As a European politician, the point of departure is considering that the eradication of poverty is the task of mankind and that we have the means to achieve it.

**Speaking of freedom, could you address the topic of migration? The Office of the High Commissioner for Human Rights has drawn attention to the risks of integrating European migration policy**

**into the security, defense and criminality framework, rather than fostering a human rights-based approach.**

Being Latvian, I think of Europe as a place of migration. I still remember that when Latvia's accession was being discussed, there was fear that the freedom of movement of Poles, Latvians, or Lithuanians, would destroy the European Union. Later on, when we joined and Latvians were seeking jobs in the UK, the tabloids were fear-mongering saying, "Latvians (or Poles) are preparing to invade Britain." Even within Latvia, moving from a small town to Riga, despite sharing the same nationality and language, it wasn't easy to be accepted by new neighbors. Migration is always a challenging process and it's easy to point to isolated incidents of violence, which politicians tend to use to advance their own interests, but I believe Europe is actually a success model. Governments should do everything possible to integrate people. People should also

try to integrate in their own way and not expect that it will happen automatically. At the end of the day, if you speak the language of the country and have respect for its values, your cultural background and language will also be respected. In the European Parliament, everybody speaks English or French, but we maintain linguistic diversity as a reminder of the importance of respecting cultural identity. Many of us are descendants of migrants. The crucial area to invest in is education. When each child has a decent education, we will pave the way for more harmonious societies and more successful integration and migration policies.

**The topic of education leads to questions of employment. Has high unemployment in Europe impacted public support for aid outside of Europe?**

Four countries in Europe have surpassed the 0.7% target for Official Development Assistance (ODA). The EU as a whole is at 0.43% and, at this stage, we would like to be at more than 0.5%. But globally Europe is giving more than 56% of ODA. It's difficult to argue for development cooperation in countries facing 25% unemployment and large cuts in the public sector, but Europe has managed to make the case reasonably well by building on the principle of solidarity. The majority of Europeans want to support development in poorer nations and understand that there are parts of the world that are definitely worse off. In Latvia, when people saw pictures of the hospitals being built in Burkina Faso with their support, they felt positively towards those initiatives. In addition to the moral dimension, there is also a pragmatic side. It is less costly to help a country become prosperous than to cope with the effects of political and military instability. Of course, money alone does not buy peace. Political solutions are necessary.

**Coming from a country that has experienced a massive political transition and having advocated for Latvia's right to self-determination, how do you believe the EU should respond to current aspirations for self-determination, such as as those in Spain, and help resolve longstanding conflicts in the European context, as in the case of Cyprus, for example?**

The decisions that impact people's lives most directly are those that happen in municipalities. Furthermore, people care about their roots, and roots are very much related to culture and language. Europe comprises so many languages and cultures. It's necessary to try to find satisfaction through existing political schemes as a starting point. Political leaders have a responsibility to represent people's will and to strike necessary compromises so that people feel that their voices are being heard. It will be a permanently evolving process, but Europe can't sort out the individual cases of each community. We also need to recognize the difficulty of promoting ideas at a European level when most influential voices and media outlets are very much nationally based. The European Union is a fantastic construction because it has been created in a peaceful way, following democratic procedures. Ultimately, constitutions can be changed, democracy can't be. With regard to unresolved issues, like the case of Cyprus, the whole island actually is part of the European Union. That's already clear. But the conditions of reunification can't be forced. Much effort was placed in the development of a UN plan. Unfortunately, it was rejected. How many years it will take to come to a solution, I don't know. Political processes are delicate. Thinking back to my own country's border issues with Russia, negotiations were arduous and the matter was very polarizing at the time. However, today, for many Latvians, it is a distant memory. We need patience.

**How can multilateral organizations promote the implementation of rights that may not be supported by the majority of a population?**

I am optimistic. No leader would say that human rights are not important, because human rights imply access to water, food, education, and health. A global definition of human rights is essential and the UN is the only organization that embraces all nations. Concrete actions are necessary. The Millennium Development Goals (MDG) framework was created to deal with poverty and, even though it was imperfect, it did have positive effects in terms of life expectancy, or women's rights, for example. People do need to be able to hold governments accountable, and the UN can help. It's not normal that in times when people are extremely rich, so many have insufficient nutrition. We shouldn't rely on charity organizations and donors. We need to establish systems that are honest with people and examine what would be fair tax rates. There is no 'silver bullet.' Very painful circumstances persist, but I believe the world has become a better place.

**What role do you attribute to civil society?**

Sometimes I sense that civil society in Western countries is weaker now than it was 10 or 50 years ago, and I don't know how to explain this phenomenon. Governments are never completely happy about engaging civil society or media, but civil society is crucial for any democratic and healthy country. You can't create civil society. However, at the European level, we do provide support for civil society organizations to enable the expression of different ideas and also to help deliver services in areas where it is challenging to work with a government directly. Civil society is also critical when it comes to encouraging popular support for initiatives from a moral point of view. Especially in the area of sustainable development and development cooperation, I can provide rational arguments, but the technical and pragmatic aspects are not enough, there has to be a heart behind them as well.

*Photo on opposite page: Commissioner Piebalgs at a meeting of the High-Level Panel on the Post-2015 Development Agenda. This page: Commissioner Piebalgs with UNDP Administrator, Helen Clark. Photos courtesy of the European Union External Action Service.*

[www.ec.europa.eu/commission\\_2010-2014/piebalgs/](http://www.ec.europa.eu/commission_2010-2014/piebalgs/)





# The Blue Frog Society: A Habitat Without Territory

by Barbara Holub



**Issue # 2:**  
**Reassess vital issues like sustainability**

**Reassess vital issues like sustainability. Reassess vital issues. Avoid empty phrases. Sustainability has become an empty word, a synonym for emptiness. How can it be filled with new meaning?**

**Election periods and the need for immediate success prevent long term thinking. Reassess vital issues like sustainability. Ask questions transgressing your imagination. What do you expect from an artist? What do you expect from yourself? Can an artist contribute to sustainability? Yes we can.**

**But we need you to come along.**



## The Blue Frog Society

The Blue Frog Society was founded in 2010, in a small jungle-like wood, on the border of the largest new urban development of Vienna in the next 30 years, the future Aspern Lake City. This piece of land seemed to be exempted from investors' interests, a messenger of a future society—of a new species proclaiming new values of society and cohabitation. The Blue Frog Society published their "10 issues" discretely hidden in "found, set, appropriated,"<sup>1</sup> in 2010, and then presented them publicly for the first time at the exhibition "The Future of the Future" at DOX Center for Contemporary Art, Prague, 2011.

## New Values, New Commons

The Blue Frog Society employs artistic strategies to investigate issues of territory and habitat that go to the very foundation of the dominant socio-economic system. It pushes the borders of the "possible" to make space for the unplanned and unthinkable, emphasizing civic engagement and the need for common public space, linking the art context to society.

This project also takes on a new understanding of "participation" and "commons," developing an open-ended process of acting, referring to the current political dimension of new forms of commons, as Michael Hardt describes them: "politics involve the production of the commons (not only the distribution), i.e. the production and reproduction of social relations and forms of life."<sup>2</sup> Jacques Rancière defines the relation between politics and aesthetics as a conceptual problem: artistic practices are possibilities of doing and acting, referring to the French notion of "le partage" which involves partaking and sharing, both contributing to "common wealth."<sup>3</sup>

Therefore the BFS offers "shares" of the non-territorial habitat as a new form of collecting art by becoming part of a collective art project.

## A Habitat Without Territory

The Blue Frog Society claims a new habitat—a habitat without territory—transgressing borders, especially in the context of a new "walled Europe," not just as an idea, but as an active engagement in society.

Presented for the first time in New York at "Windows on Madison"/Czech Mission to the UN,<sup>4</sup> then at the 64<sup>th</sup> Annual UN DPI/NGO conference,<sup>5</sup> The Blue Frog Society invited the participants of the conference to contribute their ideas, desires, expertise from various angles and backgrounds, as well as their critical input for building this community and discussing the future of a habitat without territory.

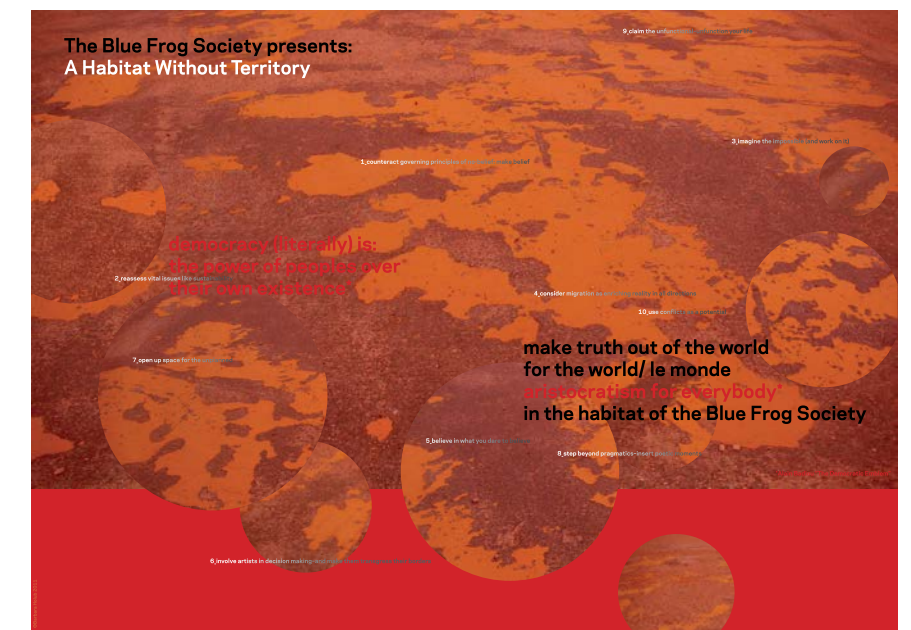

Photo on opposite Page:  
New Year's Concert of the Blue Frog Society at the new urban development of Vienna - Aspern Lake City, Jan.13, 2013, with contributions by Folke Köbberling, Martin Krenn, Isa Rosenberger, Rita Vitorelli, Joanna Warsza.

Photos on this page, Top:  
Site where the Blue Frog Society originated, Vienna-Aspern: the 3<sup>rd</sup> performative walk on Urban Periphery, 2010. Photos by transparadiso.

Bottom: Barbara Holub, map of the Blue Frog Society\_A Habitat Without Territory, inkjet print on fabric, embroidery, 250 x 180 cm 64th UN/ NGO DPI conference, Bonn, 2011; Galerie im Traklhaus, Salzburg, 2011

[1] by Barbara Holub, Verlag für moderne Kunst Nürnberg, 2010  
[2] Hardt, Michael (2009): Production and Distribution of the Common\_A Few Questions for the Artist, in OPEN, 2009/16, NAI publishers  
[3] ibid.  
[4] curated by Jaroslav Anđel for the Czech Center, 2011, with the Austrian Cultural Forum, New York  
[5] Installation made possible by WCPUN and the Austrian Ministry of Education and Culture.

[www.transparadiso.com](http://www.transparadiso.com)  
[www.urban-matters.org](http://www.urban-matters.org)



# Transitions In Time

*A Conversation with Artur Mas,  
President of the Generalitat de Catalunya*

***At what point in your llfe did you become aware of your Catalan identity?***

The moment when many Catalans realize that we're Catalan is when we start speaking our language, so at a very young age. I was born in 1956, during Franco's dictatorship, when the official language in Catalonia was Spanish (Castilian). Catalan was prohibited, but not dead—it was saved on the streets, in the bars, churches, factories, theaters, village football teams, and in homes.... In my house, with my parents and siblings, we always spoke Catalan.

***Were there efforts to achieve greater sovereignty before?***

The subject of Catalonia's possible independence is rather recent, but the notion of Catalonia as a differentiated entity was born at the beginning of the Middle Ages. In the 10<sup>th</sup> century Catalonia already existed as such; it was the only territory south of the Pyrenees that belonged to the Carolingian Empire—for 10 centuries we have been intimately connected with Europe—whereas the rest of the Peninsula was practically entirely Arab and Muslim. The Catalan language was born and acquired great prestige and influence in the Middle Ages. Illustrious names such as Ramón Lull, Ausiàs March, Ramón Montaner, were influential across Europe. Our institutions were born, along with our culture and legal system, and in the 13<sup>th</sup> and 14<sup>th</sup> centuries, Catalonia was the principal commercial and maritime power of the Mediterranean. This makes us merchants, people of trade and dialogue, with a spirit that is quite removed from the empires that imposed themselves through arms and wars. We almost always imposed ourselves through commercial means. Thereafter, Catalonia experienced a period of less splendor, until we reached a critical point in our history with the War of Succession in the early 18<sup>th</sup> century, when France and Castile agreed to impose a new dynasty in Castile. Catalonia allied itself with the Austro-Hungarian Empire, England, Portugal and Holland.

There was a war and the Catalans were on the losing side. In 1714, by “Right of Conquest,” all of the State Institutions were annulled (some of which dated back to the 11<sup>th</sup> century)<sup>1</sup> along with Catalan freedoms, and two and a half centuries passed before we reclaimed anything. Throughout that period, without institutions, with our language prohibited, with trade with America—unlike the rest of Spain—cut off by the Hispanic authorities, all of the odds were that Catalonia would disappear. It resisted and in the 20<sup>th</sup> century, with the advent of the Second Republic, we regained our institutions. Then came Franco's long

***¿En que momento de su vida tomó Usted conciencia de su identidad catalana?***

El momento en el cual muchos catalanes nos damos cuenta de que somos catalanes es cuando empezamos a hablar catalán, es decir desde muy pequeñitos. Yo nací en el año 1956, en plena dictadura de Franco, en una época en que el idioma oficial y general era el castellano en Catalunya. El catalán estaba prohibido, pero no estaba muerto—se salvó en las calles, en los bares, en las iglesias y en las parroquias, en los talleres, en las fábricas, los ateneos, los casinos, los equipos de futbol de los pueblos, y en las casas.... En mi casa con mis padres y mis hermanos hablamos siempre en catalán.

***¿Había esfuerzos de lograr mayor soberanía antes?***

El tema que Catalunya se plantee una posible independencia es un tema bastante reciente, pero Catalunya, como un ente diferenciado, nace a principios de la Edad Media. En el siglo X, ya se puede decir que Catalunya existía; era el único territorio al sur de los Pirineos que pertenecía al Imperio Carolingio—desde hace ya diez siglos estamos íntimamente conectados con Europa—mientras el resto de la Península era prácticamente todo árabe y musulmán.

A partir de ahí nace la lengua propia, el catalán, una lengua de gran prestigio y gran proyección en toda la Edad Media. Hay nombres ilustres como Ramón Lull, Ausiàs March, Ramón Montaner, gente que tuvo una proyección europea y por tanto en aquel momento una proyección universal en lo que era el mundo de la época. A lo largo de la Edad Media nacen las instituciones, la cultura en general, el derecho, y además Catalunya se convierte en el siglo XIII y en el siglo XIV en la primera potencia comercial y marítimo de todo el Mediterráneo. Esto nos hace comerciantes, importante gente de trato, de diálogo y de negocio, con un espíritu bastante alejado de los imperios que se imponían a través de las armas o de las guerras.

Nosotros nos impusimos casi siempre a través del trato comercial. Después Catalunya pasa una época de no tanto esplendor, hasta que llega un punto crítico de nuestra historia, que es la Guerra de Sucesión a principios del siglo XVIII, cuando Francia y Castilla se ponen de acuerdo para imponer una dinastía nueva en Castilla. Catalunya se alía con el Imperio Austro-Húngaro, Inglaterra, Portugal y Holanda.

Hay una guerra y los catalanes nos pusimos en el bando perdedor. A partir de ahí, en el año 1714 por “Derecho de Conquista,” se anularon todas las Instituciones de Estado (algunas de las cuales se remontaban al Siglo XI )<sup>1</sup> y libertades catalanes y pasaron dos siglos y medio hasta que recuperamos alguna cosa. En dos siglos y medio sin instituciones, con el idioma prácticamente prohibido, con el comercio con América—a diferencia del resto de España—cortado por las autoridades hispánicas, todos los números de Catalunya eran para desaparecer. Resistió y entramos ya en el siglo XX, en la Segunda República Española y recuperamos nuestras instituciones. Después de esto vino la larga dictadura franquista y finalmente la recuperación de las instituciones otra vez, pero lo importante es que en estos dos siglos y medio, no se llegó a perder el catalán, no se perdió la cultura, se desarrolló una potente industria y floreció una sociedad civil muy activa y comprometida.



dictatorship. After that, we finally regained our institutions once again, but the important thing is that during those two and a half centuries, the Catalan language and culture were not lost, a powerful industry was developed, and an active and engaged civil society flourished.

***Speaking of civil society, the current political divisions are also manifested at the level of civil society. Are there efforts to encourage dialogue?***

There is the will to dialogue, especially as dialogue is very much a part of Catalan society. We are a mixed society. Over half of our 7.5 million inhabitants don't have a Catalan origin and there are no serious problems of coexistence. Catalonia has always had a very clear outward orientation, formed through commerce, dialogue, and trade; this creates a mentality of negotiation and consensus. In this vein, the will of Catalonia is to foster dialogue within Catalonia and outside with Madrid and with Brussels. There have always been people for independence within Catalonia, but they were a relatively small part of the society, approximately one-fifth of the population. In fact, for a long time most Catalans supported an understanding with Spain. Thirty-five years after Franco's death, we have the feeling that in Spain Catalonia is viewed as something difficult to fit in, as a people with a distinct character, who speak a different language, and who ask for money; when in fact it's the opposite; we transfer many resources to the rest of Spain. With the passage of time, more and more people in Catalonia have espoused positions which may not be strictly for independence, but advocate for Catalonia following its own path, which may not be the same one that we have followed in the last three decades... a path within Europe obviously, within the European Union.

***Hablando de sociedad civil, las divisiones políticas a nivel político también se manifiestan al nivel de la sociedad civil. ¿Hay esfuerzos de dialogar?***

La voluntad de diálogo la hay porque además es bastante consustancial a la sociedad catalana. Somos una sociedad de mezcla. Bastante más de la mitad de nuestra población de siete millones y medio de habitantes, no tienen un origen catalán y no hay problemas graves de convivencia. Catalunya siempre ha tenido una orientación muy clara hacia el exterior y como lo decía antes, se ha forjado a través del comercio y por tanto a través del diálogo y del trato, eso te da una mentalidad de negociación, de consenso. De acuerdo con eso, ahora también la voluntad de Catalunya es una voluntad de diálogo dentro de Catalunya y fuera de Catalunya con Madrid y con Bruselas. Siempre había gente independentista en Catalunya pero era una parte relativamente minoritaria de la sociedad, aproximadamente una quinta parte de la población. De hecho la apuesta mayoritaria de los catalanes durante mucho tiempo, fue un entendimiento con España. 35 años después de la muerte de Franco, tenemos la sensación que en España se sigue viendo Catalunya como algo difícil de encajar, como una gente que tiene un carácter distinto, que pide dinero—cuando de hecho es exactamente el revés, transferimos muchos recursos al resto de España—una gente que habla un idioma que no es el suyo. A medida que ha ido pasando el tiempo, cada vez ha habido más gente de la sociedad catalana que se ha ido decantando hacia posiciones que, no sé si son estrictamente independentistas...pero sí, hacia posiciones de decir que Catalunya tiene que seguir un camino propio, que no necesariamente tiene que ser el mismo que hemos seguido en las últimas décadas...un camino propio dentro de Europa, evidentemente, dentro de la Unión Europea.

[1] Parliamentary system, governmental system of checks and balances, judicial system, currency, defense and public order system.

[1] Sistema parlamentario, sistema de Gobierno de cheques y balances, sistema judicial propio, moneda, sistema propio de defensa y orden público.



***But a path within the European Union is not so obvious.***

Our desire is obvious and total. Legality is something else, but legality can be addressed with time. Many democratic countries change their constitution. European treaties could also change and the Spanish constitution could change as well if the will was there. The problem is not legality, the problem is will. You speak a lot about independence. We see this differently. What Catalonia would like is not a classic independence in the way countries are represented at the UN, but rather an international representation that wouldn't be ours directly, but instead through the European Union.

***This would suppose a political union that doesn't yet exist at the European level....***

Catalonia's independence also doesn't exist. Our project for the next few years is to see Catalonia as European, but with a different Europe than that which we have right now. We would like to see a political Europe similar to the United States of America, a political Europe with a capital in Brussels. We would have to cede a part of significant powers to Brussels. We would understand that our representation at the United Nations would be through a European union and we would want to be a state within the "United States of Europe" that would have the same competencies as other states. This is not very different from

***Pero un camino propio dentro de la Unión Europea no es tan evidente....***

Nuestro deseo sí es evidente, es total. Otra cosa es la legalidad, pero la legalidad afortunadamente se puede ir acompasando con el paso del tiempo. Hay muchos países democráticos que su constitución la cambian cada dos por tres y no pasa nada. Por tanto los tratados europeos se pueden cambiar y la constitución española también se podría cambiar si hubiera voluntad. El problema no es la legalidad, el problema es la voluntad. Usted habla mucho de independencia. Nosotros, esto lo vemos un poco distinto. Lo que le gustaría Catalunya es no tanto una independencia clásica en función de como los países están en la ONU, sino que nuestra representación internacional en los grandes organismos no fuera de nuestros países directamente, sino a través de la Unión Europea.

***Esto supondría una unión política que todavía no existe a nivel europeo....***

Tampoco existe la independencia de Catalunya. Nuestro proyecto, como nos gustaría ver Catalunya en estos próximos años...nos gustaría verla europea pero con una Europa distinta de la que tenemos. Nos gustaría una Europa política igual que los Estados Unidos de América, una Europa política con una capital federal que no estaría en Barcelona, estaría en Bruselas. Nosotros tendríamos que ceder como estado futuro una parte de

what happens in the United States of America. If Europe were to become the United States of Europe, we would want to be like Massachusetts; Massachusetts is not independent, it does not have a seat at the UN or the IMF.

***The big countries of the EU would not agree to the proposal of abandoning their direct representation at the international level.***

Here we are in agreement, but this is our project. In the short term, for sure, it will not happen, but as things evolve we believe this will be the only project that will be beneficial for Europe.

***If independence were achieved, would Catalonia support the independence of other peoples, as in Tibet, or Chechnya, despite having important economic ties with China or Russia?***

China is an important partner for Catalonia but Catalonia, by definition, would always be close to those countries that are in a similar situation to ours...we have done this in the Sahara, in the case of Morocco. The democratic principle stipulates that all peoples of the world have the right to constitute themselves into their own state. The issue is to verify that processes are democratic and meet determined norms. This is the case of Catalonia. We are saying, "let us vote." We are not asking for independence directly. We are requesting that they let us vote (as was the case in Quebec a few years ago, or as may be the case in Scotland in a year and a half) and that if, from the vote, a social majority in Catalonia emerges with a significant participation in the elections that calls for Catalonia to become an independent state, that we could then negotiate on the basis of the majority will of the Catalans. We wouldn't want to impose independence. What we want for ourselves we must also want for others. Taking into consideration the criteria of democratic process, important social majority, strong participation in elections...this could happen in any country of the world.

***But if the country is too strong there is no possibility....***

Canada and the United Kingdom are great countries founded in democracy and in the defense of human rights. When they found themselves in situations like that which Spain is confronting now they didn't resolve it by saying, "here is a law that can't be touched, you can't even vote;" what they do is allow a vote to happen, collaborate on the voting on the basis of agreements and wait to see the results. What occurred in Quebec, twice consecutively, is that the result was never in favor of Quebec's independence. There's also an interesting resolution of the Supreme Court of Canada that states that even if the referendum had been won in Quebec, Quebec's independence could not have been proclaimed automatically. Rather, Canada would have the democratic obligation to meet with the authorities in Quebec to negotiate a process of self-determination. This is what we are asking for and what the Spanish state has not been disposed to consider, despite being a state of the European Union founded in democracy, unlike Russia and China that have distinct political systems.

***What would Catalonia do differently if it were an independent state?***

We would want to develop greater infrastructures of connection with Europe and with the world; electrical and telecommunication networks, as well as intercontinental flights. We would have more resources to invest in research. Presently, Catalonia constitutes 1% of world scientific production whereas we constitute only 0.1% of the world's population, so our scientific weight is increasingly significant. We would develop this policy with much greater

poderes significativos a Bruselas. Entenderíamos que nuestra representación en las Naciones Unidas fuera a través de una unión europea, y quisiéramos en ese esquema ser un estado dentro de los Estados Unidos Europeos que tuviera las mismas competencias que tienen los demás estados. Esto no es muy distinto de lo que ocurre en los Estados Unidos de América. Si Europa se convierte en los Estados Unidos de Europa, nosotros queremos ser Massachusetts; Massachusetts no es independiente, no tiene una silla la ONU ni en el FMI.

***Los grandes países de la UE no estarían de acuerdo con el propósito de abandonar su representación directa a nivel internacional.***

Aquí estamos de acuerdo pero nuestro proyecto es éste. A corto plazo no va a salir, seguro. Pero tal como evolucionan las cosas, creemos que el único proyecto que es bueno para Europa con el paso del tiempo va a ser éste.

***¿Si se lograba la independencia, Catalunya apoyaría la independencia de otros pueblos como los de Tíbet o Chechenia a pesar de tener relaciones económicas importantes con China o Rusia?***

China es un socio importante para Catalunya, pero Catalunya por definición estaría siempre cerca de aquellos países que están en una situación similar a la nuestra...lo hemos hecho respecto al Sahara, en el caso de Marruecos. El principio democrático dice que todos los pueblos del mundo tienen derecho, si quieren, a poder constituirse en un estado propio. El tema es comprobar si los procesos son democráticos, si cumplen determinadas normas. Es el caso de Catalunya. Nosotros decimos, déjenos votar. No estamos pidiendo directamente la independencia. Lo que pedimos es que nos dejen votar y, si de la votación sale—como pudo salir en Quebec hace unos años atrás o puede salir en Escocia dentro de un año y medio—una mayoría social en Catalunya clara con un a participación significativa en las elecciones que dice, "Catalunya: un estado propio," entonces lo que pedimos es que se negocie esta voluntad mayoritaria de los catalanes. Tampoco la queremos imponer. Lo que queremos para nosotros no podemos dejar de quererlo para los demás, siempre y cuando haya ese criterio de procesos democráticos, mayoría sociales importantes, participaciones grandes en las elecciones, eso se puede dar en cualquier otro país del mundo.

***Pero si el país pese demasiado no hay una posibilidad real...***

Canadá y el Reino Unido son grandes países fundamentados en la democracia y en la defensa de los derechos humanos. Cuando se han encontrado en situaciones como las en que se esta encontrando España, no la resuelvan a base de decir aquí tenéis una ley que no se puede tocar, no podéis ni votar; lo que hacen es dejar que se vote, colaborar en la votación a nivel de acuerdos y a partir de allí impactar las preguntas y ver el resultado. Lo que ocurrió en Quebec hasta ahora por dos veces consecutivas es que el resultado nunca fue a favor de la independencia del Quebec. También hay una resolución muy interesante de la Corte Suprema del Canadá que dice que si se hubiera ganado el referéndum en el Quebec, no se hubiera podido proclamar automáticamente la independencia del Quebec, pero que la Federación del Canadá hubiera tenido la obligación democrática de sentarse con las autoridades del Quebec a negociar un proceso de autodeterminación. Eso es lo que nosotros pedimos y que de momento el estado español parece que no esta dispuesto a poner encima de la mesa, a pesar de que es un estado de la Unión Europea que se







depth. We would also focus on a policy of internationalizing our culture and our economy. We would develop a more powerful education system. We have a practice that applies to education, as well as to health, social services, and many other things, namely the collaboration between the public and private sectors. In Spain, these matters are almost entirely public. In Catalonia, there is an interesting mix between public and private initiative that we would strengthen.

fundamenta en la democracia, a diferencia de Rusia y China que tienen sistemas distintos y otro concepto de la política.

**¿Qué haría Catalunya de manera diferente si fuera un estado independiente?**

Querríamos desarrollar las grandes infraestructuras de conexión con Europa y con el mundo, redes de interconexión eléctrica, de telecomunicación y los vuelos intercontinentales. Dispondríamos de mas recursos para invertir en la investigación. En este momento Catalunya representa un 1% de la producción científica mundial y en cambio representamos un 0,1% de la población mundial, con lo cual nuestro peso científico cada vez es más significativo. Esta política, la desarrollaríamos con mucho mayor profundidad. Otra cosa que podríamos hacer mejor es la política de internacionalización de nuestra cultura y de nuestra economía. También desarrollaríamos un sistema educativo más potente. Tenemos un fundamento que vale para la educación, pero también vale para la sanidad, los servicios sociales y muchas otras cosas, que es la colaboración entre el mundo público y el mundo privado. En España las cosas son casi todas públicas en este sentido. En Catalunya hay un mix bastante interesante entre iniciativa pública e iniciativa privada que podríamos fortalecer.

Images of the Palau de la Generalitat (Main hall and Sala Tàpies) courtesy of the Generalitat de Catalunya.

www.president.cat  
www.gencat.cat



## Culture and Conviction: The Legacy of Pau Casals

**THE WORDS OF PAU CASALS AT THE UN October 24, 1971**

“This is the greatest honour of my life. Peace has always been my greatest concern. I learnt to love it when I was but a child. When I was a boy, my mother, an exceptional, marvelous woman, would talk to me about peace, because at that time there were also many wars. What is more, I am Catalan. Catalonia had the first democratic parliament, well before England did. And the first United Nations were in my country. At that time, in the 11<sup>th</sup> century, there was a meeting in Toluges (now France) to talk about peace, because in that epoch Catalans were already against, AGAINST war. That is why the United Nations, which works solely towards the peace ideal, is in my heart, because anything to do with peace goes straight to my heart.”

“I have not played the cello in public for many years, but I feel that the time has come to play again. I am going to play a melody from Catalan folklore: ‘El cant dels ocells.’ Birds sing when they are in the sky, they sing: ‘Peace, Peace, Peace,’ and it is a melody that Bach, Beethoven and all the greats would have admired and loved. What is more, it is born in the soul of my people, Catalonia.”

One of the greatest musicians of the 20<sup>th</sup> century, Catalan cellist Pau Casals (1876-1973), was the protégé of Queen Maria Christina of Spain and at the age of 22 performed for Queen Victoria. In 1904 he performed for the US President Theodore Roosevelt in the White House and later in 1961 for President John F. Kennedy. In 1939 Casals went into self imposed exile

to protest against fascism in Spain and later, after World War II, he silenced his cello for 30 years in protest against the West’s inaction against fascism. Casals was a man of inflexible conscience, of passion and intense commitment to humanitarian causes. In 1963, John F. Kennedy awarded him the Presidential Medal of Freedom and in 1971 he was awarded the Medal of Peace of the United Nations.



Photos of Pau Casals performing at the United Nations in 1971 provided by the Fundació Pau Casals.

Speech translated from the catalan version of the book by Enric Casals, PAU CASALS, dades biogràfiques inèdites, cartes íntimes i records viscuts. Editorial Pòrtic. Col·lecció Memòries. Barcelona, 1979.

www.paucasals.org



# ‘Més Que Un Club’

## **What are your goals as President of FC Barcelona?**

This club is over 100 years old; it is the property of more than 170,000 members and has always been a major defender of the values of democracy. Being president of FC Barcelona is a huge honour for any member. The goals are to improve the club in every aspect and ensure that the team continues setting worldwide standards and fighting for all titles, but beyond the present, our challenge is to think about the future and to reaffirm the pillars that make Barça great. So we need the club to be strong socially, and strong financially, and that will mean reducing our bank debt if we are going to commit to new projects such as the new stadium and the new pavilion. We need the club to have strong assets because that is the best way to ensure our independence. All of those are goals of our board, but as president of Barça my dream is for our team to continue to be loved by children all around the world, and for the club to be admired for what it is and what it represents.

## **It is said that Barça is “Més que un club,” “more than a club.” What is the basis for that statement and how do you ensure that it stays true over time?**

That is our slogan and that is what defines us. We don’t think we are just a sport association, nor do we only live by our results. Throughout its history, Barça has been deep-rooted in Barcelona and in Catalonia and we have always been part of the society around us. “More than a club” expresses our commitment to that society. The saying was first coined by an ex-president of Barça, Narcís de Carreras, in 1968, when the political context in Spain was that of a dictatorship that did not allow freedom of expression to Catalan society. Barça became a vehicle for the expression of the Catalan identity and so it became more than a mere football club. But nowadays, that slogan means many other things. We are also “more than a club,” because Barça belongs to its 170,000 members, because it has 13 different sports sections, because it defends certain values, because it is committed to the less privileged, especially children, and because it has such a unique way of playing. Barça is not just about winning or losing; it’s much more than that.

## **Has the La Masia model, which FCB is famous for, been emulated by other Clubs?**

The Masia model is unique. It is part of the club’s DNA. When the first Masia was created 30 years ago, it was an old country estate that was used as a residence for young footballers. Children from outside Barcelona that had come in search of a dream lived there, the dream of playing for the Barça first team. That has evolved since, and the new Masia is a modern 6,000 square meter facility that we inaugurated in 2011 at the Ciutat Esportiva Joan Gamper. But as a concept, it has come to symbolise our sporting identity, which is our dependence on home-bred talent, and also a school where values are taught to educate not only sportspeople, but good people too. But we never forget that not all the players in the youth system will reach the first team or become professional players. So it is our responsibility to provide the groundwork for them to go to university or learn a trade. Sportspeople matter to us, but the human side that will affect their whole lives matters more. Another thing that makes



## *An Interview with FC Barcelona President, Sandro Rosell*

## **Quins son els seus objectius com a president del FCB?**

El nostre és un club centenari, que és propietat de 170.000 socis i que sempre ha estat un gran defensor dels valors democràtics. Ser President del FC Barcelona és un gran honor per qualsevol soci. Els objectius son millorar el Club en totes les seves facetes i assegurar que l’equip segueixi sent una referència al món i que lluiti per tots els títols, però més enllà del present, la nostra responsabilitat és pensar en el futur i en reafirmar els pilars que fan fort el Barça. Per això hem de tenir un club fort socialment, fort econòmicament i això passa per reduir el deute amb els bancs si volem cometre projectes com el futur Estadi i un nou pavelló. Necessitem un club fort patrimonial ment perquè això és la millor garantia per preservar la nostre independència. Tot això forma part dels nostres objectius com a junta directiva, però com a president del Barça tinc el somni de que el nostre segueixi sent un club estimat pels nens del món, que sigui un club admirat pel que és i pel que representa.

## **Es diu que el Barça es “Més que un club,” quina es la base d’aquesta declaració i com es pot assegurar que es manté vigent amb el pas del temps?**

Aquest és el nostre lema, el que ens defineix. No ens considerem únicament una associació esportiva, ni vivim únicament dels resultats. Al llarg de la seva historia, el Barça ha estat arrelat a

us different is the way we teach children from a very young age to play football in a special way: Spectacular and offense-based football rooted in creativity, ball possession, and teamwork. We have had a 30-year head start on all other clubs in that respect.

## **Could you describe the aims of the FCB Foundation?**

The FC Barcelona Foundation was founded in 1994 and is the entity through which the club organises its corporate social responsibility. It is mainly financed by the 0.7% donated from FC Barcelona’s own ordinary income and the 0.5% of all of the club’s professional sportspeople and staff. All of the projects are based on the premise of using sport as a core element to foster and educate positive values through campaigns, programmes and alliances. The main beneficiaries are children and youth in at-risk situations.

## **How did FCB Foundation’s partnership with UNICEF develop?**

We are convinced that union creates strength and that our corporate social responsibility has to increase and develop hand in hand with charitable organisations of major prestige and proven rigour, as are the cases with the Bill & Melinda Gates Foundation, the Pies Descalzos Foundation and UNICEF, which is undoubtedly the entity that has established the road-map for charity work with children. FC Barcelona donates 1.5 million euros a year to UNICEF to set up joint charity projects. After almost seven years of the alliance, we can safely say that Barça and UNICEF form a very good team. At present, we have shared projects in Brazil, Ghana, South Africa and China.

Barcelona i a Catalunya i sempre hem format part de la societat que ens envolta. El “més que un club” expressa el nostre compromís amb la societat. Aquesta divisa la va pronunciar per primera vegada un ex president del Barça, Narcís de Carreras, al 1968, quan el context polític a Espanya era el d’una dictadura que no deixava que la societat catalana s’expressés lliurement. El Barça va ser un vehicle d’expressió de la identitat catalana i per això és més que un club de futbol. Però aquesta frase avui en dia inclou moltes més coses. També som ‘més que un club’ perquè el Barça és propietat dels seus 170.000 socis, perquè compta amb 13 seccions esportives, perquè defensa uns valors, perquè te un compromís solidari amb els més desfavorits, sobretot els nens...perquè te un estil de joc molt singular. El Barça no es només guanyar o perdre, és molt més que això.

## **El famós model de la Masia del FCB ha estat imitat per altres clubs?**

l model de la Masia és únic. Forma part del nostre ADN com a club. Fa 30 anys, quan es va crear la primera Masia, era una casa de camp que servia com a residència de futbolistes. Acollià a nens que venien de fora de Barcelona a la recerca d’un somni, el de jugar al primer equip del Barça. Actualment això ha evolucionat i la nova Masia és un modern edifici de 6.000 metres quadrats que vam inaugurar al 2011 a la Ciutat Esportiva Joan Gamper, però



**FCB's founder was originally a Swiss national. How is Catalan culture reflected in the Club?**

Hans Gamper and a group of foreign and Catalan friends with an interest in what was an unknown sport at the time called 'football' founded the club in 1899. Gamper integrated in Catalonia and became Catalan himself, adopting the name of Joan, and remaining grateful to the country that welcomed him. Gamper was a player, director and president, but most of all he was a visionary who laid the foundations on which the club was built. He imagined a democratic sports society, freely governed by its members, who would be its owners, and created the meaning that would mark the club universally: its commitment to Barcelona and Catalonia. The foundations I am talking about are Catalanism, democracy, multiple sports and universality. And 113 years later, these foundations are still as strong and valid as they were the very first day.

**How does Barça reconcile its strong Catalan identity with its universal appeal?**

Our club is bound to its identity, to its values, to its roots, to its history, which all form part of the traditions, culture and language of Catalonia. But at the same time, we are a global club; we have 1,500 Barça supporters clubs and we have 350 million followers. We work to be as close as we can to these fans and social networks are a basic element for achieving that. Our website is in seven languages, and we are the leaders on Twitter, Facebook and YouTube. It's when you travel that you really appreciate how hugely global this club is. The word Barça is known all over the world and people say it with admiration and respect.

**As a Catalan club, how has the sponsorship of Qatar Foundation prominently displayed on the players' shirts been received by the players and the public?**

Our club had always wanted our shirt to be free from advertising, but the current economic situation and the need for extraordinary income to be able to compete with the biggest clubs in the world obliged us to rethink the situation. In 2003, the members at our assembly passed the motion for our shirt to possibly one day carry advertising. As no offers came in that matched the values the club deserves, the former board went for the option of advertising UNICEF, which was a great decision. But financial needs meant we had to find a sponsor, and we managed to convince Qatar Sports Investments to go for Barça. Their financial contribution is very important for the club and our relationship with the Qatar Foundation has been fantastic for the first two years, and from now on we'll be wearing the name of Qatar Airways on our shirts. Barça is a huge club and generates plenty of talk in the media, but we took this decision to the members' assembly and it was passed by a large majority.

**It is often said that sports can be a vehicle for peace and cooperation. Can you cite concrete examples of ways in which Barça accomplishes this?**

Nelson Mandela said that sports can change the world. It has the power to inspire, to unite people in a way that is rarely achieved. FC Barcelona firmly believes in the values of sport and has the capacity to use the universal language of football to unite peoples. It was with this goal in mind that we recently visited Israel and Palestine with our players. We know that we are very popular there, that we have a lot of followers, and we wanted to make a gesture to contribute to building bridges of peace. Barça is something that Palestinians and Israelis have in common, so why not utilize that in favour of peace? We have to strengthen trust, respect and understanding between the two peoples. Sport, football, can be a great instrument for dialogue that helps move towards reconciliation.



com a concepte s'ha convertit en el símbol de la nostra identitat esportiva, que és l'aposta pels jugadors fets a casa, i també en una escola de valors que forma esportistes però sobretot persones. Perquè mai oblidem que no tots els jugadors que estan als equips inferiors arribaran al primer equip o a ser futbolistes professionals. Per això tenim la responsabilitat de donar-los les eines perquè en el futur puguin desenvolupar una carrera universitària o una feina. Ens importa l'esportista, però sobretot el ser humà que serà tota la seva vida. En això crec que ens diferenciem dels que volen imitar el nostre model. I un altre aspecte que ens distingeix dels demés és que des que son petits ensenyem als nostres jugadors a jugar al futbol amb un estil diferent. Es un futbol ofensiu i espectacular basat en la creativitat, en la possessió de la pilota y en l'associació amb el company. En tot això portem una avantatge de 30 anys respecte a altres clubs.

**Podria descriure els objectius de la Fundació FCB?**

La Fundació del FC Barcelona es va fundar l'any 1994 i és l'entitat a través de la qual el Club vehicula la seva responsabilitat social corporativa. Es finança, principalment, gràcies al 0,7% dels ingressos ordinaris del FC Barcelona i al 0,5% dels sous dels esportistes i l'estaf professional del Club. Tots els projectes que desenvolupa estan basats en premisses com la utilització de l'esport com a eix vertebrador i el foment de l'educació i dels valors positius a través de campanyes, programes i aliances. Els principals beneficiaris són els infants i els joves en situació de vulnerabilitat.

**Com s'ha desenvolupat la col·laboració de la Fundació FCB amb UNICEF?**

Estem convençuts que la unió fa la força i que la nostra responsabilitat social corporativa ha de créixer i desenvoluparse també de la mà d'entitats socials de gran prestigi i contrastat rigor, com és el cas de la Bill & Melinda Gates Foundation, de la Fundació Peus descalços o d'Unicef, sens dubte l'entitat que marca el full de ruta al treball social a favor de la infància al món. El FC Barcelona dona a Unicef 1,5 milions d'euros a l'any per posar el marxa conjuntament projectes socials. En l'actualitat, tenim projectes comuns al Brasil, Ghana, Sud-àfrica i la Xina, basats en un altre dels nostres objectius compartits: l'esport i els valors.

**Com concilia el Barça la seva forta identitat catalana amb la seva vocació universal?**

El nostre és un club lligat a la seva identitat, als seus valors, a les seves arrels, a la seva història, que formen part de les tradicions, la cultura i la llengua de Catalunya. Però al mateix temps som un club global, tenim 1.500 penyes barcelonistes a tot el món y tenim 350 milions de seguidors. Treballem per estar a prop d'aquests fans i les xarxes socials són bàsiques per fer-ho. Tenim una web en set idiomes, som líders a Twitter, Facebook i Youtube. Quan viatges te'n adones d'aquesta dimensió global que te el club. La paraula Barça és una paraula coneguda a tot arreu i la gent la pronuncia amb admiració i respecte.

**Com club català, com es va rebre el patrocini de Qatar Foundation a la samarreta pels jugadors i el públic?**

El nostre club sempre ha intentat que la seva samarreta estigués neta de publicitat però la conjuntura econòmica i la necessitat d'obtenir ingressos atípics per poder competir amb els millors clubs del món ens va obligar a replantejar la situació. El 2003, els socis van aprovar en assemblea poder posar algun dia publicitat comercial a la samarreta. Atès que no va arribar una oferta d'acord amb el valor que mereixia el Club, l'antiga directiva va optar per l'opció de publicitar Unicef, que va ser una gran decisió. Però la necessitat econòmica ens va obligar a buscar un patrocinador i aconseguim convèncer Qatar Sports Investments que apostés pel Barça. La seva aportació econòmica és molt important per al club i la nostra relació amb Qatar Foundation aquests dos primers anys ha estat fantàstica, i a partir de la temporada que portarem Qatar Airways a la samarreta. El Barça és un club molt gran i genera grans debats mediàtics, però portem aquesta decisió a l'assemblea de socis i va ser aprovada per àmplia majoria.



**Sovint es diu que l'esport pot ser un vehicle per a la pau i la cooperació. Pot donar exemples concrets de la manera com el Barça aconsegueix això?**

Nelson Mandela deia que l'esport té el poder de canviar el món. Té el poder d'inspirar, de poder unir a la gent d'una manera que pocs aconsegueixen. El FC Barcelona creu fermament en els valors de l'esport i té la capacitat d'utilitzar el llenguatge universal del futbol per unir els pobles. Amb aquest objectiu vam visitar recentment Israel i Palestina, vam anar amb tots els nostres jugadors. Sabem que som molt populars allà, que tenim molts seguidors, i vam voler fer un gest per contribuir a tendir ponts de pau. El Barça és quelcom que tenen en comú palestins i israelians, perquè no aprofitar-ho en favor de la pau? Hi ha que enfortir la confiança, el respecte i la comprensió entre els dos pobles. L'esport, el futbol, pot ser un gran instrument per tendir ponts de diàleg que ajudin a la reconciliació.

Photos courtesy of FC Barcelona  
www.fcbarcelona.com





# A DAY IN THE WORLD

London, UK, 19:58.

*At this time of day there are more than a million passengers in the sky worldwide. Air travel is cheaper than ever but it has lost its glamour. The upside is the variety of inflight entertainment now available.*  
Photo by REZA

[www.aday.org](http://www aday.org)  
© Max Ström



# Basque Society in the 21<sup>st</sup> Century

*with Iñigo Urkullu, Lehendakari*



We are a people of two and a half million inhabitants living in two states: the southeast of France and the north of Spain. We have three juridical/administrative structures: two in the Spanish state, divided by autonomous communities—the Autonomous Community of the Basque Country and the Foral Community of Navarra—and in the French state there is no such administrative structure for the Basque people.

This past 31<sup>st</sup> of July, the Nationalist Basque Party (PNV), which I preside, marked 117 years of history. The party's founder did believe that the Basque were a different race, but we're talking about the year 1895, and so his belief has to be contextualized in that historical moment. I don't believe us to be a different race. In fact there is a thesis arguing that we have a connection with the Caucuses, and specific bonds with Georgia. It's true that throughout these 21 centuries of history, the Basque people have demonstrated their resistance to invasions by other cultures. Why? Here is where the legends begin. Perhaps the only reason is because we have a small mountainous territory, with little arable land, poor in natural resources, and therefore of little interest to potential invaders.

I have to fight with those who identify nationalism with a racist movement. There is a distortion of the concept of nationalism that we defend as nationalists in the 21<sup>st</sup> century. Until last year, the Basque people lived through two centuries without knowing what it was like to live in peace. In the 19<sup>th</sup> century, the struggle for the dynastic monarchy in Spain had a strong impact; in the 20<sup>th</sup> century, the period of the Republic was also tumultuous in the Basque country, as in the rest of the Spanish state. And during Franco's regime, in 1959, ETA, a terrorist organization emerged. ETA initially emerged as an excision of the party that I preside, founded by young militants as a critique of the leadership of their own party, whom they blamed for insufficient action against Franco's dictatorial regime.

In the mid-sixties, confronted with the flow of immigration to the Basque country as a result of industrialization, the terrorist organization then acquired another characteristic, beyond its political foundation, namely to distinguish between Basque and non-Basque cultural identities. In the seventies, there was yet another component added, as an extension of Marxist-Leninist ideology, derived from the leftist liberation movements that were occurring in Algeria, Cuba, Nicaragua, etc. Between 1959 and 1968, the terrorist organization didn't commit attacks. Beginning in 1968, the attacks began, first targeting the military representatives of the Spanish state in the autonomous communities, and the Spanish military and political establishment more broadly.

Somos un pueblo que tiene dos millones y medio de habitantes y que vive en dos estados: el suroeste del Estado francés y el norte del Estado español. Tenemos tres estructuras jurídico administrativas: dos en el Estado español, divididas por comunidades autónomas—la Comunidad Autónoma del País Vasco y la Comunidad Foral de Navarra—y en el Estado francés no hay una estructura administrativa propia de la parte que afectaría al Pueblo vasco.

El pasado 31 de julio, el Partido Nacionalista Vasco (PNV), del que soy presidente, ha cumplido 117 años de historia. El fundador del partido sí entendía que los vascos éramos una raza diferente, pero estamos hablando del año 1895, y por lo tanto hay que contextualizarlo en aquel momento histórico. Yo no creo que seamos una raza diferente. De hecho hay una tesis que defiende que nosotros tenemos una cierta conexión con la raza caucásica, incluso con una relación de hermandad con Georgia. Es verdad que durante estos 21 siglos de historia el Pueblo vasco ha mostrado su resistencia a lo que han sido invasiones de otras culturas. ¿Por qué? Ahí comienzan las leyendas. Quizá la única razón sea que somos un territorio muy pequeño, con mucho monte, con poca extensión de terreno para ser cultivada, un territorio pobre en cuanto a recursos naturales que no interesara a los pueblos que hubieran podido invadirlo.

Tengo que pelear con aquellos que pretenden identificar nacionalismo con lo que es un movimiento racista. Hay una distorsión del concepto de nacionalismo que nosotros defendemos como nacionalistas en el siglo XXI. Hasta el año pasado el Pueblo vasco ha vivido dos siglos sin conocer realmente lo que es vivir en paz. En el siglo XIX la lucha por la dinastía monárquica en el Estado español tuvo una incidencia importante; el siglo XX, el tiempo de la República, fue también un periodo convulso en el País Vasco

From the first moment, the PNV, which exists since 1895, rejected the use of violence for political aims. The terrorist organization emerged in 1959, and therefore can't claim to own the nationalist ideology that precedes it.

Members of the PNV also died as victims of ETA, although not in numbers that would be remotely comparable to the losses suffered by the other Parties. The PNV was always against the violence, both from a human standpoint, and for political reasons, because it's nationalism in its entirety that has been hurt by the practice of violence, as all other Parties begin to identify nationalism with violence. Therefore, those of us who are pacifist or anti-violence nationalists are directly affected by the negative image.

The sentiment differs according to one's generation. Until 1970, I think people in Spain thought of the Basque as a hard-working, serious people that had suffered greatly during Spain's civil war and that had struggled against Franco's regime. However, the terrorist phenomenon damaged that image. From 1997-98 until 2004 was a particularly complicated time. In 1998, a kidnapping and assassination of a young member of Spain's governing Party at the time set off a chain of protests throughout the Spanish state. Despite Basques having participated in those protests, there was a moment when many protesters began yelling "Basques equal terrorists." So now not only nationalists, but all Basques, were considered terrorists. It's clear that those who used violence in the name of nationalism and in the name of Basque people have done the most to harm the Basque people and the nationalist movement. At the cultural level, there were also consequences, because if one believes "Basques equal terrorists," it follows that the Basque language, Euskera, is also something to be condemned and attacked. Fortunately, we are now overcoming this phase. On October 20<sup>th</sup>, 2011, ETA announced a definitive cease of its armed actions and we are now engaged in what will be a long and slow process of establishing the rules of coexistence among all concerned in Basque country.

Our objective is to have not just a political presence in the international arena, but also a cultural one. We have our own folklore, music, dress, ethnographic culture and anthropology. We have our own ancestral legislative system within the Spanish and French states, an administrative system dating back to the Middle Ages with at first unwritten and then written laws. Our language, Euskera, is unique to the Basques and, despite dialectal variances, is the same language on both sides of the Pyrenees. The Academy of Basque Language is over 100 years old and has fomented the development of the language. Euskera is a pre-Indo-European language that has no relationship to other languages around the world, neither to Spanish, Catalan, French, which are all Latin Indo-European languages, nor to the Celtic languages. In the seventies, Euskera underwent a process of alphabetical and grammatical unification, which provoked controversy among

como lo fue en el conjunto del Estado español; y durante el régimen franquista, en 1959, surge una organización terrorista. ETA surge en principio como una escisión del Partido que yo presido, con un primer planteamiento de crítica de algunos jóvenes militantes a los dirigentes de su propio Partido, porque pensaban que los dirigentes no estaban haciendo lo suficiente en contra del régimen dictatorial.

A mediados de los sesenta, ante el fenómeno de inmigración al País Vasco como consecuencia del segundo proceso de industrialización, se da también una característica de esa organización terrorista de intentar identificar ya no solo al régimen político sino intentar mostrar socialmente una barrera cultural de identificación de lo vasco con lo no-vasco. En la década de los setenta se añade otro componente, como es la influencia de los movimientos de liberación internacionales en Argelia, en Cuba, los fenómenos de Nicaragua, así como la extensión de la ideología marxista-leninista. Dentro de la propia organización terrorista entre 1959 y 1968 no se habían producido atentados. Es a partir del año 68 cuando empiezan a cometerse atentados, en principio contra representantes militares del Estado español en la CAV y la Comunidad Foral de Navarra o contra el estamento militar y político del Estado español.

Desde el primer momento, como Partido Nacionalista Vasco que existe desde 1895, venimos rechazando la práctica de la violencia con fines políticos. La organización terrorista surge en 1959, por lo que no puede asumir el patrimonio de la ideología nacionalista que es muy anterior. También nosotros, en nuestra medida, hemos sufrido las consecuencias en pérdida de vidas humanas, personas del PNV han perdido la vida como consecuencia de atentados y yo mismo he figurado en listas de amenazados por la organización terrorista. En cualquier caso esta situación no es comparable en modo alguno con lo vivido en el Partido Popular o el Partido Socialista, que han perdido muchas personas sólo por el hecho de pertenecer a estos dos Partidos políticos. El PNV ha sido siempre radicalmente contrario a la violencia practicada por esta organización terrorista. Desde luego desde una razón humana, pero además desde una razón política, porque es el nacionalismo en su conjunto el que se ve perjudicado por la práctica de la violencia, dado que todos los demás Partidos se suman al recurso fácil de identificar nacionalismo con violencia. Así, quienes somos nacionalistas pacifistas o anti-violentos nos vemos también directamente afectados por una mala imagen política.

El sentimiento es diferente en función de que se pertenezca a una u otra generación. Hasta el año 1970, creo que la gente en España identificaba al vasco como un Pueblo trabajador, serio, que había sufrido con especial incidencia la guerra civil y había luchado contra el franquismo, pero el fenómeno del terrorismo perjudica a la imagen de lo vasco. Vivimos un periodo muy complicado entre 1997-98 y el año 2004 en el Estado español. El año 1998, con un Gobierno en España del Partido Popular, se cometió un atentado con secuestro previo contra un joven de este Partido y se desencadenó un proceso de manifestaciones de repulsa en todo el Estado español. A pesar de que nosotros participamos en la convocatoria y organización de las manifesta

\*Lehendakari refers to the President of the Basque Government.



Basque-speakers, dividing the purists from those of us who consider ourselves modernist innovators seeking a common grammatical structure. The conflict was resolved and today we have an educational system based on a model of a unified language, although people continue to speak their own dialect at home. We are undertaking an effort to train professors of the educational system so they can teach in Euskera. It is a long and costly process that we are engaging in with dedication and confidence.

It was a language on the verge of disappearance due to various factors: On the one hand, at the beginning of the 20<sup>th</sup> century, a rapid industrialization of the Basque country with a massive influx of people from other communities, which resulted in the imposition of the Spanish language over Euskera; on the other hand, throughout much of the 20<sup>th</sup> century, a clear prohibition by the dictatorial franquist regime of the use of languages like Euskera or Catalan. Looking to the future, and taking into account globalization and the influence of media, we are concerned about the low daily use of Euskera among young people. A recent sociolinguistic survey established that 60% of youth under 16 are bilingual. Nonetheless, the use of Euskera on the street is lower and is subject to the trends generated by the languages that dominate the mainstream media.

We are dedicated to knowing which other languages in the world are in a similar situation to Euskera, in terms of declining use and the risk of disappearance. We are very interested in the languages spoken in the Americas, such as Guaraní, or the Maya and Inca languages, as well as in the evolution of European languages such as Gaelic or Talmi in Holland. We want to maintain a relationship with Indigenous Peoples and their cultures. As Basques, we have special care for all people that suffer oppression or dictatorship. UNESCO has its own “house” in Euskadi (Basque country) and we aspire towards a permanent representation at the United Nations, as an observer, in a first instance. We consider the UN to be an organization that should serve as an instrument to ensure that all Peoples are respected. We are an open People, committed to maintaining and developing our identity in the 21<sup>st</sup> century.

ciones, hubo un momento en el que muchos de los manifestantes llegaron a gritar “vascos igual a terroristas.” Ya no solamente los nacionalistas, sino todo vasco era igual a terrorista. Por lo tanto, es indudable que quien ha usado la violencia en nombre del nacionalismo y en nombre del Pueblo vasco ha sido quien ha hecho daño al Pueblo y al nacionalismo vasco. Esto, llevado también al orden cultural, tiene su incidencia, porque si uno piensa “vasco igual a terrorista,” pues lo mismo puede pensar en relación al idioma: “el euskera es el idioma de los vascos, por lo tanto el euskera es algo que hay que despreciar y hay que atacar.” Afortunadamente vamos superando esa etapa. El 20 de octubre de 2011 la organización terrorista emitió un comunicado por el que anunciaba el cese definitivo de su acción armada y nos encontramos ahora en un proceso que será lento y largo para intentar profundizar en las reglas de convivencia entre diferentes en el seno del País Vasco.

Nuestro propósito es tener una presencia en el ámbito internacional no solamente presencia política sino también cultural. Tenemos nuestro propio folclore, una música propia, una manera de vestir, toda una cultura etnográfica, una antropología. Tenemos nuestro propio sistema legislativo ancestral, dentro de lo que es el Estado español y el Estado francés, un sistema administrativo que viene de la edad media con unas leyes primero no-escritas y después escritas. Nuestro idioma, el euskera, propio de los vascos, tiene sus variantes dialectales pero es el mismo idioma a los dos lados del Pirineo. La Academia de la Lengua Vasca tiene más de cien años de historia y ha ido impulsando el desarrollo del propio idioma. El euskera es una lengua pre-indoeuropea que no tiene relación con ninguna familia de idiomas a nivel mundial, ni con el español, ni con el catalán, ni con el francés, que son lenguas latinas indoeuropeas, pero tampoco con otros idiomas célticos. En la década de los sesenta se produjo un proceso de unificación alfabética y gramatical del idioma, que provocó cierto conflicto en el seno de los vascoparlantes entre los más puristas y quienes podríamos identificar como innovadores modernistas a la búsqueda de un idioma con una raíz común, una estructura gramatical común. El conflicto se superó y hoy el sistema educativo está basado en un modelo unificado de idioma, aunque luego cada uno en nuestra casa utilizemos el dialecto con el que normalmente nos comunicamos. Por otro lado, ha sido necesario un esfuerzo para formar a los profesores del sistema educativo en capacitación para poder enseñar en euskera. Es un proceso muy largo y costoso que estamos abordando con compromiso y confianza.

Es una lengua que estuvo en riesgo de desaparecer como consecuencia de varios factores. Por una parte, a principios del siglo XX, un proceso rápido de industrialización del País Vasco con una afluencia masiva de personas de otras comunidades que hicieron que se impusiera el castellano al euskera. Por otra parte, a lo largo de buena parte del siglo XX, la prohibición expresa por parte del régimen dictatorial franquista del uso de idiomas como el euskera o el catalán. De cara al futuro y debido al fenómeno de la globalización, y particularmente la incidencia de los medios de comunicación, tenemos una preocupación por el bajo hábito en el uso diario del euskera entre los jóvenes. Una reciente encuesta sociolingüística establece que el 60% de los jóvenes menores de 16 años es bilingüe. Sin embargo, el uso del euskera en la calle es más bajo y se ve muy condicionado por el “efecto moda” de los idiomas que se están utilizando permanentemente desde los medios de comunicación.

Nosotros tenemos un especial empeño en conocer cuáles son los idiomas que existen a nivel mundial con la misma o similar problemática a la del euskera, esto es, que se pueden encontrar en declive o en riesgo de desaparición. Tenemos mucho interés por las lenguas habladas en América como el guaraní, las lenguas mayas o incas; así como también una inquietud por la evolución en Europa de lenguas como el gaélico o el talamí en Holanda. Estamos en ese interés de mantener una relación con los pueblos indígenas y las manifestaciones culturales que descienden de pueblos indígenas. Todos los pueblos que sufran algún tipo de imposición o de dictadura son pueblos que gozan del afecto del pueblo vasco. La organización UNESCO cuenta con “casa propia” en Euskadi y aspiramos a tener una representación permanente en Naciones Unidas, como observador en primera instancia. Identificamos la ONU como una organización que tiene que servir como herramienta para lograr que la realidad de cada Pueblo sea respetada. Somos un Pueblo abierto comprometido con mantener y desarrollar nuestras propias señas de identidad en el siglo XXI en que vivimos.

## Creating an Ecosystem for Excellence in Leadership

by Elizabeth Filippouli, Founder & CEO, Global Thinkers Forum

In this day and age our world has paradoxically become smaller in size but unlimited in potential for communication, collaboration and change. Innovation and new technologies are abolishing barriers and borders, while also creating challenges and forcing us towards a major paradigm shift. Today it is imperative that we think from a global perspective and also adapt to the demands of rapidly changing environments. In a world of uncertainty, instability and continuous change, existing thought leadership and ethics are no guarantee for future progress—or even survival. At the heart of the globalisation riddle is the question of how leadership practices have to be renewed, and how ethics and cultural diversity are necessary elements for an ecosystem that nurtures excellence in leadership and good governance.

Governance broadly is one main challenge facing global thought leaders. The interconnected, very large global economy conflicts with governments and international institutions' limited capacity to govern it, creating an asymmetry that leads to failing governance. In 2012 we launched Global Thinkers Forum as a platform to change perceptions about leadership and governance and foster the rethinking of our values for the future. Our world needs global perspectives. We need capable, success-orientated, pioneering minds from the Western world, from the Arab world, from Africa, Asia and Latin America, to join forces for a better world.

In Amman, Jordan, under the patronage of Her Majesty Queen Rania Al Abdullah, Global Thinkers Forum launched a global meeting that gathered 400 delegates from all over the world and celebrated the women leaders of the Middle East and North Africa, as well as the talent, knowledge and potential that exist in Arab societies. In multicultural environments, it is critical that we promote commonalities in order to coexist in peace, and productively. There are various allegiances that pull towards different directions, yet leaders need to provide the intellectual ‘glue’ that holds a multicultural society together. At Global Thinkers Forum (GTF), we believe that in order to achieve a nexus of positive process we need to:

- Help train incumbent and future leaders across all sectors and disciplines to imagine old problems in fresh ways and to bring innovative capacity to recurring challenges
- Encourage the triangle of collaboration between the public sector, the private sector and civil society
- Support and reinforce the Education sector
- Create results-driven projects
- Nurture social innovation via entrepreneurship and other mechanisms

Our mission and duty is to open new communication conduits and build bridges by creating collaboration opportunities that transcend nation states. At GTF we open pathways for young talent to shine. We actively help people realize their dreams. In Amman, we celebrated and admired young Arab entrepreneurs who had the opportunity to pitch to an audience of 300 angel investors, business leaders, international media and global thinkers.



We are humbled by world acclaimed leaders who have warmly embraced Global Thinkers Forum: Her Majesty Queen Rania Al Abdullah, HRH Princess Sumaya bint El Hassan, Arianna Huffington, HE Ambassador Nassir Abdulaziz Al-Nasser, His All-Holiness the Ecumenical Patriarch Bartholomew, Tariq Ramadan, Elif Shafak, Zaha Hadid, Tu Weiming, and many others.

In 2013 our GTF community expanded further; it has added new very important strategic partners such as the UN Alliance of Civilizations, the World Policy Institute, and Professionals for Humanity, to name but a few, who have joined forces with us spearheading a five-year 2014-2018 plan.

I look forward to welcoming you to the Global Thinkers Forum Community: find us on [www.globalthinkersforum.org](http://www.globalthinkersforum.org), and join forces. We can create positive change, locally and globally. Together!





# Globalization and Identity

*Having learned about the trajectory of Basque society from the President of the Nationalist Basque Party and current Lehendakari, CENTERPOINT NOW wondered how individuals from Basque Country outside of the political realm view questions of globalization and identity.*

**Celebrated Basque Musicians, Mikel Markez and Eñaut Elorrieta, who formed a joint project to promote Basque music, shared their views.**



## **How did your collaboration begin?**

**Mikel Markez:** We were united by our passion for music in Euskera and its transmission to future generations. It’s important for an artist to know how to look to the past. I began with different musical references, like Latin American songs, the Anglo-Saxon world, French songs...but my principal reference was always traditional Basque music. Eñaut plays pop rock with a group, but he’s also very connected to our tradition. We came together for this project that combines talks with concerts, initially focusing on reaching young people in Euskadi (Basque country), so they won’t lose contact with the traditional music of our land.

**Eñaut Elorrieta:** The same music that plays on the radio in New York is being listened to in Euskal Herria. The most powerful are those who have the most money to disseminate their music. We are very committed to our culture and language, and we do believe that we must make a double effort, especially in the absence of our own state. Powerful states like Spain and France could help us preserve our language and our culture, but they do the opposite, or do it only in a very secondary way, so we have to do it ourselves.

## **Aside from the language, what distinguishes Basque music?**

**M.M. :** We have traditional instruments like the Txalaparta, horizontal boards that are played in pairs, a diatonic accordion.... instruments that have served throughout history to interpret a traditional repertoire. With time and influences from abroad, these instruments have gathered new repertoire, and today one can see a diatonic accordion, which has always been used for traditional dance, on the stage in a rock group creating something hybrid.

**During your presentation at the Cervantes Institute, you mentioned a song in Euskera that was among the “top 5” in Spain at some point in time. Is it difficult to reach beyond Euskadi and attain a public that doesn’t understand your language?**

## **¿Cómo empezó su colaboración?**

**Mikel Markez:** Nos ha unido la pasión que tenemos sobre la música en euskera y la transmisión a las siguientes generaciones. Es importante para un artista saber mirar atrás. Empecé con diferentes referencias a nivel mundial, como la canción latinoamericana, el mundo anglosajón, la chanson française, pero mi referencia principal siempre han sido los cantantes de las anteriores generaciones nuestras y la canción tradicional. Eñaut hace pop rock con un grupo, pero el también tiene muy presente la tradición. Nos juntamos para este proyecto que combina charlas con conciertos en un principio planteándolo sobre todo en Euskadi, mirando a los jóvenes para que no pierdan el contacto con lo que es la tradición musical de nuestra tierra.

**Eñaut Elorrieta:** Lo mismo que se escucha en Nueva York en la radio y en la televisión también se escucha en Euskal Herria. El mas poderoso es él que mas dinero tiene para difundir su música. Somos gente muy comprometida con nuestra cultura y nuestra lengua y sí creemos que hay que hacer un doble esfuerzo, sobre todo al no tener un estado propio. Los estados potentes como el español y el francés podrían ayudar a preservar nuestra lengua y nuestra cultura, pero hacen todo lo contrario o lo hacen de manera muy secundaria, entonces tenemos que hacerlo nosotros mismos.

## **¿Aparte del idioma, que distingue la música vasca?**

**M.M. :** Tenemos instrumentos tradicionales como la Txalaparta, unas tablas que se ponen en horizontal y se tocan en parejas, un acordeón diatónico...instrumentos que han servido a lo largo de la historia para interpretar un tipo de repertorio tradicional. Con el tiempo y las influencias que vienen de fuera, esos instrumentos han recogido nuevo repertorio y ahora mismo puedes ver en un escenario un acordeón diatónico que ha sido siempre para baile tradicional tocando en un grupo de rock y haciendo una cosa híbrida.

**En su presentación en el Instituto Cervantes mencionaron una canción en euskera que fue “top 5” en España en algún momento. ¿Es difícil proyectar su música fuera de Euskadi y llegar a un público que no entiende su idioma?**

**M.M. :** El 70 % de los españoles tampoco entiende el inglés. Al final hay canciones muy especiales.... El proyecto nos ofreció la posibilidad de ir fuera de Euskadi y presentar a gente que no tiene conocimiento de música en euskera. No se trata solamente de un esfuerzo mirando a los nuestros sino mirando al mundo

**M.M. :** Seventy percent of Spaniards don’t understand English either. At the end of the day there are songs that are very special.... Our project opened up the possibility of going outside of Euskadi and presenting to people who have no knowledge of music in Euskera. It’s not just about reaching our own, but also about looking to the world in general. Our language and culture are among the most ancient of Europe. They are a way of seeing the world; if they were to be lost, it would be like losing a color of the rainbow.

**E.E. :** Melodies are a universal language; it’s a matter of attitude and being open to listen and feel. Music and the sound of language, even if one doesn’t understand the lyrics, transmit a lot of information. It’s necessary to hear beyond what the mind can comprehend; it’s the language of emotions.

**One of the songs you presented speaks about Guernica; how did the history of the Spanish Civil War affect you?**

**E.E. :** The bombardment of Guernica always seemed like something prehistoric to me, and it was 70 years ago. My grandmother was 11 years old when it happened. They had to escape. They lost the war and were very afraid, so they never spoke about the war. It’s a taboo. They suffered repression, torture, death. My father used to tell me how his mother didn’t want him to learn songs in Euskera. Their fear was so deeply embedded. My grandmother would keep the records that were prohibited by the dictatorship under the grass, where the cows ate, and would take them out at Christmas time. It was only when my grandmother was dying that she began to remember, and I started to pay greater attention and become conscious of the fact that, for example, Guernica has no old town. We have to close wounds, but on the basis of memory, justice and respect, not by forgetting—there’s still an effort of remembering that has to happen.

**M.M. :** In my town mass graves continue to be disinterred; it’s not a matter of pointing fingers, but we need to have a truthful narrative of history. Music can help, without a doubt. If Guernica sounded like something ancient to us, then, for the new generations, it must be like the Middle Ages.

**As cultural ambassadors, what influence do the more recent conflicts and the current debate around sovereignty have on your work?**

**E.E. :** Killing is bad on all sides, but states have the legitimacy to do it, creating “good” and “bad” assassins. Even though ETA surrendered its arms, the root of political conflicts remains unresolved; there is a long way to go. We feel that they want to make us Spanish or French, linguistically and culturally. I am fond of and enriched by the Spanish and especially by the French cultures, but I have my own; the one that my parents taught me and that my grandparents taught them.... I believe in the Independence of Euskal Herria, from a linguistic and cultural point of view. Artistic creations, like songs, help to communicate, understand, and build bridges.

**M.M. :** In the songs—and even in the melodies—the situation of conflict is reflected. Now that ETA has laid down its arms, we can have a broader picture of all that has happened. In the end, what remains is the will of the people; the word “self-determination” says it all.



en general. Nuestra lengua y cultura es de las más antiguas de Europa, es una manera de ver el mundo; si la nuestra se perdiera, sería como perder un color del arcoíris.

**E.E. :** Las melodías son un lenguaje universal, es una cuestión de actitud y de estar abiertos a escuchar y a emocionarte. La música en sí y la sonoridad de los idiomas, aunque no comprendas exactamente la letra, te transmitan mucha información. Hay que intentar oír mas allá de lo que puede entender la mente; es el lenguaje de las emociones.

**Una de las canciones que presentaron habla de Guernica; ¿cómo les ha afectado la historia de la guerra civil?**

**E.E. :** El bombardeo de Guernica parece a veces como de la prehistoria, y solo fue hace 76 años, es historia muy reciente de nuestro País. Mi abuela tenía once años cuando tuvo lugar el bombardeo. Tuvieron que escaparse. Perdieron la guerra y tenían mucho miedo, entonces no hablaron de la guerra. Es un tabú. Habían sufrido represión, torturas, muertes. Mi padre me decía que a su madre no le gustaba que aprendiera las canciones en euskera. Ya tenían un miedo muy metido dentro. Mi abuela guardaba los discos prohibidos por la dictadura donde comían las vacas, debajo de la hierba, y se sacaban en Navidades. Cuando mi abuela se estaba muriendo es cuando empezó a recordar y empecé a fijarme de manera más consciente y a darme cuenta que por ejemplo Guernica no tiene parte vieja. Hay que cerrar heridas, pero hay que cerrarlas desde la memoria, la justicia y el respeto, no olvidando—hay una labor todavía de memoria.

**M.M. :** En mi pueblo se siguen desenterrando fosos comunes; no es cuestión de empezar a señalar a tal y a cual, pero hay que hacer un relato de la historia veraz. La música puede ayudar, sin duda. Si para nosotros Guernica nos sonaba como una cosa antigua, para las nuevas generaciones tiene que ser como de la Edad Media.

**¿Como embajadores culturales, qué influencia tienen los conflictos más recientes y el debate actual entorno a la soberanía sobre su trabajo?**

**E.E. :** Matar está mal por todos lados, lo que pasa es que los estados tienen la legitimidad de hacerlo, creando asesinos buenos y asesinos malos. Aunque ETA a dejado las armas, todavía el conflicto político de raíz sigue sin resolverse, queda un largo camino. Sentimos que nos quieren españolizar y afrancesar, lingüística y culturalmente. A mi las culturas española y sobre todo la francesa me encantan y me enriquecen, pero yo tengo la mía, la que me enseñaron mis padres, y a ellos mis abuelos... Yo creo en la independencia de Euskal Herria, desde un punto de vista lingüístico y cultural. Las creaciones artísticas, como la canción, ayudan a difundir, entender y crear puentes.

**M.M. :** En las canciones—en las melodías incluso—se ha reflejado esa situación de conflicto. Ha llegado el momento en el cual ETA ha dejado las armas. Ahora sí tenemos la posibilidad de hacer una fotografía de todo lo que ha pasado. Al final de todo siempre esta la voluntad del pueblo; la palabra “autodeterminación” lo dice todo.

*Photos courtesy of Mikel Markez*

Mikel Markez and Eñaut Elorrieta at the Instituto Cervantes.

www.mikelmarkez.com  
www.kenzazpi.com



*An Appeal for Debate, with Historian*

# Julián Casanova



Photo by: Lucas Torres

Julián Casanova Ph. D, Head of Department of Contemporary History at the University of Zaragoza, is a member of the Editorial Committee of the journal *Historia Social* and of the Advisory Board of *The International Journal of Iberian Studies* (Bradford, England) and *Cuadernos de Historia de España* (Buenos Aires, Argentina). Publications include *The Spanish Republic and Civil War* (Cambridge University Press, Cambridge, 2010); with Carlos Gil, *Historia de España en el siglo XX* (Ariel, Barcelona, 2009, forthcoming at Cambridge University Press; *A Short History of the Spanish Civil War* (I.B. Tauris, 2012).

www.juliancasanova.es

## ***¿Puedes describir la formación de las comunidades autónomas en España después de la muerte de Franco?***

El 20 de noviembre de 1975, la fecha de la muerte de Franco, no había ningún guión escrito, ningún camino fijado de antemano para que una dictadura autoritaria de casi cuatro décadas se convirtiera de manera pacífica en una democracia plena, reconocida por los países de la Europa Occidental. Las cosas evolucionaron de una manera determinada pero pudieron haber sido distintas. El resultado final, por lo menos a partir de 1982, fue una monarquía parlamentaria basada en una Constitución democrática, con un amplio catálogo de derechos y libertades. Muchos acontecimientos en apenas siete años de historia. Definido el marco jurídico, aprobada la Constitución, en los años siguientes se inició el desarrollo del Estado de derecho y la organización territorial autonómica en medio de graves problemas como el involucionismo militar, el terrorismo o la crisis del sistema de partidos. Cuando los socialistas llegaron al poder, después de la victoria arrolladora de octubre de 1982, se podía decir que la transición había concluido y que la democracia caminaba hacia su consolidación.

## ***¿Cómo explicas el deseo de algunas regiones de tener más autonomía que otras?***

Uno de los primeros problemas que tuvo que abordar la nueva democracia española, tras las elecciones de junio de 1977, las primeras elecciones democráticas desde febrero de 1936, y que no admitía más espera, era el de las reivindicaciones autonomistas de los nacionalistas vascos y catalanes. Era imposible olvidar las imágenes de la impresionante manifestación del 11 de septiembre de 1977 en Barcelona, una *díada* con un millón de asistentes.

Los dos primeros estatutos de autonomía, el de Cataluña y el del País Vasco, siguieron caminos paralelos, con muchos puntos en común. Ambos fueron aprobados en el Congreso, después de pasar por duras negociaciones en el seno de una comisión mixta, y recibieron el voto afirmativo de un 90 por cien de los electores que acudieron a las urnas en los referéndums convocados el mismo día, el 25 de octubre de 1979, con una participación muy baja, que apenas llegó al 60 por ciento del censo. Más tardío fue el proceso de tramitación del estatuto gallego, aprobado en el referéndum celebrado en diciembre de 1980.

Mucho más fácil resultó el trabajo para encauzar las demandas de autogobierno que, primero en Galicia y Andalucía, y luego en el resto de las regiones, surgieron a la zaga de las reivindicaciones de los nacionalismos vasco y catalán. Siguiendo la estela de las tres “comunidades históricas” (Cataluña, País Vasco y Galicia), las fuerzas políticas andaluzas consiguieron el acceso a la autonomía por el camino del artículo 151 de la Constitución, en vez de seguir la vía más lenta y restrictiva del artículo 143, como pretendía el Gobierno. Este hecho, sumado a los derechos forales conservados por Navarra y los regímenes especiales acordados para Baleares y Canarias, supuso, en la práctica, la progresiva extensión del

approved in Congress, following arduous negotiations within a mixed committee, and received the affirmative vote of 90% of voters who showed up for the referendum on the 25<sup>th</sup> of October 1979 with a low participation that barely reached 60% of the census. Later on came the process of the Galician statute, which was approved in a referendum in December 1980. The work of channeling the demands for self-governance, first in Galicia and Andalusia, and then in the other regions, was much easier following the vindications of Catalan and Basque nationalism. Based on the three “historic communities” (Catalonia, Basque Country, and Galicia), Andalusia’s political forces achieved autonomy through article 151 of the Constitution, rather than via the slower and more restrictive path of article 143, as the government would have desired. This fact, added to local government rights conserved by Navarra and the special administrations in Baleares and Canarias, implied, in practice, the progressive extension of the maximum level of competencies accorded by the Constitution to all of the regions. The Spanish autonomous map was completed in the first months of 1983 with the promulgation of the four pending autonomy statutes of the previous legislature. The said “coffee for all” generated an obvious unease among those who defended historic specificity as a superior degree of competency, and among the forces of the left that warned about the slow loss of space available to an orthodox federal project. They were not entirely wrong. The extension across Spain of pre-autonomous organisms determined the limits of the debate over the territorial restructuring of the state that had to be confronted in the constituent process. What came to light in the past years is precisely the Catalan and Basque unease with the “coffee for all.” However, what for three decades was an aspiration for greater autonomy has now become a clear push for independence.

## ***The principle of self-determination is a right supported in theory by all UN Member States. Do you believe that Spain’s response to the movements for independence is adequate? If not, what would you advise?***

The generalization of the statutes of autonomy to all of the communities was the response of the State and key political forces to the political and administrative decentralization, one of the pending tasks of the process of consolidating democracy; and to the articulation of a concept of Spain that would be compatible with the more nationalist political and cultural identity of Catalonia and of the Basque Country. This worked relatively well until the economic crisis and the disputes surrounding the status of Catalonia created an irrespirable atmosphere. Those who were pro-independence converted their particular idea of Spain into the scapegoat for all ills and disappointments that emerged as a consequence of the crises. Catalonia is neither subjected to a pillaging on the part of Spain, nor do the majority of Spaniards harbor feelings of disdain towards Catalonia. What I defend, as do other intellectuals who aim to have a presence in civil society, is an improved institutional settlement for Catalonia (revising what the process of constructing the autonomies has left obsolete) and a federal alternative to the deteriorated State of the autonomies. This is the path, along with revising the Constitution of 1978 with great accords if they are necessary. The problem is that in Spain, in the past years, uproar and argument have take precedence over knowledge and debate.

## ***These issues appear to be extremely divisive and visceral. Are there efforts to engage civil society in dialogue or understanding different positions?***

No, and hence one of the greatest problems. A great abyss has been opened between the majority of the political class and a good part of the population, which considers the former to be a caste that practices favoritism and corruption. Debate has given way to yelling. The tradition, which, since the Enlightenment, was represented by good debates (persuasion, strong arguments), has been lost. In Spain, politicians and journalists in general tend to be prepositioned, rooted in their territory without listening to the other. Or, in other words, regardless of what the other says,

nivel máximo de competencias previsto por la Constitución a todas las regiones. El mapa autonómico español se completó en los primeros meses de 1983 con la promulgación de los cuatro estatutos de autonomía pendientes de la legislatura anterior.

El llamado *café* para todos generó un malestar evidente entre quienes defendían la especificidad histórica como un techo superior de competencias y entre las fuerzas de la izquierda que advertían cómo poco a poco perdía espacio un proyecto federal más ortodoxo. No les faltaba cierta razón. La extensión por toda España de los organismos preautonómicos perfilaba los límites del debate sobre la reestructuración territorial del Estado que debía afrontarse en el proceso constituyente.

Lo que ha salido a la luz en los últimos años es precisamente ese malestar catalán y vasco por el “café para todos.” Pero lo que era hace tres décadas una aspiración de mayor autonomía, se ha convertido ahora en una clara apuesta por la independencia.

## ***El principio de la autodeterminación es un derecho apoyado, en teoría, por todos los estados miembros de la ONU. ¿Consideras que la respuesta de España a los movimientos independentistas es adecuada? ¿Qué aconsejarías?***

La generalización de los estatutos de autonomía a todas las comunidades fue la respuesta del Estado y de las fuerzas políticas más importantes a la descentralización política y administrativa, una de las tareas pendientes del proceso de consolidación de la democracia; y a la articulación de una concepción/idea de España compatible con la identidad más nacionalista, política y cultural, de Cataluña y del País Vasco.

Eso funcionó bastante bien, hasta que la crisis económica y las disputas en torno al Estatuto de Cataluña crearon una atmósfera irrespirable. Los independentistas convierten su particular idea de España en el chivo expiatorio sobre el que cargar todos los males, desencantos y malestares como consecuencia de las crisis. Ni Cataluña está sometida a un expolio por parte de España, ni el común de los españoles alberga sentimiento alguno de menosprecio hacia ella.

Lo que yo defiendo, como otros intelectuales que tratan de tener presencia en la sociedad civil, es un mejor ajuste institucional para Cataluña (revisando lo que el proceso de construcción de las autonomías ha dejado obsoleto) y una alternativa federal al deteriorado Estado de las autonomías. Ése es el camino y revisar la Constitución de 1978, con grandes acuerdos, si hace falta. El problema es que en España, en los últimos años, la bronca y la disputa se han impuesto al conocimiento y al debate.

## ***Esos temas parecen muy divisivos y viscerales. ¿Hay esfuerzos de involucrar a la sociedad civil en un diálogo o entendimiento de diferentes posiciones?***

No y de ahí uno de los grandes problemas. Se ha abierto un gran abismo entre la mayor parte de la clase política y una buena parte de la población, que considera a esa una casta que practica el amiguismo y la corrupción. El debate ha dado paso al grito. Se ha perdido la tradición de lo que, desde la Ilustración, han representado los buenos debates: argumentar, persuadir, tratar de convencer con argumentos al contrario.... En España, los políticos y periodistas, en general, suelen estar ya posicionados, afincados en su territorio, y no escuchan al otro. O, en otras palabras, independientemente de lo que diga el otro, cada uno ya sabe lo que va a decir y defender: lo suyo. Hay que recuperar el valor de la educación, del respeto y esto tiene que empezar por quienes más medios tienen: políticos, periodistas, empresarios, profesores.... Sin esa vuelta a los valores de la educación y del debate, no hay salida.



# COMUNIDADES AUTÓNOMAS DE ESPAÑA



each one already knows what he will say and defend: his own position. We have to recover the value of education and respect, and this must begin with those who have the means: politicians, journalists, businessmen, professors.... Without returning to the values of education and debate, there is no way out.

### *It's common to hear expressions of disillusion with the European Union. Is the EU "sustainable?" How do you envision its future?*

At the start of the 21<sup>st</sup> Century, Spain was a modern and developed country, unknown to any observer that would have spent decades outside of its borders. The European dream was fulfilled, and society left behind some of the historic problems that preoccupied it in the past. But it still inherited old unresolved conflicts, such as that of the territorial organization of the State, or the survival of terrorism and new challenges such as the phenomenon of immigration or the consequences of globalization. All of these problems appeared with severity in the past five years, spurred on by the crisis despite the end of terrorism. Suddenly, everything is going wrong. Nothing from the past has any value, and the dream of belonging to Europe that Spaniards achieved in 1986 is now almost broken, when people perceive that many of the ills we are experiencing (along with the Italians, Portuguese, Irish, or Greeks) derive from the imposition of a harsh settlement by the center of capitalist Europe, represented today by Germany. The idea of Europe is in danger, and is no longer as attractive in the countries of the East that emerged from communism in the 90s with the dream of integrating into Europe, and is also being questioned in Mediterranean countries. Democracy appears more fragile than ever, compared to the perception that it was eternally consolidated, as was propagated at the end of the 20<sup>th</sup> Century, following the fall of the Soviet Block. We have to strengthen democracy in the face of authoritarian right wing movements and the irresponsibility of many politicians, and push once again for solidarity and a just distribution of wealth rather than establishing clear differences between a rich Europe and another peripheral and poor (or less rich) Europe.

### *Es común escuchar expresiones de desilusión respecto a la Unión Europea. ¿Crees que la UE es "sostenible?" ¿Cómo ves su futuro?*

Al comenzar el siglo XXI España era un país moderno y desarrollado, desconocido para cualquier observador que llevara varias décadas fuera de sus fronteras. El sueño europeo de los escritores regeneracionistas se había cumplido y la sociedad había dejado atrás algunos de los problemas históricos que más la habían preocupado en el pasado. Pero también heredaba conflictos antiguos aún no resueltos, como el de la organización territorial del Estado o la pervivencia del terrorismo, y retos nuevos como el fenómeno de la inmigración o las consecuencias del proceso mundial de globalización.

Todos esos problemas han aparecido con crudeza en los últimos cinco años, espoleados por la crisis, pese al final del terrorismo. De repente, o casi de repente, todo va mal, nada de lo anterior vale y el sueño regeneracionista e ilustrado de pertenecer a Europa, que los españoles logramos en 1986, está ahora en entredicho, casi quebrado, cuando la gente percibe que una buena parte de los males que tenemos (pero también los italianos, portugueses, irlandeses o griegos) deriva de la imposición de un duro ajuste por el centro del capitalismo europeo, representado ahora por Alemania.

La idea de Europa está en peligro, ya no resulta tan atractiva en los países del Este, que salieron del comunismo en los años noventa con el sueño de integrarse en ella, y está siendo cuestionada en los países mediterráneos. La democracia parece más frágil que nunca, frente a la idea que la veía casi eterna y consolidada para siempre, como se propagó a finales del siglo XX, tras la caída del bloque soviético. Hay que fortalecer la democracia, frente a movimientos autoritarios de derechas y la irresponsabilidad de muchos políticos, y apostar de nuevo por la solidaridad y justa distribución de la riqueza, en vez de por asentar claras diferencias entre una Europa rica y otra periférica y pobre (o menos rica).

Map by Karla Saldaña



# Green Growth for the Baltic Sea by Katharina Brecht with Sten Björk

It is essential to safeguard and protect the oceans, rivers and all water resources of this planet. They can no longer be allowed to be dumping grounds for chemicals, waste, and pollution. The destruction of water resources worldwide is a threat to human survival, as well as to marine life and to industry, so sustainable infrastructure must be put in place by all countries and sectors in order to truly make a difference.

In the Baltic Sea region, which is confronted with the increasing challenge of ships routinely pumping waste and fecal matter into the sea and generating enormous pollution, innovative collaboration is already underway. The Baltic Sea area is particularly vulnerable, as it is a flat, semi-enclosed sea, which is very congested by shipping and where pollution can't be easily distributed. To address this problem, the non-governmental organization, Baltic Sea Forum, is bringing together representatives of nations, cities, individuals, business and industry, health systems and environmental organizations to identify solutions, alleviate the eutrophication of the Baltic Sea, and reduce the emission of gases from ships and water pollution.

I invited Mr. Sten Björk, political environmental strategist at the Port of Trelleborg, in Sweden, and lead partner for the European Union Clean Baltic Sea Shipping project, to comment on the background and methodology of CLEANSHIP, one of the efforts that is already yielding positive results in waste management and effective international multi-stakeholder partnerships.

### *What is the background and how would you define the purpose of "CLEANSHIP?"*

Shipping forms a major backbone of the growing trade in the Baltic Sea region, reflecting and contributing to the prosperity of the region. However, shipping also contributes to the severe eutrophication of the Baltic Sea through air and water pollution. CLEANSHIP is a flagship project for the EU Baltic Sea Strategy. At the core of CLEANSHIP are: 1. the joint elaboration of a clean shipping strategy; 2. the preparation of pilot activities, including supporting analyses; and, 3. the harmonization and standardization of environment-related infrastructure. CLEANSHIP will reduce ship-borne air pollution at sea, in ports and in the port cities, as well as reduce nutrient inputs from ships to the sea towards a zero-level. It will create a joint strategy for differentiated



port dues and create pilot projects in full scale as best practice examples. It will also take into account the interrelated goals of all stakeholders.

### *What has been achieved so far?*

There is a rapid development by partners of CLEANSHIP creating possible solutions for existing ships to convert their main propulsion and auxiliary engine systems to fulfill the new Sulphur Emission Control Area (SECA) directives in the Baltic Sea region. The Port of Trelleborg already started to organize the Bio-CNG (compressed natural gas) logistics of transport from a biogas plant to port vehicles. The Port of Klaipeda is elaborating on how local small-scale LNG (liquefied natural gas) logistics to ships at docks in the port can be organized from a large LNG import terminal. The Port of Rostock has started a feasibility study of an LNG terminal for the fuelling of ferries and large-scale cruise ships. The Ports of Stockholm are developing an Environmental Port Index accompanied by differentiated port dues. The Port of Oslo, in close cooperation with the Norwegian ferry service, Color Line, are elaborating a pilot case of how shore-side electricity could be established for large vessels with their huge power demand so that ships can stop all their auxiliary engines when in port.

### *What are the goals for the next five years?*

The major goals for the near future include a complete nutrient balance in our part of the Baltic Sea; being completely independent of fossil fuels; and achieving a nutrient circulation in agriculture. One solution that has been adopted is to pump the waste tank from the ships into big fluid reservoirs and use that waste to generate biogas as an energy source. We want to reach a large-scale production of biogas and ensure "green maritime traffic," "green urban areas," and "green industry." To this end, we are focused on collaboration among all coastal regions surrounding the Baltic Sea and the parallel measures to be realized in all Helsinki Commission (HELCOM) countries. The Baltic Sea has to be considered a common resource and so it's essential to have a comprehensive view and integrate efforts between authorities and agencies, both within countries and among them, always seeking win-win strategies.

Photo, left: Ships in the Port of Trelleborg; right: Swimming in the Port of Oslo.

Katharina Brecht is the Main Representative to the United Nations for the Baltic Sea Forum.

[www.baltic-sea-forum.org](http://www.baltic-sea-forum.org)



# The EU and Turkish Cypriots: Development Without Democracy?

by Lucia Najšlová

**The absence of foreign policy consensus among the European Union’s members has, in many instances, positioned the EU as a payer, rather than a player. Where there is diplomatic standstill, the political aspects of development are ignored in favor of technical assistance. This is particularly disconcerting in Northern Cyprus, inhabited by the Union’s ‘own’ citizens, the Turkish Cypriots.**

The Republic of Cyprus was established in 1960 as a common state of Greek and Turkish Cypriots on a small island in the Eastern Mediterranean. The complicated power-sharing arrangements did not work though, and the Greek Cypriot proposal to relegate Turkish Cypriots to the status of minority, as opposed to that of a constitutive community, resulted in intercommunal violence and a de-facto partition in 1963. A UN peacekeeping force has been stationed on the island since 1964, yet it could not prevent further escalation of the conflict. The partition was solidified by Turkey’s 1974 military intervention in the wake of Greek junta plans to annex the island to Greece and threats to decimate Turkish Cypriots.

An ethnically Greek south and Turkish north emerged, with hundreds of thousands of refugees and abandoned property. Until 2003 the UN patrolled Green Line was closed, and the Turkish and Greek Cypriots developed as separate polities with different narratives of the conflict.

International talks on the island’s reunification have been held on and off since the 1960s. In the process, the Southern part of

Cyprus enjoyed international recognition, while the North could claim its existence in international politics only via a ‘community leader,’ a Turkish Cypriot representative who participated in UN-sponsored peace-talks. The governance structure established by Turkish Cypriots—Turkish Republic of Northern Cyprus (TRNC)—was condemned as illegal in a number of UN resolutions, and until today is formally recognized only by Turkey.

Turkey at the same time is Northern Cyprus’ main door for outreach to the wider international community. Until 1994 Turkish Cypriots could more or less freely trade with the EU, their natural market. That year the European Court of Justice resolved that such trade was illegal, and since then the North has become even more dependent on Turkey.

In the 1990s the Greek Cypriot-governed Republic of Cyprus expressed interest in becoming a member of the EU. The EU accepted the application, conveying its belief that the EU integration process could facilitate the peace talks. In parallel to the EU accession process, works continued under the auspices of the UN on the most comprehensive reunification proposal to date—the Annan plan. Yet the referenda held in Cyprus’ North and South shortly before its envisaged EU membership brought results, for which no one seemed to have been prepared. While three out of four Greek Cypriots voted against the peace plan, two thirds of Turkish Cypriots accepted it.

Thus, on May 1, 2004 Cyprus entered the EU as a divided country, with the North being formally a territory of the EU, yet one where EU law was suspended until reunification. For almost 10 years now, the Turkish Cypriots have lived in limbo—formally considered EU citizens, yet deprived of many of their citizenship rights, importantly those pertaining to political representation.

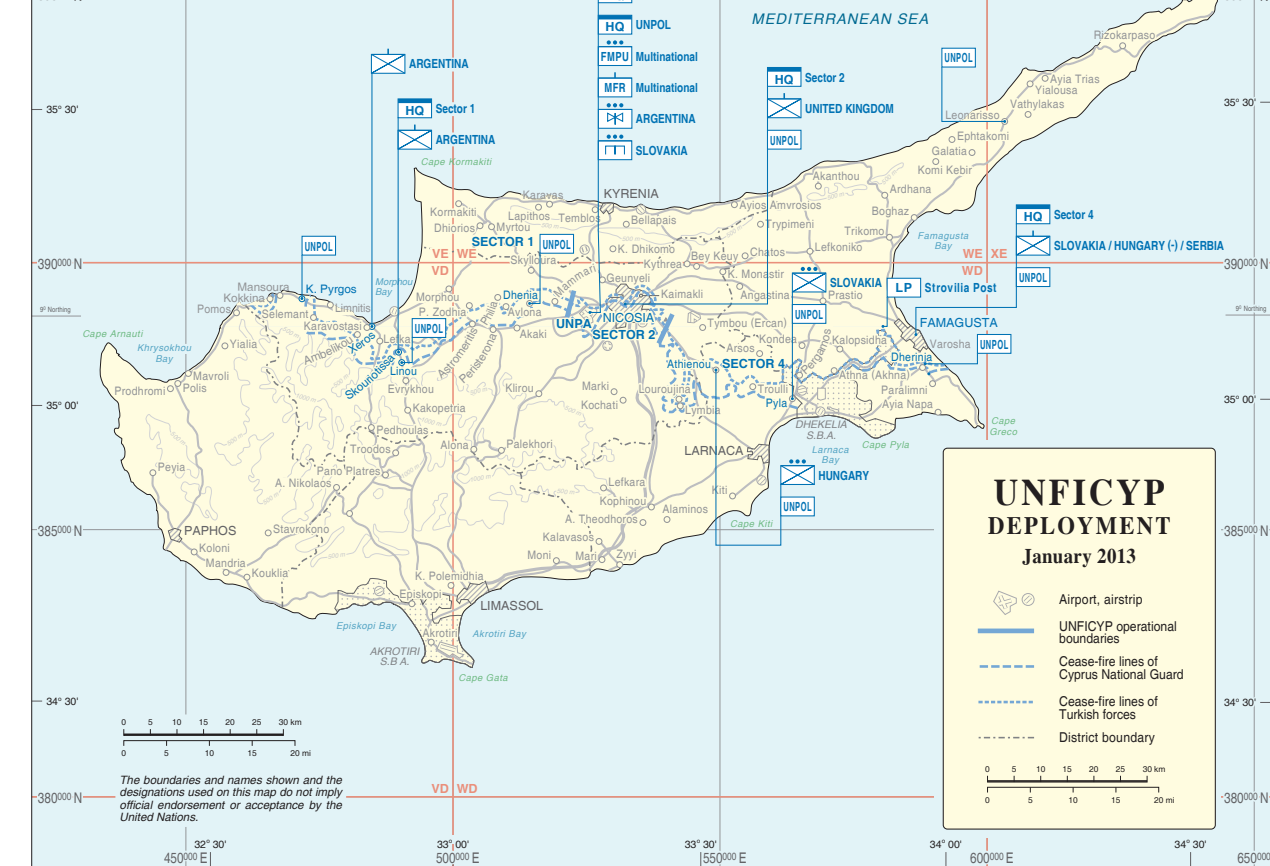

Right after the Turkish Cypriot ‘yes’ vote, the EU pledged to end their international isolation; the European Commission proposed to provide aid to Northern Cyprus and once again enable direct trade. But only part of the pledge came to fruition, and Turkish Cypriots can trade only via the Green Line. In addition to extra costs associated with trading via the South, years of conflict and separate narratives have generated reluctance among Greek Cypriots to advertise Turkish Cypriot products or display them in shops. A 2004 proposed regulation by the European Commission that would have enabled direct trade (not via the South) was strictly opposed by a number of EU politicians, including Greek Cypriots who would stand to benefit from the economic development of the North.

A workable plan for the island’s reunification has yet to be formulated, so the only thing the North can receive is aid. Since 2006 the European Union has disbursed resources to ‘bring the Turkish Cypriots closer to EU,’ paying for commendable activities such as infrastructure projects, scholarships for students, and support for NGOs. Acknowledging that Northern Cyprus’ eventual full integration into the EU includes the harmonization of its laws with EU *acquis*, the EU aid also pays for study trips of representatives of the Turkish Cypriot administration to EU member states’ public institutions. Yet, in the process of aid provision, the EU can do little to strengthen Northern Cyprus’ democracy, since it can only engage with Turkish Cypriot ‘experts’ or ‘stakeholders,’ but not with ministers or parliamentarians. Until the Cyprus conflict is resolved, Turkish Cypriots do not have the internationally endorsed right to democratic representation.

Speaking about democracy in Northern Cyprus, one easily runs into criticism suggesting that recognizing Turkish Cypriots’ political rights would only cement the status quo and further impede a resolution of the Cyprus conflict. In other words,

recognition of a Turkish Cypriot right to elect representatives and dispatch them to international fora, critics argue, would imply recognition of TRNC and its jurisdiction over the territory, which, as a consequence of military intervention, hosts about 40,000 Turkish troops and a pool of property owned by the Greek Cypriots.

It seems then that Turkish Cypriots are hostages of the Cyprus conflict. The international community has decided to wait and see. The EU reiterates that it supports the UN-sponsored peace talks, and that it is up to both sides to find a solution. In the meantime, there are no time limits set, and no plan B. Although they are EU citizens, Turkish Cypriots cannot vote in EU institutions and even their local elections are considered illegitimate. The EU, Turkey and various UN agencies carry out projects in Northern Cyprus, many of them laudable, yet there is no mechanism by which Turkish Cypriots can hold these donors accountable.

Observing the international paralysis over Cyprus leads one to wonder if the status quo is convenient, or if the Turkish Cypriots—at about 200,000 people—are too small to matter, and their rights, therefore, are less significant than the interests of the states and individual leaders engaged in the conflict.

Map courtesy of the United Nations/ UNFICYP, Map No. 2930 Rev.80E, January 2013.

[1] See e.g. Hatay, M.; Mullen, F. and Kalimeri, J. (2008). Intra-island Trade in Cyprus: Obstacles, Oppositions and Psychological Barriers. Nicosia: PRIO Cyprus Centre.; Gokcekus, O.; Henson, J.; Nottebaum, D. and Wanis-St John, A. (2012). Impediments to trade across the Green Line in Cyprus: Classic Barriers and Mistrust. *Journal of Peace Research* 49(6): 863-872.

Lucia Najšlová is a Senior Fellow at EUROPEUM Institute for European Policy and Research Fellow at Charles University in Prague. najšlova@fsv.cuni.cz



# Art After Technology

with Maurice Benayoun



**“Technology doesn't yield truth, it brings about questions.”**

We're in a period where we have begun to assimilate technologies and to go beyond them. Technology has an impact on our daily existence as a whole, as well as on art that is not necessarily technological in nature—for example the quest for the 'low-tech,' the desire of certain artists to testify to their ability to create works of art without technology. In going beyond technology, there is the will to understand how it plays a catalyzing role in our way of understanding and interpreting the world.

I have worked extensively on the concept of *Art after technology*. I became interested in virtual reality at a time when everyone was saying that it was something dangerous that was going to distract individuals from the reality of the world in which they live. That was not my intention at all. What interested me was to create *situations* that helped reveal aspects of the world that were not completely transparent. I had the good fortune to be surrounded by very high-level engineers who invented the tools that were necessary for the projects I wanted to realize. We can't do anything complex that would be totally gratuitous, without stakes—clearly the work must speak of something other than formal questions.

With *World Skin* in 1997, we created a photo safari of countries at war—the visitors find themselves in a tri-dimensional landscape populated by images from the Second World War and the war in Bosnia. Immersed in the virtual, the visitors have cameras. Before they enter, we've told them, “you're tourists, take photos.” When they take a photo, what they photograph is erased from the screen and is printed, but the silhouettes, the phantoms, remain. By taking images, they erase the surface of things, “the world skin,” as though they were trying to erase memory, the traces, and appropriate them by obtaining a printed form, an object they can

“La technologie n'apporte pas de vérité en soi, elle apporte surtout des questions.”

Nous entrons dans une période où on commence à avoir assimilé les technologies et à les dépasser. Les technologies ont clairement un impact sur l'ensemble du quotidien, mais aussi sur l'art, même quand il n'est pas technologique—par exemple, la recherche du *low-tech*, la volonté pour certains artistes de témoigner du fait qu'ils sont capables de produire des oeuvres sans technologie. Dans le dépassement des technologies, il y a la volonté de comprendre comment les technologies jouent un rôle de catalyseur dans notre façon de comprendre et d'interpréter le monde.

J'ai beaucoup travaillé sur le concept de *l'Art après la technologie*. Je me suis intéressé à la réalité virtuelle à l'époque où tout le monde se disait que c'était quelque chose de dangereux qui allait distraire les individus de la réalité du monde dans lequel ils vivent. Ce n'était pas du tout mon intention. Ce qui m'intéressait, c'était de créer des *situations* qui permettent de révéler des aspects du monde qui n'étaient pas totalement transparents. J'ai eu la chance d'être entouré d'ingénieurs de très haut niveau qui ont inventé les outils nécessaires aux projets que je voulais réaliser. On ne peut pas faire de chose complexe qui serait totalement “gratuite,” sans enjeu—clairement, l'œuvre doit parler d'autre chose que d'enjeux formels.

Avec *World Skin* en 1997, nous avons créé un *safari photo aux pays de la guerre*—les visiteurs se retrouvent dans un paysage tridimensionnel peuplé d'images de la deuxième guerre mondiale et de la guerre de Bosnie. Immérgés dans le virtuel, les visiteurs ont des appareils photo. Avant d'entrer, on leur a dit, “vous êtes des touristes, prenez des photos.” Quand ils prennent une photo, ce qu'ils prennent en photo est effacé de la scène et sort sur imprimante, mais il reste les silhouettes, les fantômes. En prenant des images, ils effacent la surface des choses, la “peau du monde” (the world skin), comme s'ils essayaient d'effacer la mémoire, les traces, et de se les approprier en obtenant une forme imprimée, un objet qu'ils peuvent emporter avec eux, qui leur appartient. On a l'impression que le geste est innocent au départ quand on fait des photographies, mais finalement il y a un jeu ambiguë avec la mémoire, l'appropriation, l'effacement des traces.

Le problème que j'avais avec la réalité virtuelle, c'est que je mettais les gens à l'intérieur de la représentation, de la fiction. Alors j'ai commencé à travailler sur le concept opposé, sur l'idée de mettre dans l'espace réel, l'espace physique des éléments de questionnement, ce que j'appelle *Critical Fusion* (« fusion critique » de la fiction et de la réalité). Avec *Occupy Wall Screens*, j'aimerais promouvoir l'idée qu'on occupe les terrains des médias avec d'autres formes dans la durée, parce que la fragilité du mouvement “Occupy” est réelle. La série sur “la Mécanique des émotions” met en jeu l'idée que les émotions du monde puissent être une matière susceptible d'être négociée et évaluée, que le cours des émotions du monde fonctionnerait comme le cours de la bourse et que cette valeur d'échange peut faire son chemin comme les valeurs boursières. *Emotion Forecast* et *Occupy Wall Screens* sont dans le monde réel, liés à des données objectives et néanmoins contribuent à se poser des questions sur nos échelles valeurs. Les technologies sont créées par les humains pour les humains; l'économie tient aux échanges



take home...that belongs to them. One has the impression that the gesture of taking photos is innocent, but ultimately there is an ambiguous play on memory, on appropriation, and the erasure of traces.

The problem that I had with virtual reality was that I was *putting people inside of the representation, inside the fiction*. So I started to work on the opposite concept, on the idea of putting elements of questioning into real space, physical space, which is what I call *Critical Fusion* (“critical fusion” of fiction and reality). With *Occupy Wall Screens*, I'd like to promote the idea of occupying the space of media with other forms over time, because the fragility of the “Occupy” movement is real. The series on “the Mechanics of emotions” poses the idea that the emotions of the world can be a product subject to negotiation and evaluation, that the course of the world's emotions could function like the stock market and that this value of exchange could fluctuate like stocks. *Emotion Forecast* and *Occupy Wall Screens* are in the real world, linked to objective data and nonetheless should contribute to questioning our values system. Technologies are created by humans for humans; the economy refers to exchanges between humans. Through my creative work, I am advocating for an improvement of human relations, (H2H, Human to Human interactions) and an economy that puts the human factor at the center (Human centered economics).

The Earth breathes through individuals' emotions. In some ways technology doesn't yield truth, it brings about questions.



entre humains. Par mon travail de création je milite pour une amélioration des relations entre humains, (H2H, Human to Human interactions) et une économie centrée sur le facteur humain (Human centered economics).

La terre respire au travers des émotions des individus. D'une certaine manière la technologie n'apporte pas de vérité en soi, elle apporte surtout des questions.

*Photos of World Skin and participants courtesy of the artist.*

Maurice Benayoun (aka MoBen) is an artist and professor at the School of Creative Media, City University of Hong Kong.

[www.benayoun.com](http://www.benayoun.com)



# Behind the Barriers

*A Conversation with the author of I SHALL NOT HATE,  
Dr. Izzeldin Abuelaish, MD MPH*

**What motivates you to continue your work despite the traumatic loss and obstacles you have experienced?**

If you choose to drown in hate, hatred carries health consequences and makes the world paralyzed. By writing *I Shall Not Hate*, I was able to have a positive impact on people's lives and on my own life. It was a way to heal and move forward. It made me more determined and gave me an even greater sense of responsibility to make a difference. Being a role model is about being resilient and jumping forward, not to attack, but to change the situation. Everything is political. How can we use politics to serve humanity, to help people live a decent life? Life is a school. My experience living through war, poverty, intimidation and humiliation, immunized

me and enabled me to always learn more. Most people take news for granted and are easily misinformed because of ignorance. In a world endemic with violence, hatred, fear, disease, poverty and inequity—all of which cross barriers—why not take precautions? When we see walls dividing people in any part of the world, we need to ask why we are building them, and we need to ask not once, but five times, "What is behind these walls and barriers? What is on the other side? Do I need to protect myself from my neighbor?" Walls are a way of escaping responsibility. Behind the barriers there are people who deserve life and freedom. Barriers don't give peace, security or safety. Disease and violence cross borders; we need to immunize and prevent disease.



It's time to be courageous and take responsibility. We need the psychological imagination to start the change. I can't blame you; I have to first reconcile with myself and get rid of my poison. Before I can communicate with the other, I have to be cleared of my own negative thoughts. We are blessed to have minds that can reflect on a sense of purpose. Why are we here? There is a mission. People are so consumed with how much they have and want, they enjoy their life, but there is often no impact, and little mental and spiritual peace of mind. We were created to know each other, to know the core of the person, to understand without talking. We lost that when we became "individuals." As the world is becoming smaller, we are also becoming self-limited and suspicious.

**Speaking of knowing one another, it is difficult to reflect on the fact that your three daughters, who had gone to peace camp, were then killed by the 2009 Israeli attacks on Gaza.**

Peace camps can help somewhat, but we need to be honest about why we establish them and evaluate their effectiveness. If we succeed in changing situations, then they are meaningful, but if they prolong the situation, there is a problem. These grassroots efforts are seeds, but you need political will to make anything happen. Small sporadic efforts can stimulate political will, but what is needed is a loud voice built on transparency, justice and valuing human life, not taking one side or the other, not branding one side or the other. Palestinian children live a different life than the Israeli children. They get to know each other at peace camp, and then the Palestinian children go back to a situation of intimidation and humiliation, whereas the Israeli children return to their normal life. It's injustice. When we equalize the occupier and the occupied, it's injustice. We need these kids to go back to their government and do something, not to come just to socialize. Everything starts by socializing, but in the end, how can you translate this socializing into political change?

**You have created a foundation in honor of your daughters, Daughters for Life, to support scholarships for women's education. How do you communicate your message to people who resist women's equality?**

The world is built on men and women. I have to convince people because I care. We are all in debt to our mothers, daughters and sisters. To those who resist women's education, I ask, "Who's taking care of the community? The woman is the school; if this school is well-equipped, the students will be great students." Through enlightenment, we can overcome stereotypes and misinformation. Education is critical for all. The ego of men creates fear inside them that women are threatening. We need to educate men to support the education of women and ensure more women are at the table.

**What does "sustainable development" mean to you?**

Sustainability is to change the environment, to change the situation for the better. You can only talk about sustainability once you've achieved something good that you want to maintain. Before sustainability, we must get rid of the causes of suffering. I encourage people to look around, ask and learn. The most precious thing in the universe is freedom. I say to the world, "You are not free as long as anyone else is not free." You can't build your freedom by denying mine, in particular when we come to the Gaza strip, a small piece of land, 40 km long, by 9 km wide, with 1.7 million people, 50% of whom are children under the age of 15.



It's the children and women who pay the price of any suffering in the world. If you were deprived of freedom, locked inside your room without electricity, without vital needs, how would you behave? If you were to lose your mind, would it be your fault? If you started to knock loudly at the door, people would say you are noisy, because they're not inside that room living your life. Open my door and I will never lose my mind. We must want the same justice for others that we want for ourselves.

**What are your next steps?**

*I Shall Not Hate* has been translated into 20 languages. It was made into a play in Israel and will now be performed in Germany as well. It's a blessing and I can say that my daughters are in a sense being kept alive, not to foster hatred, but to help others become aware. I was selected as one of Canada's top 25 immigrants and have had the opportunity to speak before Congress, at the European Union, and to lecture frequently at schools. Children understand the message, but we need to get through to the parents as well.

Photo opposite page:  
Dr. Abuelaish's daughters Mayar,  
Aya, and Bessan, courtesy of Dr.  
Izzeldin Abuelaish, MD MPH

Dr. Izzeldin Abuelaish MD, MPH  
is Associate Professor of Global  
Health at the University of Toronto  
Dalla Lana School of Public Health.

[www.daughtersforlife.com](http://www.daughtersforlife.com)



# Into Sunlight: *Sustaining Movements for Peace*

by Rhea Lehman, PhD

Sustainable development requires peace. We know too well how war's devastation flows far beyond the actual grounds of conflict; how war's individual, social and environmental traumas erupt across geography and history in repetitive patterns. So how, we perpetually ask, can we establish new grounds for healing, reconciliation and lasting peace?

Reconciliation and healing are prerequisites for peace. They are performative acts of grace. As such, they may require imagination, aesthetics, and embodiment. The arts call us to presence, and can awaken us through our heightened senses to recognition, connection, and imaginative empathy. *Into Sunlight*, a performance by Robin Becker Dance, uniquely demonstrates this potential of art to evoke our keen attention and thus our capacity to bear witness to all of life—including war's anguishing and all that our dissociated state otherwise allows us to deny about the underlying unity of life.

Artistic Director and choreographer Robin Becker describes her creative impetus for *Into Sunlight*:

"Throughout my life I have believed in dance as a powerful tool for transformation, providing a context in which we may discover our shared humanity through the moving, sensing body. Deeply saddened when the US went into Iraq, and with a hope of contributing to healing, I embarked upon an evening-length dance that dealt with war, peace and protest in our time. My initial research was to investigate images and mythologies from world cultures to find archetypes that would offer insight into the human activity of war. I discovered *They Marched Into Sunlight*, a book on the Vietnam era by Pulitzer-Prize winning journalist David Maraniss, that documented a battle in Vietnam, a student protest at UW Madison, and the conversations and decisions made behind closed doors between the President and his Cabinet, all on the same two days in October of 1967. Because of strong parallels between our era and the Vietnam era, I chose to use this book as inspiration for my dance. My intention was to express the similarity of integrity, honor and commitment between those who fought the war and those who fought against the war."

The book's inclusive perspective constitutes one aspect of the dance's integrative effect. Maraniss' expansive embrace reaches us directly as his text is re-imagined and rendered choreographically alive. However, *Into Sunlight* is not a literal retelling

of the story; rather, the powerful images documented in the book offered fertile ground for unfolding choreography. Sarah Hazlick's *Washington Post* review of *Into Sunlight* illustrates this potent layering of image and choreography:

"Many parts of *Into Sunlight* give the audience room to fill in the details. In the penultimate section, "Longing," one of the male dancers in gray sits immobile and straight-backed on the floor. Another dancer, Yoko Sugimoto-Ikezawa, throws her arms around him tightly, an image that looks almost like she could be clutching a tombstone. But as she continues, touching his steely face, sitting in his lap and finally lying beside him, different but equally wrenching stories unspool: Maybe she is a woman watching a loved one die, or maybe she's trying to connect with a withdrawn man who's coping with post-traumatic stress disorder. It's that kind of layered composition that probably allows any veteran to see a piece of himself or his experiences in this work." (Jan 22, 2013)

The review reminds us that dance creates not only a visual and aural experience, but a kinesthetic one as well. The body is the seat of our shared humanity, and movement is our primary language. As an expression through this universal language, dance has the unique capacity to generate a deeply felt experience of healing. In speaking of her choreographic process, Becker describes one section of the dance, called "Letters." She also introduces her approach to the element of performance:

"I experimented with couples passing a piece of paper back and forth across the stage space, symbolizing all the letters that crossed the ocean. Men and women were writing home from the war about their fears of killing, being killed, their relationships, their children, and often their depression and longing for home. In this section, I wanted to capture the potency of the time of waiting. I saw the space as an active participant in the dance. The shaping of negative and positive space was as significant to me as sculpting the bodies. I wanted viewers to be able to participate and enter into the experience on stage, instead of having a message 'delivered' to them by the performance. I ask dancers for great authenticity of both feeling and intention, so that an extra layer of 'performing' doesn't interfere with the simplicity of truthfulness that can be a portal to participation. To achieve this openness, I work collaboratively with the dancers using a somatic practice called Continuum Movement."

Becker is an Authorized Teacher of Continuum Movement, an innovative field of somatic education that explores the biologically-based reality of the body. The body and the planet are composed primarily of fluids. In Continuum, the fluid body becomes the material and ground of exploration through which questioning, experimentation and discovery of meaning take place. It challenges the western paradigm of the body as a fixed form, and instead the body is understood as an unfolding planetary process. Movement is something we are, not something we do.

Robin and the dancers work with Continuum as a foundational investigation underlying technical training, choreographic process, rehearsal and performance. Continuum offers a process for cultivating a resonant field of relationship. For Robin, creating dance is creating community. She notes:

"Bringing Continuum to choreography supports my desire to communicate effectively. Fluid systems characteristically function in resonance (immediate communication) with all other fluid systems.... Exploring this fluid realm prior to engaging the language of a dance form enables us to 'speak' that language with more volume of ourselves, and with more presence.... This resonant communication and sensitivity to the field created between dancers has deeply influenced my inquiry and the quality of presence I seek. I ask dancers to take responsibility for the resonant field created between them as much as they tend their own bodies. I believe this field of resonance perceptibly touches and includes an audience during performance."

The expressions of gratitude and emotional responses from many veterans who have seen *Into Sunlight*, as well as standing ovations, the media's attention and accolades, and growing interest in the project from organizations around the US all testify to this resonance.

From this author's perspective, what happens through a performance of *Into Sunlight* is rare. The felt impact is multidimensional, beginning with the all-embracing view of author David Maraniss, whose book would have us consider equally the common human values and impulses of all those concerned. Also rare is the way Robin Becker has transcribed some of the book's powerful images from language into deeply resonant choreographic images, with enough surrounding time and space for an audience to feel the invitation to imaginatively participate, to co-create a meaningful experience. And with a Continuum-based foundation for work, the Company of dancers circulate powerfully felt performances amongst themselves and audience members.

*Into Sunlight* constitutes a model for dance's fundamental role in addressing the individual and societal devastation of war by offering a medium for healing and dialogue. It has the potential to elicit within us a personal awakening to the field of possibility, which in turn inspires us to take action for our own betterment, and for a greater community. Because of this, *Into Sunlight* has provided the focal point for educational residencies and multidisciplinary conferences, at the University of Wisconsin-Madison and Hofstra University, bringing the perspectives of History, Psychology, Political Science, Trauma Studies,

Anthropology, Visual Art and Theatre to the dialogue about war's impact. After every performance, audiences have been engaged in discussions, expressing their emotions, concerns, interpretations, and ideas for action. In this open space following each performance, the dance sustains its shared movements toward healing. Dance transcends language, place and culture. *Into Sunlight* and its healing potential can be applicable to a worldwide audience.

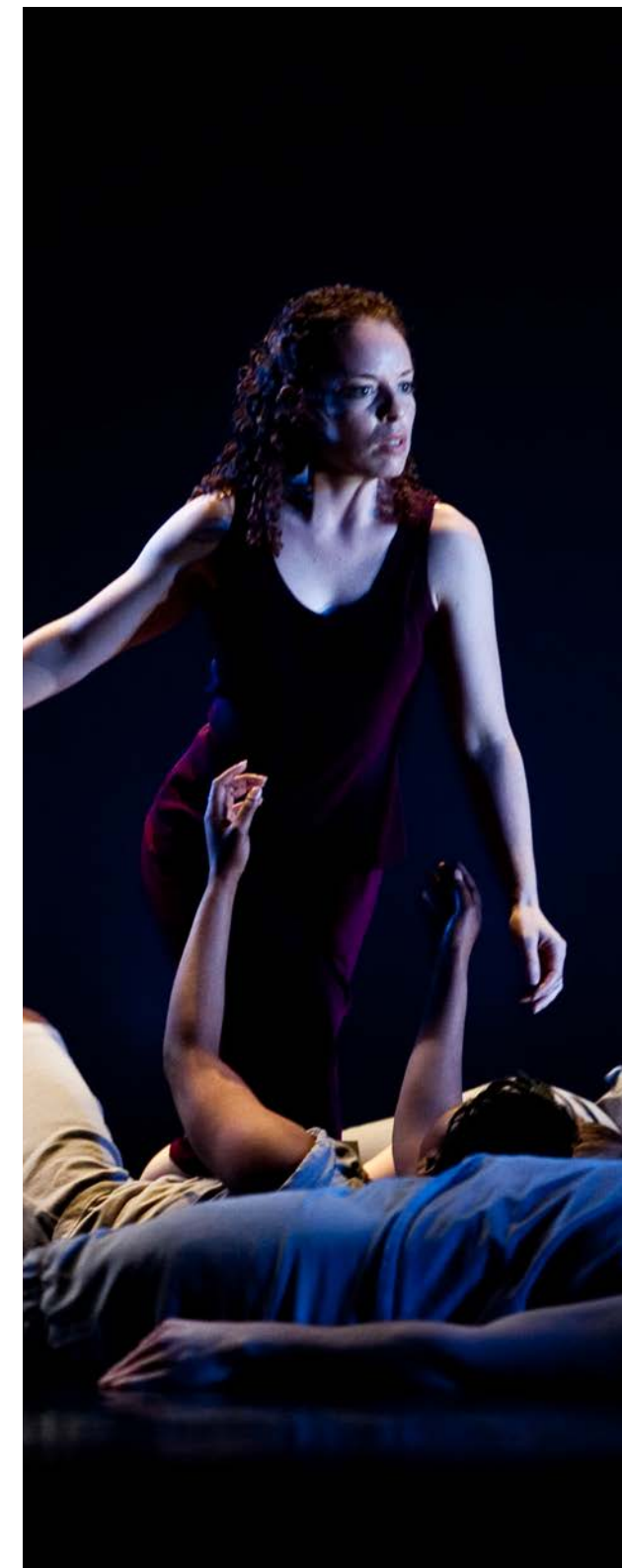

Photo on the opposite page:  
Sarah Parker in the section,  
"Until the Angels Came."

Photo on this page:  
Nicole Sclafani in the section,  
"A Dream of Goodbye."  
Photos by John Maniaci.

*Into Sunlight* was performed  
October 25-27, 2013 at Florence  
Gould Hall, 55 E 59th Street,  
New York, NY

*Into Sunlight* thanks the following  
sponsors:  
O'Halloran Foundation, Rockefeller  
and Co., Sorgente Foundation,  
7FCornerstone, Fortuna Fine Arts  
Ltd., The Merrin Gallery, Michelle  
Picard.

[www.robinbeckerdance.org](http://www.robinbeckerdance.org)  
[www.intosunlight.org](http://www.intosunlight.org)



# When are “Sustainability” Benchmarks Unsustainable?

CENTERPOINT NOW invited photojournalist and founder of *Basetrack*, Teru Kuwayama, to describe his vision of “sustainability” in the context of his experience documenting both US military activity and the local civilian population in Afghanistan.

## **Where have you encountered the term “sustainability” and what does it mean to you?**

“Sustainability” is sometimes a meaningful concept and often a buzzword, or a term that becomes perverted in its usage. I constantly hear the idea of sustainability being raised when I try to get information out about a situation, or try to deliver assistance to the people I’m photographing who live in dire conditions. When approaching a donor, they frequently say, “that’s important, but how is it sustainable?” There’s an implicit expectation that doing something important should somehow generate a long-term solution, so as to not require external support in the future. I understand the parable about “giving people fish” versus “teaching them how to fish,” but I also think we have a convoluted way of looking at these issues. For example, a decade-long war in Afghanistan doesn’t have sustainability benchmarks, but the most crucial things on earth, like feeding hungry children, or informing and educating the public through journalism, are expected to be “sustainable,” and have viable business models attached to them. I think that’s perverse. Certain things have to be done, regardless of whether or not they can be self-sustaining. It’s unsustainable to keep demanding arbitrary sustainability requirements for actions that are vital. It’s unsustainable to allow poverty, ignorance and conflict to proliferate in the world. To say we’re only going to support initiatives that alleviate problems when they meet donor benchmarks as described on administrative forms is the wrong approach.

## **Could you provide a specific example?**

I’ve been to Afghanistan twice in the past two months. The first time, I went to do a broad survey of what had happened since I left. I spent part of my time embedded with the military, which is focused on launching the Afghan security forces. I actually saw that they made progress, but I didn’t see how it could be considered “sustainable.” We’re building a force of over 350,000 armed police and soldiers, but there doesn’t seem to be a viable plan to support that force over the long term. I was embedded with marines who had just completed an 82 million dollar infrastructure project to build a base complex for the Afghan army right next to the massive US military base complex that they were dismantling, and there was already consensus that the new one was unsustainable, because the Afghans won’t have the ability to provide it with fuel and water, and it’s situated in the middle of the desert. Then, in Kabul, I witnessed glass, steel and concrete everywhere with massive high-rise buildings, shopping centers, and wedding halls, paid for, in no small part, by the spill off from hundreds of billions of dollars of US military spending in Afghanistan through politically

connected local contractors. What will happen in a year from now, when external support evaporates? In the middle of all this expansion, you see refugee and IDP camps, which are being called “informal settlements,” because the UN doesn’t want to recognize the dwellers as refugees or internally displaced people. There are 50 to 80 shantytowns surrounded by these new construction sites and inhabited by people living in absolute squalor with no access to drinking water, and children freezing to death in the winter. Yet, when you ask where the support is for these people, the typical response is: “If we give them food or water, they’ll never leave; it’s unsustainable.” I understand the concern, but I can’t comprehend how certain critical matters are faced with the restrictions of being “sustainable,” while, for many projects that receive blank checks, it’s questionable if we should be doing them in the first place. With journalism, it’s the same situation. Organizations are now trying to figure out the path forward for journalism, and the “sustainability” requirement is one that constantly comes up, as the journalism industry tries to wrap its head around the question of how to survive financially. I think the question has to be reframed. If we look at the war in Iraq, trillions of dollars were spent and catastrophic amounts of blood were spilled, in large part because of a poorly informed and engaged public. There’s a huge cost to not having a good information flow, but the journalism industry persists on questioning the value of journalism if it can’t be viable commercially. By that same logic, we should give up on public education and even on parenting. Should I ask my daughter to explain to me how she is a sustainable venture? By any practical standard, she’s not, but there’s no doubt in my mind that there’s nothing more important than providing her with everything I can. The flip side would be to recognize that if I didn’t care for my child, she would have problems that are far more costly to myself and to society, than the responsibility of taking care of her in the first place.

## **How is your practice of making your photography available to the public for non-commercial use viewed by your colleagues?**

Among many of my colleagues it’s controversial to allow one’s work to be published free of charge. Many people think I’m a heretic by letting people download my pictures for free. Selling to the highest bidder may be logical if one photographs celebrities. But when you are photographing children in refugee camps, dealing with difficult subjects that people don’t instinctively want to grapple with, to not let anyone see the work unless they pay enough is counterproductive to our stated goal of making the world a better place. I believe people see that inherent contradiction and that’s one of the reasons why the journalism industry is in crisis.

## **One of your previous initiatives, *Basetrack*, was eventually shut down on the grounds of security concerns. Is censorship an issue?**

When reporting on wars and military operations, there will always be elements that will try to control, spin, or block information, but self censorship is what’s most detrimental. The big issue of the day is privacy and surveillance, with the government harvesting communication, but the New York Times had that story for at least a year before they reported it. So there are two parts: Governments try to hide uncomfortable information and news organizations have been complicit in accommodating them.

## **Does the practice of being embedded with the Marines impact your perspective?**

When embedded, you have to be cognizant. The artificial approach is to imagine that one can avoid being influenced by the people in one’s surroundings. I find the attitude of people who criticize embedded reporting, claiming that it’s an inherently flawed system, to be strange and slightly disingenuous. What kind of reporting is not flawed in the same way? The only difference when I’m with the military is the use of the word “embedded.” While living with any community, be it the military or Tibetan monks, I’m influenced by them and grow to appreciate them. Why do people think that in some contexts their activity is pristine and untainted, while in others it wouldn’t be? When I’m embedded with US marines, they do have an effect on me. The same happens when I’m with refugees in Kabul. That’s not fundamentally a problem at all; that connection and compassion are the basis of good work.

## **What is your current focus?**

I’m working to bring relief to one of the settlements in Kabul, which, as I mentioned before, isn’t being classified as a refugee or IDP camp by UNHCR. I’m trying to figure out ways to bring water, and in a few months, when the winter conditions set in, blankets and heat as well. I’ve been talking to a handful of local NGOs, as well as to an American NGO that may become a fiscal sponsor, and to a small network of photojournalists who are interested in doing more reporting from the camp. A philanthropist from the TED network has offered frequent flyer miles to enable travel. There are many pieces and players up in the air, so I will soon be heading back to Afghanistan to develop the project further. My goal is both to deliver relief and to raise the question of why, after spending hundreds of millions of dollars, in many cases, on projects that are unproductive and unsustainable, we are not attending to the most obvious humanitarian needs.



Photos first row, left to right:

Khost, Afghanistan 2004.  
Nosari, Pakistan Administered Kashmir 2005.  
Kabul, Afghanistan, 2002.

Photos middle row:

Wakhan corridor (Tajikistan border), Afghanistan 2005.  
Badakhshan, Afghanistan 2005.  
Muzaffarabad, Pakistan Administered Kashmir, 2006.

Photo on the bottom:

Siachen Glacier, Indian Administered Kashmir 2002.





# Thoughts on Sustaining the World’s Cultural Heritage

by Robert J. Koestler  
Director of the Smithsonian’s Museum Conservation Institute

The creation of art, literature, music, monuments, and new ideas is a precious human capability. To me, such creative activities are an essential component of what it means to be human, and I have to admit that I tend to value creative types, who come up with new things, more highly than business types, who merely manipulate these things that others have created. I feel that the creators of the world’s cultural heritage are the true givers to society. While I myself lack the ability to create heritage, I do have the know-how to use science to find ways to sustain and preserve it for future generations. This is where my Smithsonian unit, the Museum Conservation Institute, fits in. Our goal, to preserve the world’s cultural heritage, is subsumed under the founding goal of the Smithsonian Institution, which I am ever inspired by: To further the increase and diffusion of knowledge among people.

At the Museum Conservation Institute (MCI) we’re engaged in research focusing on understanding the chemical, biological, and physical factors involved in deterioration in order to improve our ability to preserve cultural heritage. This is a complex undertaking. Understanding how an object is affected by one factor, such as temperature or humidity, is difficult enough, but when you combine several factors the answers are not always clear. For example, biological growths that cover carved stone surfaces can be protective by keeping wind, rain, and sun from eroding or heating the surface of a monument, or these growths can be damaging, by keeping the surface wet, chemically etching it, or mechanically marring it through root growth. It all depends on the type of growth on the surface and the surrounding climatic conditions. What we ultimately recommend to help

sustain a particular piece of cultural heritage requires exploratory investigative research, based on the scientific method. It is a process of hypothesis formation and testing, repeated many times, as we try to improve our understanding of what is happening in nature, as well as the specific case of each manmade object.

Often, our mistakes in attempting preservation provide valuable insight into what not to do in the future. Here’s an example: In 2010, I was invited by the French Ministry of Culture to serve on the Conseil scientifique de la grotte de Lascaux, the international group charged with overseeing conservation of the famous Paleolithic wall paintings in the Lascaux cave. The site had suffered a massive fungal infestation in the early 2000s, and what we found was that this problem was due to three events that happened at about the same time: The first was the decision to temporarily open the cave entrance to allow large air-conditioning equipment in; the second was a change in the way the internal environment was controlled (from dew point control to temperature control); and the third was the fact that the air-handling equipment change was made during an exceptionally rainy season when, unfortunately, a potato fungus was rampant in the area around Lascaux. The confluence of these events led to a massive influx of a white fungus into the cave. If only one factor had been present, it is likely that the cave would not have become fungally infested. But unfortunately this cave, which had survived some 16,000 years with only small natural changes to the Paleolithic art, suddenly suffered rapid human-caused changes within a few years. The knowledge gained from this investigation should help reduce the likelihood of similar events.

Even if new knowledge is developed that helps preserve heritage, it sometimes takes a long time for it to be accepted. For example, the MCI, over the course of some 20 years of research into the effects of temperature and humidity on materials, determined that we could let both parameters vary more than was allowed by the conventional conservation-world wisdom. Allowing the temperature and humidity to move a few extra degrees or percentage points either way saves huge amounts of energy and reduces the carbon footprints of museums. But it has not been easy implementing this change. It seems to be human nature that once an idea is generally accepted and people have been trained to work within its parameters, they are hard pressed to understand that that idea could be wrong. The museum world is slowly embracing the new research, but full acceptance will take a while.

Science can help us reduce the number of errors and bad choices we make in the effort to sustain our heritage, but no matter how well we accomplish our task, all too often, events outside our control cause catastrophic damage. The event may be a cultural disaster, e.g., when a group devalues previous civilizations’ culture or monuments, such as when the Taliban in Afghanistan destroyed 2000-year-old Buddhist statues, or a natural disaster, such as Haiti’s recent earthquake. After that event, MCI conservators were able to help save some of Haiti’s sculptures using knowledge gained over years of conservation research studies, and we’ve assisted after other natural disasters, such as the recent Hurricane Sandy. In that instance, we went to New York to advise on how to handle the recovery of waterlogged and fungus-infested wooden objects—how to reduce the airborne

fungal spore load by using enclosed UVC lamps while fan-drying the objects. Organizations such as the MCI, necessary in sustaining heritage under normal circumstances, become a critically important resource when disaster strikes.

Our cultural heritage should never be taken for granted; preserving it is a big task, requiring many people to care and take action. Such action might include visiting museums and monuments, letting others know how important cultural heritage is in a civilized society, and writing letters to the editor and legislators, when necessary. If we all work together, we can sustain the treasure of humankind’s best creations.

*Photo: Paleolithic bulls and other animals crowd calcite walls at Lascaux. The paintings were done by prehistoric artists over 17,000 years ago. Photograph of Lascaux cave by Sisse Brimberg from the National Geographic Creative. Image courtesy of the Smithsonian Institution.*

[www.si.edu/mci](http://www.si.edu/mci)

Robert J. Koestler holds a doctorate in biology from the City University of New York and has worked for more than 35 years in the museum field, first at New York’s American Museum of Natural History and then at the Metropolitan Museum of Art prior to joining the Smithsonian. He is editor-in-chief of the journal *International Biodeterioration and Biodegradation*.



# The Beauty of Balance—

## Wenzhi Zhang and the Renaissance of Lacquer Painting



Born in Guangzhou, China, Wenzhi Zhang has become an artistic presence in three continents. Harmonizing the ancient Eastern traditions of lacquer art and calligraphy with inspiration from modern art of the West, Wenzhi is actively re-introducing lacquer art forms to the world, including to younger generations in China.

She notes: “The spirit of lacquer culture, which is of grandeur and extravagance, is still very precious to people in the modern world. We should continue to discover and carry forward the greatness and power embodied in lacquer art, which is the manifestation of the vitality of the Chinese nation over the past thousands of years. China is the cradle of lacquer art and modern Chinese cannot shy away from the heavy responsibility and great mission of promoting this art to the larger world. As a contemporary artist, I must work to free viewers from the limits and boundaries set by old perceptions and bring them back to the shining world of lacquer painting.”

Quoting her mentor, Professor Cai Kezhen, Wenzhi recalls that “lacquer paintings are the truest Chinese paintings,” and is mindful to adhere to the elaborate lacquer techniques perfected by Chinese masters. Similarly, she researched historic calligraphy from China, Japan, and Korea for inspiration. As said by Qinqun Chen, Associate Director of the Lacquer Art committee of China, “If Wenzhi Zhang’s *Landscape* is an example of the transition of lacquer art from traditional to contemporary, then her *Sacred Calligraphy* and *New Sacred Calligraphy* have entered into the realm of the modernity of traditional literature and painting.”

While her application of colors is based on the aesthetics of the Chu Dynasty (circa 1030–223 BC) emphasizing “boldness, colorfulness, uniqueness and sharpness,” and symbolic meanings attributed to colors, “gold represents the brightness of the sun; black embodies the darkness of the universe and the night sky that house the stars; red symbolizes passion and love,” the *Sacred Calligraphy* and *New Sacred Calligraphy* series demonstrate modern western influences as well.

Her contemplation of and communion with the works of Matisse, Picasso, Kandinsky, Klee, Miró, Andy Warhol, and especially Mondrian, with his use of geometry, have greatly impacted Wenzhi’s work and shaped her understanding of abstract art: “I learned from their paintings that the most fundamental principle of abstract art is balance.”

Regardless of the medium, Wenzhi’s work carries within it the fusion of East and West, of personal character and collective memory. In the foreword to the book presenting her exhibition of bronze and ceramics, *Duality*, (QCC Art Gallery Press, 2011), Professor Daojian Pi of the South China Normal University, Guangzhou, states: “Among the contemporary ceramic artists in China, Wenzhi Zhang is a typical representative of those artists who have frequently traveled between China and the US and around the world for the past decade. Perhaps it is the abundant cultural experiences and the broad cultural horizon that shape Wenzhi Zhang’s cultural ideals, highly featuring the integration of conflicts. Because of this, we can observe these conflicts of the oriental Monistic wisdom and western philosophy from the deep recesses of her *Dualistic World of Stoneware and Bronze*.” In his essay, “The Grotesque and the Beautiful – The Art of Wenzhi Zhang,” Ronald A. Kuchta of the Loveed Fine Arts Gallery in New York comments: “...Wenzhi Zhang’s art emanates from her own experiences as well as from her keeping in touch with social issues of concern to those most affected (including herself) by significant changes in Chinese society.... In 1977, the program sponsored by the government called ‘The People to People Program,’ attracted about 25 American art museum directors and deans of university art departments to meet with our counterparts in each of the major cities of China.... Since then, the engaging events in China have produced a new world for the country’s contemporary art and there is no doubt that Wenzhi Zhang’s works are the proof.”

Art on opposite page:  
New Sacred Calligraphy  
Gold No. 2



Wenzhi’s remarkable range, profound connectedness to her own culture and openness to diverse influences have prompted her to write and lecture extensively in universities worldwide. Wenzhi holds an MFA from the Guangzhou Academy of Fine Arts and is currently pursuing a Ph.D. at the Seoul National University of Sciences and Technology in the Republic of Korea while working and teaching Ceramics at the Guangzhou Academy of Fine Arts, China. Her work has won numerous awards and is featured internationally from the National Art Museum of China, Beijing, to the collection of Queen Margrethe II, Denmark, and the collections of US Sotheby’s VIP collector, Michael Bolla, among others.





CENTERPOINT NOW invited Capoeira Regional Master,

# Mestre Kiki da Bahia,

to explain how the Brazilian martial art of Capoeira embodies freedom and tradition:

Capoeira started before the abolition of slavery, when slaves were fighting for freedom. Historically, Capoeira had no name; it was from the street. The name “capoeira” came from the indigenous Tupi-Guaraní language. “Capoeira” was the name used to refer to a place where weeds had grown tall after the corn, potatoes and vegetables had been collected. People who fought for freedom and escaped would run into the capoeira to hide in the tall weeds...that’s how that name became attached to the practice.

Many Brazilian traditions that are world-famous today originated with the Africans who were brought to Brazil as slaves. The dish known as “feijoada” was made from the guts of animals and everything the slave owners didn’t want to eat. The famous drink “caipirinha” was a mix of alcohol with brown sugar and lemon used as medicine to heal a cold. The instrument associated with Capoeira, the berimbau, was introduced much later; the music was originally drums and hands, and the berimbau was initially used to sell chicken and food.

When Brazil was at war with neighboring countries Argentina and Paraguay, the Portuguese sent all the Black slaves to the frontlines with no weapons except for razor blades, rocks, long nails, and Capoeira. Although many fighters died, the Portuguese realized how strong they were and banished Capoeira from the streets, making it illegal along with their spiritual practices, like Candomblé.... Many capoeiristas practiced in hiding. Most heroes from that time are not recognized because no one ever wanted to make a hero out of Black man, but two who are known are Ganga Zumba and Zumbí. Their fighting drew the government’s attention. Zumbí was killed because slaves who escaped ran into the mountains to stay with him and under his leadership were forming their own society. Even though Zumbí is famous today we have no pictures of him, because when he was tortured his face was destroyed to the point that it became unrecognizable. The practice of Capoeira continued despite the oppression that lasted into the 20<sup>th</sup> century. Manuel dos Reis Machado, Mestre Bimba, was born in 1900 and he went on to bring Capoeira to a new level. In the 1920s and 30s he developed “Capoeira Regional” and was asked

Cliemério de Souza Gomes Neto, Mestre Kiki da Bahia, is the United States representative for Ginga Associação de Capoeira.

www.gingacapoeira.com

to make a presentation in the governmental palace. He thought he was going to be condemned, but instead he wound up shaking hands with President Getulio Vargas, and Capoeira was legalized.

I was introduced to Capoeira by my father, but then became a student of Mestre Itapoã, who was a student of Mestre Bimba, and so I continue the tradition of Mestre Bimba’s “Capoeira Regional.” I have nothing against the “Angola” style of Capoeira, but the name bothers me. When slaves were brought to Brazil, everyone said they were from Angola, but it wasn’t true; only the boats departed from Angola, but the people who were enslaved came from many countries across Africa.

There are people in Brazil who say that Mestre Bimba “whited up” Capoeira. Mestre Bimba didn’t “white up” Capoeira, he Africanized his students, teaching them how to play music, learn about Candomblé, learn Capoeira and many aspects of Afro-Brazilian culture. He made many presentations in the government palaces across Brazil to introduce Capoeira to the country and to the world. He was a high champion in Capoeira, like his father was in Batuque—another Brazilian martial art that was outlawed—and he wanted to prove to the world that Capoeira was not a dance. Mestre Bimba was also a great fighter in Vale Tudo (Mixed Martial Arts). He was a visionary. “I didn’t make Capoeira Regional for myself; I made it for the world,” Mestre Bimba used to say, and his vision has come true because in every corner of the world today you can see Capoeira being played. He established the first Capoeira Academy. Unfortunately, one of the outcomes of opening up Capoeira has been its commercialization. What was a method to fight for freedom has now become known as a dance for entertainment. Capoeira is such a historic martial art, but it hasn’t found its place in the Olympics because of lack of vision today and internal politics. My vision is for practitioners to unite around Capoeira’s core values and continue teaching with respect for the traditions preserved by the Mestres.



2



3



1

Photos provided by Grupo Ginga  
Photo on opposite page: Mestre Kiki demonstrating *Aú Chibata*

1. Mestre Bimba with *Canhão*, *Itapoã*, and *Medicina* in front of Mestre Bimba’s Academy (1970)
2. Mestre Itapoã and Mestre Kiki demonstrating *Vingativa* at a *batizado*
3. *Itapoã* (right) and *Gia* demonstrating *Vôo de Morcego* for Mestre Bimba, *Bolao*, and *Volta Grande* standing at right (1968)
4. Depiction of capoeiristas practicing before the abolition of slavery



4



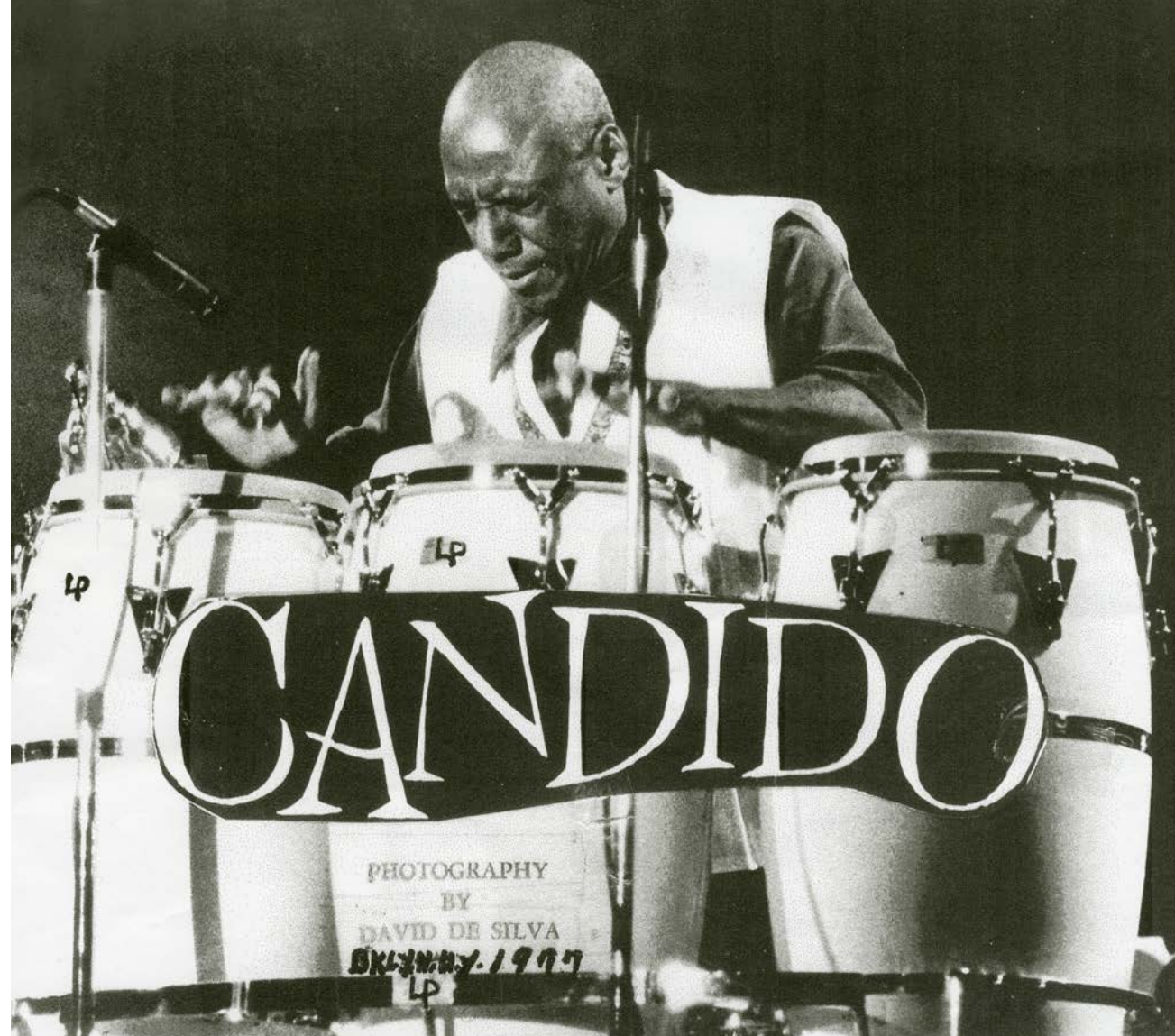

## Cándido Camero and Carlos del Pino: *Cuban music across generations and genres*

### **How have you been able to maintain your connection to Cuban culture while living abroad for such a long time?**

**Cándido Camero:** You can take a Cuban out of Cuba, but you can't take Cuba out of a Cuban. Music brought me around the world. I arrived in New York for the first time on the 4<sup>th</sup> of July, 1946 with a pair of dancers, Carmen and Rolando. By birth I'm Cuban, but I'm also grateful to be an American citizen. I am very proud of my parents, because if it weren't for them, there would be no Cándido. I started playing with two empty cans of condensed milk. I was four years old and my father put skins on them because he didn't have money to buy the real drumheads. When I would come home from school, I would play on the table while my mother was preparing lunch, and she would tell me: "Your hands are going to hurt. That's not skin, it's wood." And my grandfather would tell her: "Let him be; one day he'll be world famous." It seems he already saw what the future would hold. I don't like to talk about politics, because I'm not a politician, and it doesn't even interest me. I don't like to speak about religion, or race, or nationality.

### **¿Cómo han mantenido su conexión con la cultura cubana viviendo fuera del país durante tanto tiempo?**

**Cándido Camero:** Se puede sacar a un cubano de Cuba pero no se puede sacar Cuba de un cubano. La música me ha traído al mundo entero. Llegué a Nueva York por primera vez el 04 de Julio de 1946 con una pareja de bailarines, Carmen y Rolando. Por nacimiento nací en Cuba, por agradecimiento soy ciudadano americano. Me siento muy orgulloso de mis padres, porque si no fuera por ellos no hubiera Cándido. Empecé a tocar con dos laticas de leche condensada vacías. Tenía cuatro años y mi padre las puso cuero porque no tenía dinero para comprar los cueros. Cuando yo venía de la escuela, yo tocaba en la mesa y mi mamá estaba cocinando el almuerzo y me decía, "Te van a doler las manos. Esto no es cuero, es madera." Y mi abuelo le decía, "Déjalo, que un día va a ser famoso en el mundo entero." Parece que ya veía lo que venía. No me gusta hablar de política por que no soy político y ni me interesa. No me gusta hablar de religión, ni de raza, ni de nacionalidad.



**Carlos del Pino:** Definitely in my career as a bassist, having had a father who played the same instrument that I would go on to study, created a solid base that is difficult to forget. My father, Rafael Ángel del Pino, inculcated a discipline in me with regard to the study of both Cuban and classical music, such that my bond with my country, Cuba, could never be broken, as it is so deeply rooted in me since my initiation as a musician. At the age of 12, I debuted with the Symphony of Camagüey. I continued to evolve musically with the Orchestra of Opera and Ballet of Havana, as well as with the Orchestra of Radio and Television of Cuba, and I was also part of a popular music group, Opus 13, formed by the first graduates of the art school.... All of these opportunities in my career influenced my artistic development greatly, both in Cuba and abroad. And these experiences have maintained my connection to Cuban music, no matter where in the world I may be.

### **Did you confront stereotypes or discrimination throughout your career? Do you believe musicians can help elevate social consciousness?**

**C.C. :** I lived through discrimination, but it didn't bother me. My conscience is clean. In Cuban music, one can note the influence of Africa, primarily in the rhythms, in the percussion. The origin is African, and it has now spread to the world. There is always someone playing a drum. Music opened Cuba to the world; it's a universal language. Good music is valued worldwide. It can be for the public, or it can be for musicians; I prefer that it be for the public. One always has to create and try to innovate in ways that are different and beautiful. If I have to return to a location, I want to come with something new, so that the public asks me: "When are you coming back?" I've had the good fortune to play with all the greats of the world—musicians who are geniuses and very humble. What matters is to respect one's self, so others will respect you. I am especially happy to know Maria Posner, a very intelligent and important person to me, Ivan Acosta, Director and Producer of the documentary *Cándido: Hands of Fire* in Latin Jazz USA, Roberto Marrero, Attorney, and, to my fans worldwide, I am sincerely grateful.

**C.P. :** Music is the reflection of the society in which one lives. The first discrimination toward a musician is when he is stereotyped according to the type of music he performs. Breaking this myth is very tied to education and the persistence to constantly improve one's technical interpretative skills. It's important to create and introduce new techniques to music, in order to demonstrate the richness of music in all its aspects, be it classical or popular. Musicians always have people who admire them, both as individuals and as artists. One must be a good musician, innovating and serving as an example that inspires others to love music, as well as a successful role model for future generations.

**Carlos del Pino:** Definitivamente en mi carrera como bajista tener un padre que ejecutara el mismo instrumento que más tarde yo estudiaría, creó una sólida base difícil de olvidar. Mi padre Rafael Ángel del Pino inculcó en mí una disciplina de estudios tanto en la música cubana como en la música clásica que hizo que nunca se rompiera ese vínculo con mi país Cuba que llevo arraigado en mí desde mis inicios como músico. A la edad de los 12 años debuté con la Sinfónica de Camagüey, continué creciendo musicalmente con la Orquesta de la Opera y Ballet de la Habana, además con la Orquesta de la Radio y Televisión de Cuba y fui integrante de un grupo de música popular, Opus 13, formado de los primeros egresados de la escuela de arte.... Todas estas oportunidades en mi carrera han servido de mucha influencia en mi desarrollo artístico no sólo en Cuba sino también fuera de mi país. Y estas experiencias han mantenido la conexión con la música cubana en donde quiera que esté.

### **¿Han enfrentado estereotipos o discriminación a lo largo de su carrera? ¿Creen que los músicos pueden elevar la conciencia social?**

**C.C. :** He vivido la discriminación pero no me molestó. Mi conciencia está limpia. En la música cubana se nota la influencia de África principalmente en los ritmos, en la percusión. Lo original es africano y se ha hecho ya mundialmente. Siempre hay alguien que esta tocando un tambor. La música sirvió para abrir Cuba al mundo; es un idioma universal. La música buena tiene valor en el mundo entero. Puede ser para el público o puede ser para músicos; yo prefiero que sea para el público. Hay que crear siempre y siempre tratar de hacer algo nuevo, diferente y bonito. Si tengo que regresar a un lugar, quiero regresar con algo diferente, para que el público, cada vez que sepa que yo voy, que vaya y me pregunte "¿cuando regreses?" He tenido la suerte de tocar con todos los grandes del mundo entero—músicos que son genios y muy humildes. Lo que tiene valor es que uno se respeta uno mismo para que se lo respeten. Estoy feliz y contento de conocer a Maria Posner, una señora muy inteligente importante para mí, a Ivan Acosta, Director y Productor del documental *Cándido: Manos de Fuego* en Latin Jazz USA, Roberto Marrero, Attorney y Acompañante Viajero, y a los fanáticos mundialmente, Gracias, sinceramente.

**C.P. :** La música es el reflejo de la sociedad donde se vive. La primera discriminación hacia un músico es cuando se le estereotipa según el estilo de música que ejecuta. El rompimiento de este mito va muy ligado a la educación y a la persistencia en elevar diariamente el nivel técnico interpretativo. Es importante crear y aportar a la música nuevas técnicas para demostrar la riqueza de la música en todos sus aspectos clásica o popular. Los músicos siempre tienen personas que los admiran tanto en lo personal como en lo artístico. Hay que ser buen músico, hay que innovar y ser un ejemplo que inspire a otros a amar la música y ser inspiración de logro para futuras generaciones.





## Musical Roots in Motion: *The Journey of Malika Zarra*

Photo by Evan Sung  
www.malikazarra.com

**“I’m always surprised to hear certain people speak about integration not having succeeded. It’s so false.”**

I was born in Morocco, in a small remote town between Taroudant and Agadir. My father went to France to work in a large factory. It was a time when France needed workers and would recruit people from the countryside by looking at their hands. They were very poor people. Those who left didn’t think about the consequences of their departure. They lived very meagerly in Europe, but for the generations that followed, it was a great gift.

I was three or four years old when I arrived in France with my mother. I went to the French school, but at home it was Moroccan culture. It’s a completely different approach to leave because one is somewhat obliged to leave, as opposed to choosing to leave to discover something. So in my parents’ case, they wanted to hold on to their culture; they became more conservative and I went to Coranic school. Whenever I visited Morocco, I realized the difference: there, no one had anything to prove; whereas living abroad, one held on to the original culture.

As with many young people, I always felt that I didn’t belong to one culture or the other, as much in France as in Morocco: in France we’re not French, and in Morocco we’re not Moroccan. It’s a personal effort to realize that we have both cultures and that it’s a richness.

Towards the age of 16, I decided to undertake a cultural activity and went to the Conservatory, telling myself that if I managed to do that, I could do many things. Eventually I discovered jazz, but I found it difficult to retain the lyrics in English because the texts of the standards I was singing, like “Stompin’ at the Savoy” or “Someday My Prince will Come” didn’t necessarily speak to me. It was in New York that I was encouraged to tap into my Moroccan culture. I started to write lyrics in Moroccan dialect, in Amazigh, one of the languages I grew up with. People clearly responded because it spoke to me emotionally; it was stronger for me. Until then, unconsciously, I thought that Moroccan, African culture was a problem because of France’s history with the colonies.

Many Europeans like to go to Morocco for their retirement. But people from there, who were poor 20 years ago, are still just as poor. It’s normal that today young people aspire to something else. The world is changing everywhere. I’m always surprised to hear certain people speak of integration not having succeeded. It’s so false, it’s intolerable to hear such things, especially during periods of elections. All the youth that is present in the economy is making society advance. Instead of dividing people, we should cherish this wealth. It’s not a burden; it’s a plus.

Je suis née au Maroc dans une petite ville très retirée entre Taroudant et Agadir. Mon père est parti en France pour travailler dans les mines puis dans une grande usine. C’était une période où la France avait besoin de main d’œuvre et recrutait dans les campagnes en regardant les mains des gens. C’étaient des gens très pauvres. Ceux qui sont partis n’avait pas réfléchi aux conséquences que leur départ allait engendrer. Ils ont vécu chichement en Europe, mais pour les générations qui ont suivi c’était une grande richesse.

J’avais trois ou quatre ans quand je suis arrivée en France avec ma mère. Je suis allée à l’école française, mais à la maison c’était la culture marocaine. C’est une démarche complètement différente de partir parce qu’on est un peu obligé de partir, plutôt que de faire le choix de partir pour découvrir quelque chose. Donc dans le cas de mes parents, ils ont voulu se rattacher à leur culture, ils sont devenus plus conservateurs, je suis allée à l’école coranique.... Quand je rentrais au Maroc, je me rendais compte de la différence: là-bas, ils n’ont pas besoin de prouver quoi que ce soit, alors qu’à l’étranger, on se rattache à tout ce qui nous lie à la culture d’origine.

Comme beaucoup de jeunes, je me sentais toujours ni d’une culture ni de l’autre, aussi bien en France qu’au Maroc: en France on n’est pas français, au Maroc on n’est pas marocain. C’est un travail personnel de réaliser qu’on a les deux cultures, et que c’est une richesse.

Vers l’âge de 16 ans, j’ai décidé d’entreprendre une activité culturelle et je suis allée au Conservatoire, en me disant, si j’arrive à faire ça, je pourrai faire pas mal de choses. De fil en aiguille, j’ai découvert le Jazz, mais j’avais du mal à retenir les paroles en anglais parce que les textes des standards que je chantais comme “Stompin’ at the Savoy” ou “Someday my prince will come” ne me parlaient pas forcément. C’est à New York qu’on m’a encouragée à puiser davantage dans ma culture marocaine. J’ai commencé à écrire des paroles en dialecte marocain, en amazigh, une des langues qui je cotoyais en grandissant, et les gens réagissaient clairement, parce que ça me parlait émotionnellement, c’était plus fort pour moi. Jusqu’alors, inconsciemment, je pensais que la culture marocaine et africaine était un problème, à cause de l’histoire de la France avec les colonies....

Beaucoup d’européens aiment s’installer au Maroc pour leur retraite. Mais les gens de là-bas, qui étaient pauvres il y a 20 ans, sont toujours aussi pauvres. C’est normal qu’aujourd’hui les jeunes aspirent à autre chose. Le monde change partout. Je suis toujours surprise d’entendre certaines personnes parler de l’intégration non-réussie. C’est tellement faux, c’est insupportable d’entendre des choses pareilles, surtout en période d’élection. Toute cette jeunesse qui est présente dans l’économie fait avancer les choses. Au lieu de diviser les gens, on devrait chérir cette richesse. Ce n’est pas un lourd fardeau; c’est un plus.

## Ademola Olugebefola, *Legacy of a Living Artist*

My *Breaking Bread* series began in 1976 as we celebrated the United States Bicentennial—when the Smithsonian Institution’s American Folklife Festival commissioned me to stage manage two traveling international performing troupes from the nations of Suriname, South America and Ghana, West Africa. As I observed the significance these men and women placed on group repast, I became acutely aware of how contemporary fast food culture was negatively impacting the age-old tradition of family and friends sitting and eating together. So this series was invented as an artistic expression antidote. On the other hand, *The Mask Study*, in using simple linear expression, reveals ‘masking’ as a Human endeavor—using costume, disguise and role playing, especially in public Festivals, to free the ‘inner being.’ These four pen and ink drawings made in 1979 are part of a larger body of work recently enlivened with added color shading done in 2013, giving them a new vitality after a virtual 34-year ‘incubation.’ I have created thousands of images over several decades in pursuit of my lifelong quest to empower the human ‘inner eye’ to see beyond mere surfaces and propel our imaginations through portals of unlimited possibilities. Thus, just as all people may experience art, music and dance within their indigenous cultural references, it is my belief, that a collective matrix also exists in the human spirit and reaches beyond physical or cultural boundaries. Within that matrix, based on my actual participation in live theatre lighting and design and my experience as a professional musician, I am convinced that specific colors and linear forms create ‘equations’ that are yet to be codified and documented, but definitely exist awaiting discovery by the world’s creative communities towards our collective realization of International Artists for Peace and World Harmony.

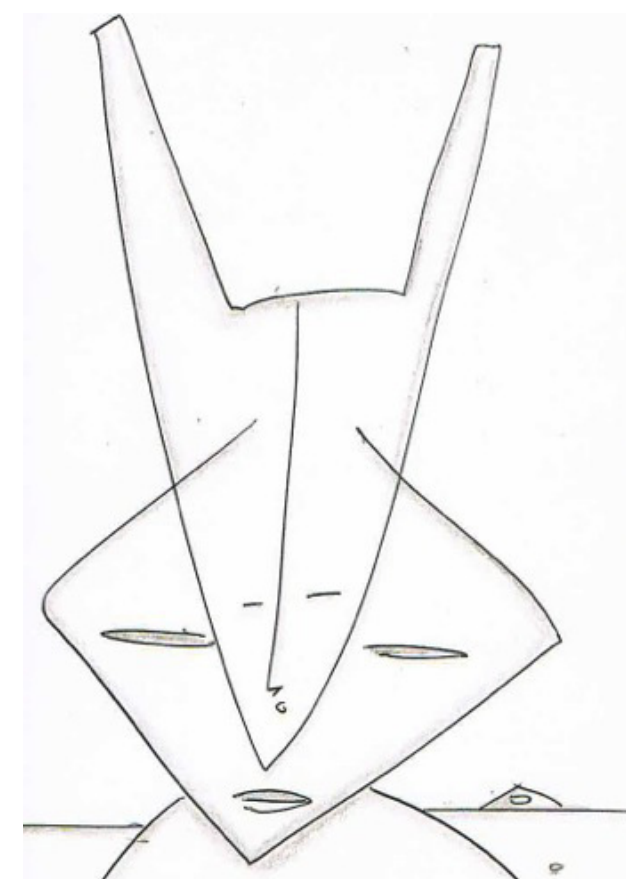

www.art-alive.com/ademola



# Las Plañideras

by Antonio Briceño



## Our Last Tears

There is a sea made up of unfathomable waters: the sea of emotions. It is host to converging torrents, attacks, rages and intensities, which seem to be contained by the over-estimated dam of reason. However, behind the concrete bounds of our logical life, lies an ocean that is endlessly swelling.

These waters free themselves via many different escape routes. The liberation that crying provides is much more than a form of therapy; in essence, it is a connection, an unequivocal expression of a powerful emotion. In this sense, professional weepers have been the quintessential officiants of the merciful ritual of crying.

Nonetheless, the act of crying has been persecuted to such an extent that the very idea of a professional weeper is, in the best of cases, a cause of discomfort today. Since the beginning of

humankind up until a few decades ago, all over the world these priestesses played their liberating, cathartic role. Their tears, which were sometimes collected in lachrymatories, were then buried next to the deceased as proof of the sadness left in his or her wake.

Now the crying has stopped and the weepers and lachrymatories have been forgotten, we have been left dry in a desert of self-inflicted exile, disconnected from our internal and external waters. We are anaesthetized in an oasis that is nothing but a mirage, pursuing headlong towards evasion, pleasure, speed and power. Our emotions are imprisoned, condemned to be ignored and never to manifest themselves. There is no faucet for them.

However, in the remote desert of Sechura, in Peru, unquenched by water for a long time now, there are still some professional weepers along with the last tears. Although they do exist, there are not many of them and certainly not enough for all our tragedies, our silent pain, our hurt and losses. There are not enough tears for the world's pain, for our pain. Yet, they continue to exist and if during the dark night of the soul you hear their sobbing, do not ask the weepers for whom they weep. You will know they weep for you.

## Nuestras Últimas Lágrimas

Hay un mar de aguas insondables; el mar de las emociones. En él confluyen todos los torrentes, todas las arremetidas, las furias y las intensidades. Aparentan estar represadas bajo la hegemonía del sobrevaluado dique de la razón. Pero tras el concreto de nuestra vida lógica, un océano se agita, incesante.

Mas esas aguas logran escapar de muchas maneras. La liberación que constituye el llanto tiene mucho más que valor terapéutico; tiene como esencia la conexión, es una expresión inequívoca de una poderosa emoción. Y en ese sentido las plañideras han sido, por excelencia, las oficiantes del rito propiciatorio del llorar.

Sin embargo el llanto ha sido tan perseguido que hoy la idea misma de la plañidera nos incomoda, en el mejor caso. Desde los comienzos de la humanidad hasta hace pocas décadas estas

sacerdotisas ejercían en todo el mundo su función liberadora, catártica. Sus lágrimas, a veces recogidas en lacrimatorios, eran enterradas junto al difunto, como prueba de la desolación que dejaba.

Una vez erradicado el llanto, olvidadas las plañideras e ignorados los lacrimatorios, hemos quedado secos, en un desértico auto-destierro, desconectados de las aguas de adentro y de afuera. estamos anestesiados en un oasis que es puro espejismo. Buscando con frenesí la evasión, el placer, la velocidad, el poder. Nuestra emocionalidad está presa, condenada a ser desconocida, a nunca manifestarse. No hay grifo para ella.

Pero en el remoto desierto de Sechura, en Perú, donde las aguas hace mucho dejaron de fluir, quedan aún algunas plañideras, con las últimas lágrimas. Aún existen, sí, pero son pocas. Insuficientes para todas nuestras tragedias, nuestros dolores mudos, nuestras mutilaciones y pérdidas. No alcanzan sus lágrimas para el dolor del mundo, para nuestro dolor. Aún existen, sí, y cuando en la noche oscura del alma escuches sus sollozos, no preguntes ¿por quién lloran, plañideras? Sabrás que lloran por ti.

Photo: Mantillas 1  
www.antonibriceño.com.ve



# Tell Me

Intimate conversations led by an artist inside  
The Museum of Modern Art in New York

by Gema Álava

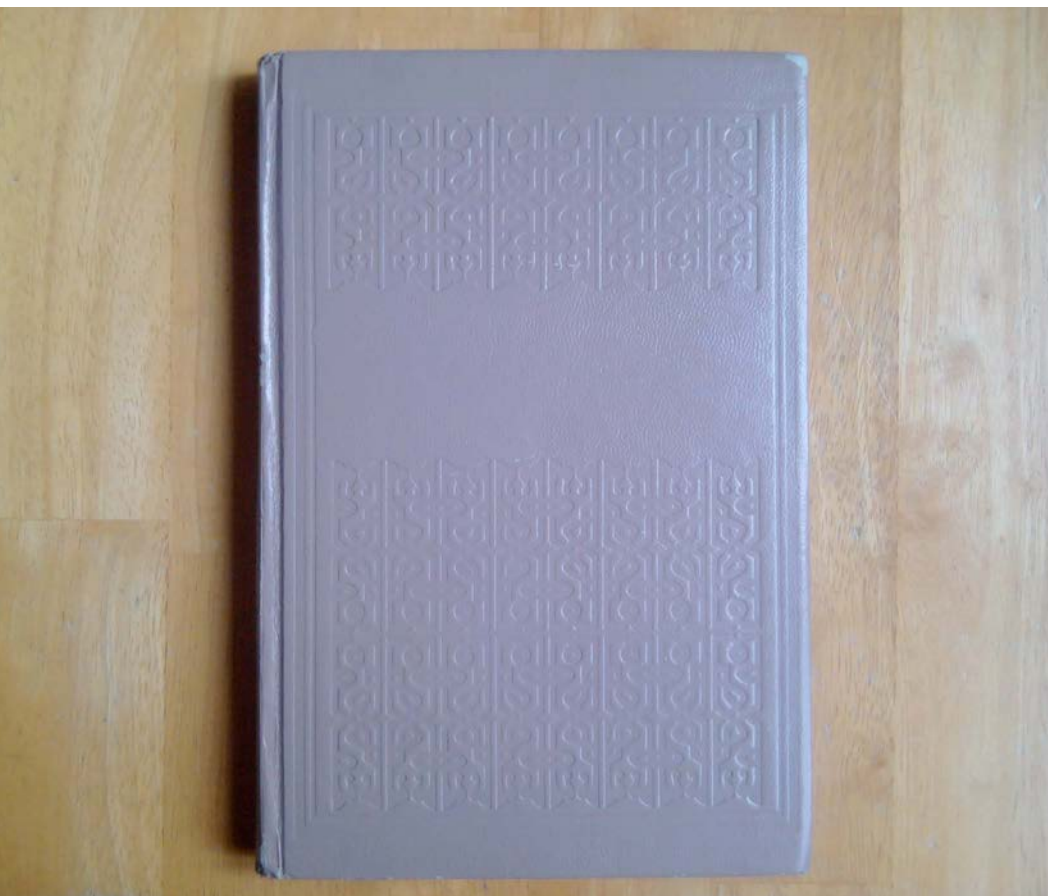

Photo courtesy of the artist.

Gema Álava is an artist from Madrid, Spain, based in New York City. Her latest project, a collaborative publication entitled *Tell Me the Truth* (2008-2013) premiered in October 2013.

[www.gemaalava.com](http://www.gemaalava.com)

TELL ME took place on Tuesdays at the Museum of Modern Art over the course of six months. “The security of the building, the art works, and the intimacy of the space itself, permitted us to have conversations that couldn’t have taken place anywhere else,” I told the director of the museum in a heartfelt letter that I handed to him in January 2009, which explained the nature of the project and invited him to be the last participant of this artistic experiment. “Encouraged by your description of the museum as a laboratory where ideas can meet works of art, and recognizing that MoMA is a place where different sensibilities can communicate with each other, I’m presenting to you an ephemeral project developed with an artist’s conviction that this journey would be very positive for the future of the arts,” the letter concluded.

I am an artist intrigued by the way the general public interacts and communicates with artworks and visitors inside museums. Museums, to me, are ideal ecosystems and stages where differences can be discussed through dialogue, making it possible to engage with the multiple thoughts that arise from these differences and increase our knowledge via interconnected fields.

Over the last 10 years I have been working as a freelance lecturer and educator in several art museums in New York City, leading more than two thousand tours and gallery talks. Museums have allowed me to experience, as an artist, the key role that museum galleries can play in the development of more just and egalitarian societies worldwide, as well as the countless interactive possibilities that can be achieved within their walls.

Some museums allow educators to invite friends to the galleries when they are closed to the general public. In 2008, during my free time, I invited 22 friends and professionals from various artistic fields to participate in TELL ME, an art project which consisted of one-on-one undocumented verbal interactions. “Artists, when allowed to experience MoMA’s collection in such privacy, expressed some of the most interesting ideas and concepts for art projects one could imagine.” Participants of TELL ME included former directors of European art museums; internationally acclaimed artists whose paintings were on view during our walks; founders of art magazines; writers; choreographers and composers, among others. They shared their impressions in a notebook that documented each one of our encounters: “I sensed a call in one of the galleries, a flame;” “I was uplifted by our conversation;” “You re-opened my eyes,” they wrote.

We all have to work together to make good ideas visible.

Words might not have a physical presence, but they do have an extraordinary power: they can change the future. They can create or destroy. In a time when we communicate via systems and devices that observe and absorb us with their charming efficiency, when do we decide to have face-to-face encounters? What do we tell each other when nothing and no one else is listening?

# A Digital Storyteller

*A Message from Native American Hip Hop Artist, Frank Waln*

I was about 12 years old, in the sixth grade, when I found a hip hop cd on the side of the gravel road while walking on the reservation in my community. I had never listened to music much, except for the radio, occasionally. When I found that cd—it was Eminem’s *The Marshall Mathers*—I related to the catharsis of getting all these emotions out that he had about his turbulent childhood. As I grew older, I continued to feel a connection to hip hop because it’s a form of storytelling, and for the Lakota people, it was thanks to our strong oral tradition that our identity and language were passed down through generations. So in hindsight, it was a natural progression for me to fuse my culture and tell the stories I wanted to tell with hip hop music.

It used to be illegal to practice our traditions; our culture was oppressed for a very long time, and my generation is now trying to reclaim it. But these days, most people only know what they see on the media, and since the media doesn’t portray us for the general public, we don’t exist. I first realized this when I moved to Chicago and was living in the dorms: I entered the elevator one day with my hair down, and a girl complemented me on my hair and asked me where I was from. When I said I was Native American, she said, “You guys still exist?” Other people, when they think of Native Americans, including overseas, are drawn to the image of a warrior who lives in close connection with nature. Those are stereotypes. Our culture and language are a way of life, not a religion, not something we use for money. It’s a lifelong journey for me to learn our traditions and figure out who I am and how I fit in.

I had experienced symbolic annihilation most of my life, but I didn’t know the meaning of it and had never considered talking about the systematic poverty or other major challenges we face in my songs, until I took an acculturation class with Claudette Roper. She pushed me to make a change through music. I studied hip hop history and learned about how older African American musicians and songs led to a new African American musical tradition. It made me question why, as Native American musicians, we don’t build on our own traditions. When I started incorporating traditional Native American instruments, like hand drums, shakers, and even vocals, it worked really well; it was like a revelation. Going on to win the Native American Music Awards felt like a huge dream. It still seems unreal to me and I continue to be surprised by how many people—Native and non-Native alike—took to our music and could relate to it. It’s amazing to me that I could create something that people connect with, regardless of their ethnicity.

Through my music, I speak to the issues we’re confronting. Alcoholism is rampant, as is rape and domestic violence. Statistically speaking, if I had three daughters, one out of the three would be raped, and those numbers are only based on the cases that are reported. Other problems involve powerful lobbies, like with the Keystone Excel Pipeline, which, if built through the reservation, would be built through an aquifer,

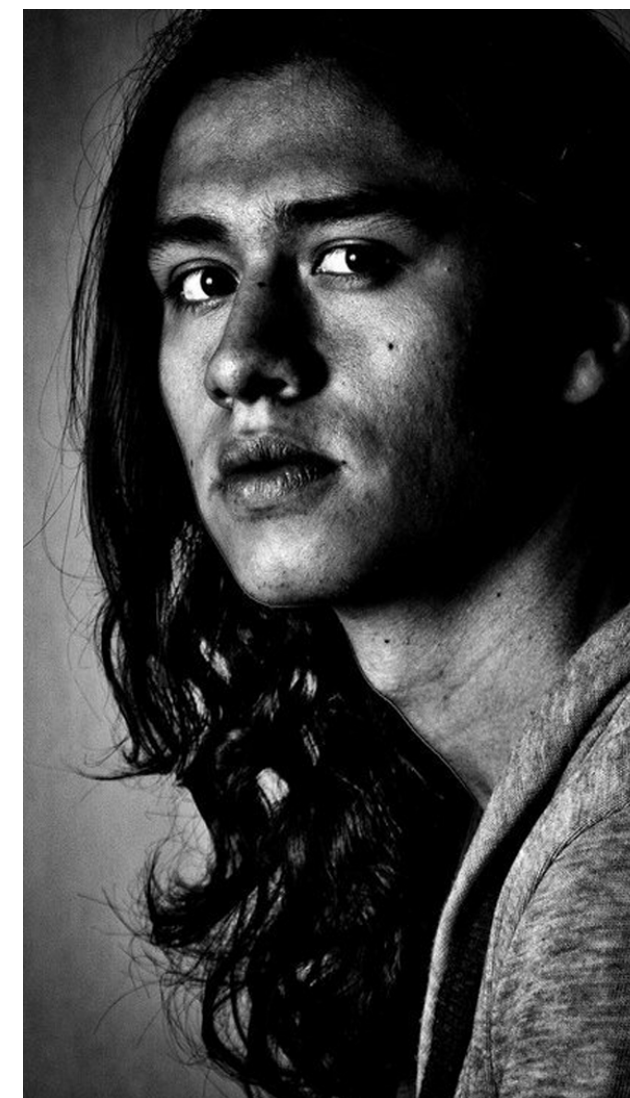

endangering our water supply. Historically, this was the worst land the government could give us, and now they’re trying to take even that away. There are many local advocacy groups trying to combat these situations, but the obstacles are enormous, as we’re among the most disenfranchised groups in the whole country. As Native Americans, we want to be acknowledged by the leaders who are making the decisions that affect us, but we also need to get our voices out into the public sphere and create media. My people have been storytellers for thousands of years, and today, I’m a digital storyteller, starting from ground zero to tell people that we’re alive and well and not happy with the way things are in the world, in our communities, and in our country. Oppression is still alive and well, but with technology, there’s an opportunity for my generation to speak out against social injustices. We know our story and need to tell it ourselves.

Photo: by Kernit Grimshaw  
[www.frankwaln.blogspot.com](http://www.frankwaln.blogspot.com)





# A DAY IN THE WORLD

**Yunnan, China, 12:45.**

*In China's Yunnan province, rope bridges were the traditional way to cross the angry River Nujiang as it flows on to Burma. Throughout the province, the government is replacing such rope bridges with modern suspension bridges, improving local infrastructure and accessibility. This man is on his way to the Lishadi village market. He belongs to the Lisu people, a Tibeto-Burman ethnic minority. The Lisu build their villages near running water, which they revere. Photo by Yereth Jansen*

[www.aday.org](http://www aday.org)  
© Max Ström



# The Future of Ancient Seeds

## An Interview with *Dr. Sarah Sallon,*

*Director of The Louis Borick Natural Medicine Research Center (NMRC) at Hadassah Medical Organization in Jerusalem*



### **How and why was the NMRC established?**

NMRC was established in 1995 as an entirely self-funded center to provide an evidence basis for the effectiveness, safety and mechanism of natural therapies and an integrated approach to their application and use. Our studies have included researching and developing the medicinal plants of Israel, researching other medical systems—particularly Traditional Tibetan Medicine—and long term programs on the effectiveness of mind-body therapies to reduce stress, especially in hospital staff. Our most recent project is applying the use of natural therapies to the food and agricultural industries, including prolonging shelf life, controlling pests, and treating infections in farmed fish and poultry.

### **In 2008 you reported in the journal *Science* the germination of an ancient date seed. This was the oldest seed, up until then, ever germinated. What is the background?**

Our seed came from Masada, overlooking the Dead Sea, the historical site of Herod's palace. Masada was used as a base by the Zealots during the Jewish revolt against Rome in the first century CE. The two-year siege of Masada finally ended in 67 CE, according to the historian Josephus, who wrote an "eye witness" account of the siege, with the mass suicide of 900 men, women and children. Josephus describes how before the Zealots killed themselves and their families they burnt their food supply, rather than let it benefit the Romans. However, as they didn't want the Romans (or posterity) to think that they had committed suicide because of hunger, they left one food storage area unburned. We think that our date seed—found during Professor Yigal Yadin's excavations of Masada in the 1960's—is one of those "unburned" seeds.

### **What led you to work with ancient seeds?**

The work grew out of our Middle Eastern Medicinal Plant Project (MEMP), which focuses on conserving, researching and sustainably developing the medicinal flora of this region, with an emphasis on Israeli medicinal plants. These plants have a long historical use extending back to antiquity and if properly

researched can have significant benefits with potential commercial applications in medicine, food, cosmetics, agriculture, veterinary use and much else. The regeneration of ancient seeds is an "offshoot" (literally) of this program and is important because many plants that once flourished in this region have become extinct. If seeds discovered in archaeological excavations can be germinated, they can open a unique window into species that no longer exist today. The date palm (*Phoenix dactylifera*) was one of the most important crops of the ancient world, and dates today are still a major export of many countries. It's therefore important to see what genetic traits "Methuselah" (the name given to our germinated date seedling) possesses, which may have been lost in modern species, e.g. resistance to crop pests, size, sweetness, and medicinal benefits that made the Judean date famous throughout the ancient world.

### **What medicinal value was attributed to dates in ancient texts?**

In Arabic and Jewish texts, attributes include anti-infectious capacity, use for depression, and as a laxative and tonic. I'm very interested in the historical use of medicinal plants to shed light on how these plants should be researched today. Based on interviews with local healers collected over many years, we have compiled a "MEMP database" that describes the historical uses of over 500 local plants in Israel. In addition, our historical research team "data mines" ancient manuscripts in a variety of languages (Latin, Arabic, Hebrew, Greek, Aramaic, etc.) for further clues on the use of plants to treat certain conditions. What we are looking for is a connecting narrative between traditional/historical uses and the modern disease we are screening for. So, if we're looking at plants with properties that may protect against Alzheimer's disease—which of course was not called that in ancient times—then we look at plants that were historically used to improve memory. Using this method of focused screening, we have been successful in identifying a number of local medicinal plants with anticancer, anti-infective and neurodegenerative activity. We are also trying to preserve this medicinal knowledge for future generations, before it's lost forever.

### **Speaking of preservation, how paramount is the need to create a global seed-bank in the event of certain crops going extinct due to climate change?**

Due to ongoing species loss, which is happening at a rapid rate, global seed-banks are of course being created. There's the Millennial Seed-bank project created by Kew Gardens and a huge seed-bank project in Scandinavia. These are on a global scale with seeds collected from all over the world and stored at low temperatures. On a small scale, as part of the MEMP project, we also collect and store seeds of local wild species at our experimental cultivation sites. We try to preserve not only medicinal plants, but also wild varieties of crops like wheat and barley that are the basis of modern staples and can also have important medicinal and nutritional value. I think that there are dangers in the mass use of genetically homogenous crops producing a standardized type of fruit or vegetable. If pests that routinely attack these crops develop resistance to the most powerful pesticides currently used, then these fruits and vegetables can be devastated with severe consequences, particularly in the developing world.

### **What other projects have you been involved in?**

When I first founded the Center, much of our original work focused on testing traditional Tibetan medicine. We worked for a number of years with the Swiss company, Padma AG, one of the few companies producing commercially available traditional Tibetan medicines. We carried out and published clinical trials on two of these Tibetan formulas—one for vascular disease called Padma 28 (also known as Padma Basic) and another for irritable bowel, Padmalax—showing that both formulas were effective. Currently we're working directly with Tibetan doctors at Men-Tsee Khang Institute of Traditional Tibetan Medicine in Dharamsala, India, examining the use of "detoxified" mercury in Tibetan medicine. This highly-treated compound known as "Tsothel," derived from mercuric sulfate, follows a complex purification process before it's considered safe to use and is an important constituent of certain Tibetan medicines. We have already published one pilot study

and are about to publish a second larger one showing that "detoxified" mercury is not associated with the adverse effects typical of mercury toxicity.

We are also researching medicinal plants for application in food and agriculture, especially against fungal and bacterial diseases in farmed fish and poultry. Currently, chemicals and antibiotics are used to fight infections, which routinely cause huge losses in these industries. The problem is that many of these antibiotics are also used in people and are increasingly less effective because of bacterial resistance—a "side effect" of their widespread use in farming. Certain chemicals are also a problem, particularly in farmed fish, due to their dangerous toxicity in humans. So searching for "natural" alternatives is really important. We also intend to study plants as natural pesticides for crops. Chemicals sprayed on crops as pesticides are ingested. We don't really know what they do over prolonged periods of time, but evidence is emerging that they may be implicated in various human diseases including cancer. They can also be harmful to the ecosystem. An example of this is the possible connection between certain types of pesticide and the widespread colony collapse of bees used to pollinate crops.

### **Do you collaborate with researchers in other Middle Eastern countries?**

Yes, as much as possible. Plants are common to all countries in the region. They don't have borders and have been used for millennia all over the Middle East. If we can forge good and productive contacts with our neighbors by researching these wonderful treasures, preserving the ancient knowledge of their use and growing them in a sustainable way, as well as producing products that benefit all of us, then I believe that we have achieved something important.

*Photo by Guy Eisner*

[www.hadassah-med.com/medical-care/clinics/the-natural-medicine-research-center.aspx](http://www.hadassah-med.com/medical-care/clinics/the-natural-medicine-research-center.aspx)



# Can Ancient Culture and Modern Business Practices Coalesce?

CENTERPOINT NOW met with Wolfgang Hamm, Managing Director of the 900-year-old Stift Klosterneuburg wine estate, to learn how the estate manages to stay current and forward-looking without compromising its rich past.



## What drew you to Stift Klosterneuburg?

I grew up in the Austrian countryside and later in life branched out and learned about challenges in the world, working across Africa and Asia, which made me humble and inspired me to take a deep interest in international development. Over time I decided that neither work on the ground as a development aid worker, nor working at a desk for a big non-governmental or governmental organization would satisfy me, and so I returned to my other passion, which is wine. I was fortunate to become responsible for the Stift Klosterneuburg Wine Estate, a unique and renowned wine estate, the oldest of Austria, at 900 years of age, and one with a very lively present and future.

## How and why did you become so conscientious of the estate's carbon footprint and other aspects of "sustainability?"

The way we work determines whether we make use of our potential, or not. In the long term, if we preserve the vigor of the soil, the vines are able to give us energetic full flavored grapes. If I just take out of the system, without giving back, I deplete it. Our vineyards have small weather stations that send us basic weather parameters, temperature, wind direction, strength, humidity, and precipitation. We want to have the best information available to take the right measures and determine how to best treat our plants. Before monitoring the data, just by being out in the vineyards every day, we were experiencing the changes in weather patterns, in pests and in the indications of diseases and fungi. We looked into our weather data and found a direct correlation. The equal precipitation distribution that we used to have was being replaced by periods of drought followed by heavy rainfall, or even thunder and hailstorms. That inspired us to extend our long-term vision for preserving our soil and not harming our climate. All people should be able to use the ecosystem without harming it. We decided to limit



our carbon-dioxide emissions to a minimum level. We worked with an Austrian NGO, ClimatePartner, to make a carbon footprint of the entire wine estate. We analyzed each step of the production process starting in the vineyards, through the cellar, up to how we used paper, how our employees got to work, how our wine reached the customer, to obtain a comprehensive picture of how we were affecting the ecosystem. The results prompted us to figure out what we could skip, where we could reduce. We started in the vineyards, constructing equipment that can condense two work processes into one, with one tractor for example, to limit emissions. We don't spray against insects at all, so as to preserve maximum diversity of vineyard fauna. We just use pheromones to disturb the propagation of one specific harmful pest. We work with different mixtures of plants within the vine and make our own compost, which we use as a natural fertilizer. In the cellar for the wine estate as a whole, we changed our energy supply to our own little power plant where we produce all our heat and energy from renewable sources, from our forest. We worked with our glass manufacturer and developed a new bottle—the lightest bottle on the market now—to save on glass and weight, which affects diesel consumption, when you consider transport. It was a very tedious process.

## This is the first wine estate in Austria to undertake such a process. Can it be easily replicated? Have other companies emulated you, or are there concerns about the costs involved?

We didn't do a return on investment calculation. This may sound unprofessional, but how do I calculate the value of cleaner air, or more fertile and vigorous soil, which simply adds more taste to my grapes? We were definitely the first in Austria to take on this challenge, and to our knowledge, we were also the first in Europe. Of course there were important investments. I don't know if we'll be able to recuperate every single euro ourselves as a wine estate, but I'm absolutely convinced that, as a society, we will recuperate every single euro spent three times over. We've been approached by many colleagues, and I frequently give lectures...we are not keeping any secrets. I happily share our knowledge, as well as our mistakes. In the end it's about stabilizing our ecosystem. The more people doing this, the better it will be for the consumers and for us all. I dream of a future where people look not for one special eco-friendly item, but rather where the norm is for products to be produced in a sustainable way and can be easily integrated into everyday life. It doesn't always have to be about "super slow-food niche gourmet exquisite brand name products" that I treat myself to once a month

to soothe my senses. As a society it would be more important to seek out less lavish products that come from sustainable sources. In many areas, like clothes, this can be difficult. With food, it's easier nowadays. Most people can't afford to always buy the most expensive super-consciously produced product, but we would all be able to afford a quality product that is produced in a responsible way. It could be a little more expensive without costing a fortune. If we were all willing not just to pay more, but also consume less fast food, or less meat, but better quality meat from animals that were raised without hormones, food would taste better and be healthier for our bodies. Maybe we wouldn't have to deforest rainforests in Latin America to grow genetically modified soybeans. Fortunately, in Austria there is a common agreement that we want to keep Austria GMO free because we believe in the diversity of seeds and in the importance of preserving a rich gene pool and handcrafted food. The average quality of food in Austria is still very high.

## Which wines are you most proud of?

Wine for me is liquid culture. It's not only an alcoholic liquid in a bottle. It encompasses so many aspects, from the soil, to the weather, to the people who made the wine. We have always concentrated on our local indigenous Austrian grape varieties. The red-wine grape, Saint Laurent, is especially close to our hearts. The success of this grape in Klosterneuburg made it spread to other wine-growing regions of Austria, and it has now become one of the three most important red grape varieties of Austria. Saint Laurent encapsulates the pure elegance of a red wine; it is a refined and reserved grape variety, but with incredible depth. Our wines are ambassadors of not only the soil they grew on, but also of Austrian culture and hospitality. The way wine is made is very much influenced by the culture that surrounds it.

## How has the history of this estate influenced its present-day activities?

Our monastery sits atop of a hill about five kilometers north of Vienna next to the river Danube. This has been a historic settlement ground, first for Germanic tribes, then for Romans 2000 years ago. In 1114, Saint Leopold, the historic ruler of the Eastern part of Austria, decided to endow this unique strategic spot sitting above the Danube, a suburb of Vienna, so-to-speak, to the religious order of the Augustinian Canons. It was an important crossroad of cultures, close to the Slovak and Hungarian border. The Danube, one of the most important waterways of Europe, crosses here. He wanted this to be a place of peace and social welfare. The monastery had three main goals—taking care of the parishes; providing a social net including schools, hospitals, old-age homes, homes for the poor and even agricultural services, teaching the local population better farming techniques; and functioning as a hub for culture with performing and decorative arts. So, it was a kind of torch in the darkness of the Middle Ages. We try to maintain this legacy. It is not only a museum, only a monastery, or only a wine estate. It is a living and flourishing place that comprehensively weaves together all of these aspects, a meeting point for people of all walks of life.

Stift Klosterneuburg mit Weingärten  
Wiener Nussberg Weißleiten  
©Stift Klosterneuburg\_Latusek

[www.stift-klosterneuburg.at/en/wine](http://www.stift-klosterneuburg.at/en/wine)



# Riding Along the Ups-and-Downs of Brazil: What Lies Ahead?

Marcos Troyjo, Director of Columbia University's BRICLab, shares his views

## Why did you transition from a career in diplomacy, to your current field, which you describe as “business diplomacy?”

I had always wanted to be a diplomat and passed Brazil's difficult entrance exam joining the Science and Technology Department of Brazil's Ministry of Foreign Affairs. I was a good speechwriter, so when Brazil was elected to a temporary term on the UN Security Council in 1997, the Ministry posted me to our UN Mission. I thought the UN was to a diplomat what Broadway was to an actor, but then I realized there was a big gap between what the UN could accomplish and what was expected of it, perhaps due to the lack of resources. When I was ready for a new assignment, a friend suggested that I take a leave of absence from the diplomatic corps because he was inviting me to set up a division of his merchant bank that would help Brazilian companies internationalize. Through the years, that led me to a series of positions and engagements including a lecture at Columbia University's Emerging Markets' program, where the Director and I spoke about how the concept of “emerging markets” was too broad. We co-conceived of the idea of the “BRICLab” to consider not only the economic aspects of these countries (Brazil, Russia, India and China), but also their foreign policy, development, what they want from the world, and what they can contribute. Outside of academia, I work to connect Brazil to the world through business, or soft power, rather than official state-centered diplomacy... I see it as business diplomacy.

## Brazil, during the Lula administration, underwent a dramatic change in terms of its global positioning. You seem cautious about Brazil's future. Why?

Ten years ago, when Lula was running for office for the fourth time, a senior economist at what was then an important investment bank said: “The worst thing that could happen to Lula would be to win the elections because if he were to win, Brazil would go down the same path as Argentina.” That economist argued Brazil's currency would melt; that there would be social unrest. In his opinion, Brazil was going to default even before Lula would take office. In those years, everyone was pessimistic about Brazil; I call that period “Brazilphobia.”

Then, between social inclusion policies and the expansion of credit to the lower-income population, 40 million Brazilians entered the consumption world. At the same time Brazil discovered substantial oil reserves sitting right off its shores and still carried out a biofuels program, with eight out of ten automobiles now running on some sort of flax fuel. This so-called “alignment of stars” made Brazil successful during the Lula years. Meanwhile, the banker who predicted Brazil would go broke belonged to a bank—Bear Stearns—that has now disappeared. The negative aspect of

Brazil's success is that by 2010 we entered a period of “Brazilmania.” We've been over-seduced by our apparent success, and our leadership reached the conclusion that we shouldn't carry out the microeconomic reforms that many people recommended with regard to labor and taxation...factors that are important for companies to be able to compete internationally. With the economic backbone of biofuels and oil, Brazil won't go broke, but if we don't increase the endogenous capacity to save and invest, Brazil could underperform. And this has been the case of the past two years.

We also need to focus more on innovation. Brazil's recent rise was marked by its emphasis on attracting foreign direct investment to produce in Brazil. The government holds the golden share in most of Brazil's important corporations, so the aim was to sell to the Brazilian government, rather than create products that would be competitive globally. Innovation is further restricted by the fact that Brazil's public sector is hyper-inflated, with a tax burden at 38% of GDP which is very onerous for a private entrepreneur.

## How does migration figure into the Brazilian economic landscape?

During the economic crisis of the eighties, we became a nation of emigrants. Since 2000, and with the crisis of 2008, that trend reversed completely. On one level Brazil is a destination for migrants from Latin America and the Caribbean seeking employment in domestic work, the textile industry, construction, etc. However, we are also seeing an increase of high-skilled immigrants, especially from the Iberian peninsula, responding to Brazil's needs in engineering, chemistry, biology, IT. Migration is a contributing factor to Brazil's economic success.

## Brazil hosted the UN Conference on Sustainable Development (Rio+20), but at the national level, is there a comprehensive strategy for sustainability? Thinking about the infrastructure projects needed for Brazil to host the World Cup and Olympic games, can these huge undertakings have a lasting benefit?

In terms of sustainability, I think the urban dimension is where Brazil has the most complex problems to tackle. It's easier to find the resources for a project in the Amazon, than for an effort to clean the beautiful, but very polluted Guanabara Bay. In terms of the infrastructure development for these major events, they will pay off, especially as a window of visibility, but shouldn't be viewed as a salvation platform, or a springboard for development. We need a long-term strategy to upgrade Brazil as a whole.

# Blurring the Line Between Species: Eduardo Kac and the “Natural History of the Enigma”

While many people experience technological advances as a factor in weakening human beings' connection to nature, for biological artist, Eduardo Kac, technology is an invaluable resource for reclaiming and deepening that bond.

In his series, entitled “Natural History of the Enigma,” Kac developed a new “plantimal” life form, infusing his DNA into a petunia. He named the resulting genetically engineered flower “Edunia,” to represent the “plantimal's” hybrid origin.

Of his work and mission, Eduardo Kac says: “The new flower is a Petunia strain that I invented and produced through molecular biology.... The result of this molecular manipulation is a bloom that creates the living image of human blood rushing through the veins of a flower. By combining human and plant DNA in a new flower, in a visually dramatic way (red expression of human DNA in the flower veins), I bring forth the realization of the contiguity of life between different species. This work seeks to instill in the public a sense of wonder about this most amazing of phenomena we call ‘life.’ The general public may have no difficulty in considering how close we truly are to apes and other non-human animals.... However, the thought that we are also close to other life forms, including flora, will strike most as surprising.”

Among his references, Kac cites the work of 16<sup>th</sup> century artist, Arcimboldo, who utilized fruits, vegetables, and flowers to depict his portrait subjects, and 18<sup>th</sup> century philosopher, Julien Offray de La Mettrie, who stated in his book L'Homme Plante (1748) that “the singular analogy between the plant and animal kingdoms has led me to the discovery that the principal parts of men and plants are the same.”

Fully cognizant of the reservations held by many regarding his process, Kac views his application of genetic engineering and unique transgenic plant as a contribution to the diversity of our world. His work is exhibited and represented internationally, and Eduardo Kac continues to develop new projects from his base in Chicago.

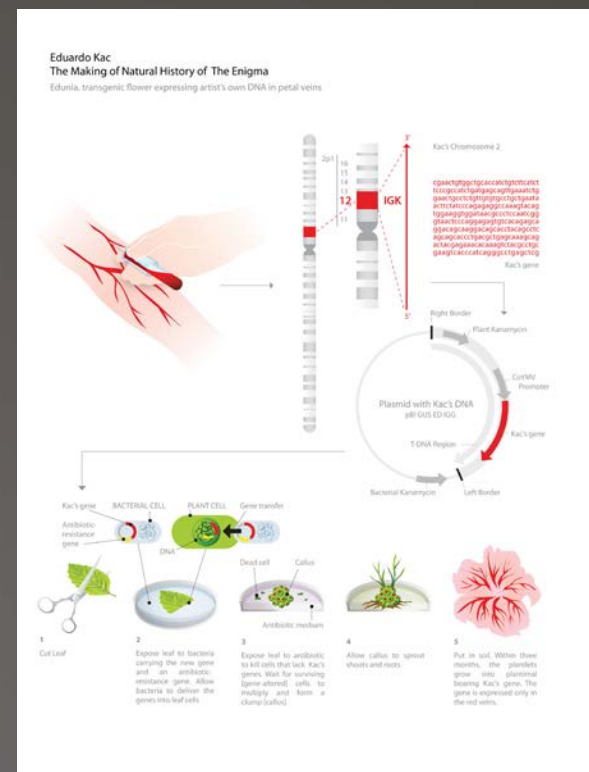

Left: EDUNIA  
Eduardo Kac, Natural History of the Enigma, transgenic flower with artist's own DNA expressed in the red veins, 2003/2008. Collection Weisman Art Museum.  
Photo: Rik Sferra.

www.ekac.org

Marcos Troyjo is a Member of the World Economic Forum's Advisory Board on 'Emerging Best Practices of Brazilian Globalizers.'

www.sipa.columbia.edu/  
briclab/  
www.weforum.org



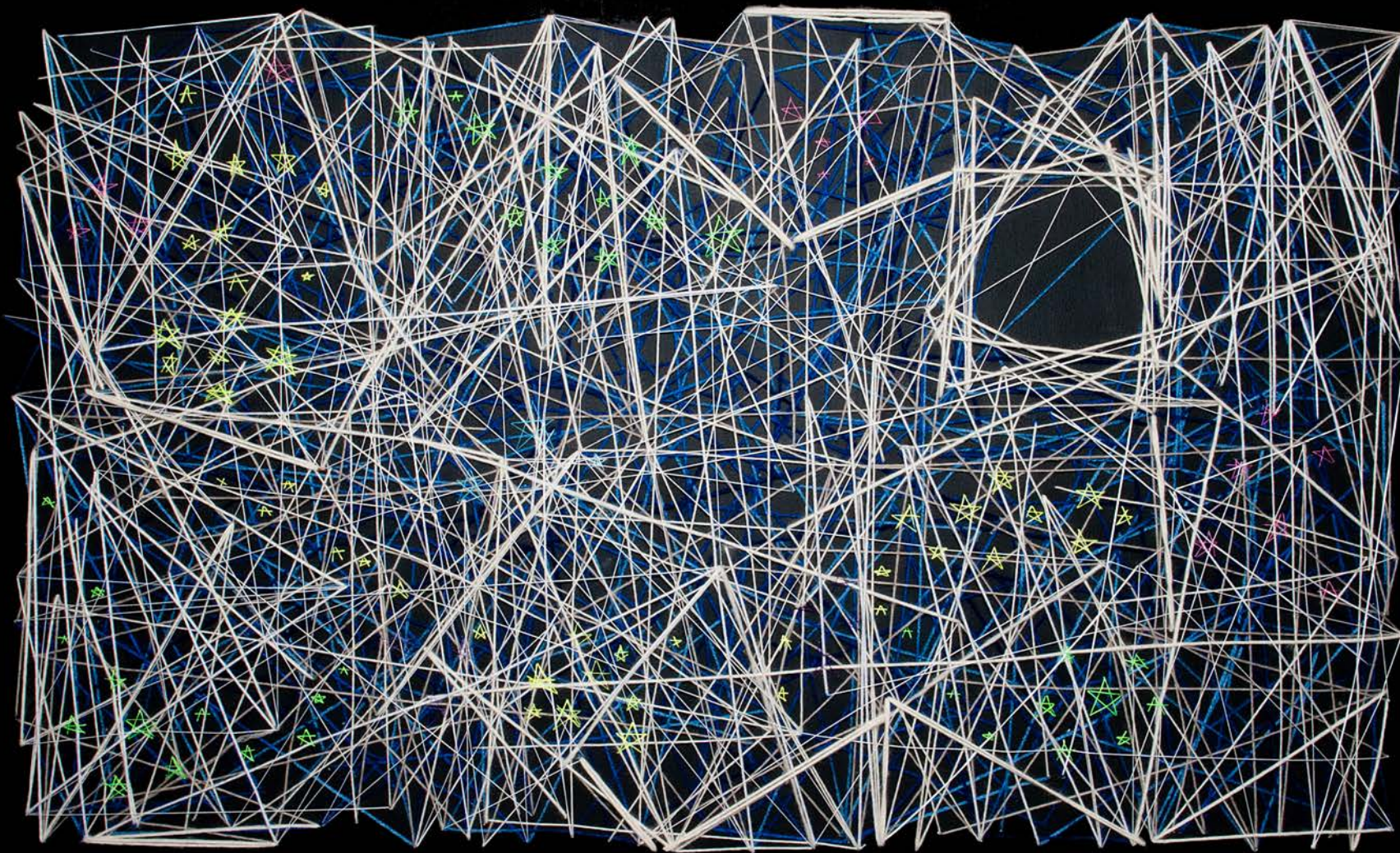

## Intricacy and Depth

### *The Work of L. Mylott Manning*



Art, top: *Fibers and Threads*;  
bottom: *Spools*.

[www.lmylottmanning.com](http://www.lmylottmanning.com)

I am a New York based fine artist; my goal is to empower people through my interactive sculptures, garments, public art projects, works on canvas and installations. Each of my projects embodies a mantra, a core voice spoken through the alteration and arrangement of my materials. It is important to me to include a portion of salvaged elements in my art. I am always on the look out for collections of vintage objects to re-work into sculptures or garments. I also spin my own fibers, using a spinning wheel. This allows me to incorporate pieces of reused fabrics, clothing, and other materials into the yarn. The textures are amazing.

I studied Sculpture and Apparel Design at Rhode Island School of Design. These areas of thought are combined in my art practice. My work relates to the body, and I often create garments for process-based performances. The found objects included in my wearable pieces range from watches, clothespins, pieces of chalk, and even solar-power toys.

A breakthrough performance of mine, *700 Spools of Thread (Keep it Together)*, presented by *chashama* and supported in part by The National Endowment for the Arts, connects with its immediate surroundings of the Garment District in New York City.

The performance entails a woman wearing a dress constructed out of vintage and contemporary spools of thread that feed into multiple sewing machines surrounding her. The entire gallery space is draped with yards of black fabric and layered with a jungle of colorful threads and yarns.

Many of my projects are an extension of this performance. The fabric, threads, yarns and spools have all been incorporated into new works, including a large wall installation at The Carlton Hotel in New York.

My intent is to relay a sense of energy in my installations and works on canvas series *Fibers and Threads*. I create quick, intricate networks of strings against a dark background. This really makes the colors pop. I intuitively connect and build up the threads, while thinking about an oscillation between opposites and layers of dimension. There is flatness and a great depth at the same time in these pieces.

It is fantastic to see the viewer's reactions to this work. People relate the structure of the strings to an organized chaos, networks of electronic technologies, and as a metaphor for the fragility of human life.

## The New Money

### *A Conversation with Jem Bendell*

by Nina Rennie

#### ***What's wrong with the financial system?***

In the next 10 years there will be over a billion young people coming into the global workforce and just 300 million jobs between them. How is it that with so much need in the world, so many people can't get a job? Could it be that our mechanism of exchange—our monetary system—is restricting us from working together, for mutual gain?

In most countries, about 3% of money originates from government mints. The rest is digital, created by banks out of nothing when they issue loans. The banks create the amount borrowed, but not the interest to be paid, so there is more debt than money. Individually we might pay off our debts, but collectively we are in debt forever and paying interest to banks. This system makes increasing inequality a mathematical certainty.

#### ***What is the answer?***

Wholesale monetary reform. We need our currencies to always be in sufficient supply to match underused assets with unmet needs. To avoid a caregiver sitting unemployed, while someone needs care, or a building lying empty, while people are homeless. Money should simply be the mechanism we use for measuring and exchanging things of real value.

#### ***How would we design such currencies?***

We already are. Across the world, people are trading in currencies their own communities run, from slums in Nairobi to enterprise hubs in Brussels. A few months ago, an alternative online currency, called TEM, was introduced in the Greek city of Volos. Members holding accounts can exchange as much as they wish, without it being restricted by availability of euros, and everyone ends up returning to zero, so no one makes money out of issuing the currency or charging interest.

#### ***Could these alternative currencies co-exist with fiat currencies?***

The oldest and largest mutual credit system—the WIR in Switzerland—has existed since 1934, and has over 70,000 members trading over 2bn WIR a year. Eighty percent are small firms that find it important for keeping business going during downturns. That's when banks restrict new credit, especially to small businesses, so these firms increase their use of the WIR to buy inventory from other participating firms. Research shows the WIR has helped the Swiss economy suffer less severe economic cycles than its neighbours.

#### ***How can alternative currencies help us meet sustainable development goals?***

With our current interest-charging system of money creation, we have no choice but to grow the economy, otherwise there will be less new debt issued to service existing debts, and there will be defaults, foreclosures, bankruptcies, unemployment and depression. History shows us this all leads to crime, extremism and even war, to say nothing of the environmental damage caused by the ever-increasing extraction of resources that such economic growth requires.

With alternative currencies, however, as all credits and debits ultimately cancel each other out, you don't find increasing amounts of money chasing the same amount of stuff or services, so the currency doesn't inflate. And no interest is charged upon the issuing of credit, so wealth isn't extracted from those with lower incomes.

And as most alternative currencies are locally-focused, they encourage us to trade locally, reducing our carbon footprint and promoting community regeneration.

#### ***If alternative currencies are locally-focused, how can they be used to address global issues?***

Many of them may have been developed in local communities, but the Internet means they can scale globally and sustainably. I am part of a Swiss-NGO called Community Forge with over 50 community currencies, from Belgium to Bali, using free, open source software. Because it operates online, members from different countries can easily trade amongst each other.

And there's the Ven—a digital currency that represents a basket of commodities, other currencies and carbon credits. Last year it was the first digital currency to be added to Thomson Reuters, making it possible for global financial institutions to trade in it.

As you start to use alternative currencies, you sense the scarcity we experience where we struggle to make ends meet is partly artificial. It comes not from a lack of wealth in our communities, but from a mechanism of exchange based on outmoded design. Alternative currencies offer a revolutionary change we can all play a part in.

Professor Jem Bendell is the Director of the Institute for Leadership and Sustainability (IFLAS) University of Cumbria.

His latest report, 'The Necessary Transition: The Journey towards the Sustainable Enterprise Economy' can be downloaded at: [www.greenleaf-publishing.com/content/pdfs/TNT\\_bendell.pdf](http://www.greenleaf-publishing.com/content/pdfs/TNT_bendell.pdf)

Nina Rennie is the founder of Nueluxe.com





# Emerging Women Entrepreneurs and Sustainable Business in Yucatan, Mexico

*Quality, hand-embroidered home décor and clothing through women’s economic and social development*

by Isabel Peña Alfaro

Yucatan, home to the ancient Mayans in Mexico, is now confronted every day by the realities of poverty and scant education in the region. Andrea Hernández and her husband, Alejandro Legorreta, created the Fundación Legorreta Hernández to provide education, health, and work opportunities for local communities, as well as to develop sustainable business.

Their efforts and enthusiasm have driven change in Texan and Huncanab, Mayan names pronounced Tay-shán and Hoon-kah-náp, two small towns an hour’s drive from Merida, the capital city of Yucatan. In the 19<sup>th</sup> Century, Texan and Huncanab experienced a boom as the region exported henequen rope, made from the local agave and used by cargo ships. As other more durable ropes began entering the market, henequen towns fell on hard times. Since then, towns like Texan and Huncanab have been unable to reignite their economies. Today, most men in Texan and Huncanab work at nearby cement factories, while the women, most of whom have received little education, stay at home.

In response, the Foundation now provides continuing education, including computer lessons, health clinics, and fitness programs to fight diabetes and childhood obesity. The Foundation provides eye exams, glasses, and basic eye care for the people of Texan and Huncanab, who in turn participate more actively in the Foundation’s continuing education courses for those who did not finish elementary or high school. “We want to accelerate social development in Mexico through programs for kids and adults,” says Andrea.

In 2009, in an effort to restore the towns’ economic viability, Andrea and Alejandro began brainstorming ways to develop a stream of revenue for Texan and Huncanab. In 2010, Fundación Legorreta Hernández created a bee-keeping business called Muuk Kaab, “bees’ strength” in Mayan, to provide employment, initially just for

men. Once the business began in earnest, and honey orders had to be filled, the men found that they needed the help of women to keep up. It turned out that women were extremely skilled at tasks men hadn’t mastered, such as meticulously adding labels to the honey jars, as well as neatly stacking and organizing them. In light of the successful participation of women in the bee-keeping project, Andrea decided to find additional ways to get women involved.

To begin this endeavor, Andrea encouraged local women to start a business in hand-embroidered products by traveling door-to-door along with her colleagues from the Foundation, explaining that the Foundation would provide workshops to teach embroidery, so that the women could eventually sell their products in Merida. Women were curious, but most had never worked or finished school, so they doubted their ability to learn. In fact, most dropped out because they found that learning was costly and taxing; however, those who stayed named their business Chuuy ti’K’ab, “hand embroidered,” in Mayan.

Initially the Foundation jump-started the project by lending money at no interest to the women entrepreneurs. Chuuy ti’Kab is still in existence today, and the Foundation pays the women earnings from the sales, less the advance payments. The Foundation also encourages participants to save a percentage of their earnings for future orders and production, making the project the beginning of a sustainable business.

Parallel to Andrea’s efforts, another woman working with Mexican women in embroidery, Renée Niño de Rivera, was developing a sustainable fashion line made by women living in low-income Mexican communities. Renée, who was born and raised in Mexico, found that women were for the most part selling their products only to tourists, who by chance had stumbled upon their stands at the local market. She also saw that most of the shirts and shawls

were unevenly cut, with dyes that would run at the first washing. In other words, the clothing was nearly impossible to place in stores. On the basis of her experience in fashion and arts in New York, she was committed to develop links between fashion and development.

Renée began with a clothing line for young girls, embroidered by women in a remote village in the mountains of Oaxaca. With renowned painter and designer Pedro Cuní of Parsons The New School for Design in New York, Renée organized workshops in marketing and embroidery for the women in Oaxaca. The girls’ dresses that the Oaxacan women embroidered were selected for presentation at the Louvre in Paris during the 2011 *Foro de Moda Etica Latinoamericana*, organized by Adriana Marina. On the basis of that initial project, Renée continued her search for women who wanted to be part of a sustainable business, but found that there were few embroidery groups ready to participate. It was in early 2013 that Renée and Andrea met and realized they shared a desire to encourage entrepreneurship among Mexican women and concluded that it would be useful for Fundación Legorreta Hernández, Chuuy ti’K’ab, Renée, and Pedro Cuní to work together.

**The Women of Chuuy ti’K’ab** – Although Texan and Huncanab are small towns, women in the embroidery group had rarely interacted with one another before joining the classes sponsored by the Foundation. However, despite wide differences in age, the women found that each had something fresh to add to their conversations. As they embroidered, they talked about frustrations and hardships they had endured, things they had not felt comfortable expressing before. They confided in one other about mistreatment by family members, abuse, and lack of opportunities.

Their collaboration, commitment, and support for each other were made evident when they received a big order for Christmas for their place settings. They were excited; after so much investment in time, effort, and money, they were able to secure an order with a chain store in Merida, an opportunity that they would not have thought possible only a short time ago, when they doubted they could even learn to embroider. Doña Chela, mother of nine, made herself responsible for a sizeable part of the Christmas order because she wanted to provide for her children. As the deadline approached, her eldest daughter had pregnancy complications and spent many nights at the hospital in Merida. Accompanying her daughter, far from home and with little time to embroider, Doña Chela worried about the work that lay ahead. When the other women in the embroidery group heard about Doña Chela’s situation, they decided that they would split up the work among them. “After all,” one said, “we each at some point thought that we would leave the group, but we are the sole survivors of the group, so we have to help each other now.” With perseverance, they divided Doña Chela’s work, stayed up late, and took care of each other’s children while they worked. By the time Doña Chela’s new granddaughter arrived, and the Christmas deadline was upon them, their order was ready: embroidered, washed, ironed, packaged, and sent to Merida’s stores.

**Men and Family** – As the women joined the embroidery group, their husbands wondered how their wives could balance housekeeping, child rearing, and embroidering. Doña Eva, another leader of the group, said that her husband asked how she would cook and guard his store during lunchtime if she was taking lessons at the Foundation. She told him that he didn’t have to worry – she would wake up at 5:00 am in order to start cooking and cleaning before being picked up by the Foundation’s van by 7:00 am, and would be back by 1:30 pm to guard the shop. “Fine,” he said, “as long as the food is made.”

Anastacia’s husband wondered why she wanted to embroider and told her that he was worried she would leave her house duties behind. As soon as Anastacia received her first payment, she contributed to her daughters’ school expenses and bought food for the house. Anastacia’s husband became supportive. “He even learned to *iron*,” said Conchi, a young and single woman in the group. Giggling, she repeated, “The *man* irons for her! Imagine that!” “He’s become more supportive of me, and my two daughters are older, they are teenagers, so they can prepare the food. If I have to embroider, my husband will sometimes even cook!” said Anastacia. This is a rarity in Texan, but things are changing slowly as some young women join the workforce in nearby cement factories and homes.

**Educating Entrepreneurs** – Pedro Cuní’s art and embroidery workshops in Texan and Huncanab are complemented by Renée’s marketing and sales courses. Pedro encourages self-expression, self-discovery and attention to detail in all of his students: whether at Parsons in New York, or in Yucatan. He tells the women in Yucatan that every intricate curve and shadow contributes to a complete design.

Renée encourages the women in Chuuy ti’K’ab to consider themselves as a business. “I am talking business woman to business woman,” Renée said at the outset of her marketing class in the Foundation’s classroom. As part of her first marketing lesson, she flashed a picture on the screen of Pippa Middleton walking through the streets of London, followed by a picture of a table with crystal glasses, silk place settings, and silver cutlery. “Now, let’s pretend this is our client. We want to constantly ask ourselves: What would she like in her home? What can I offer that is different from my competitors?” said Renée. She continued flashing pictures on the screen and said, “Let’s begin the exercise. What can I make for this client?” Conchi with her youthful spirit said, “The pillows for the sofa.” Still quiet, the rest of the women watched the screen. One woman commented, “I’ve seen these in settings in the *telenovelas*, but never thought that we could sell things like that.” In a soft voice, one said, “Napkin holders?” Then others started chiming in. As Renée kept flashing pictures across the screen, the women voiced their ideas: table settings, placemats, napkins. What began as tentative suggestions became viable ideas of true entrepreneurs.

**Working Towards Sustainability** – The hard work of taking those dreams to market has begun. The hope is that, complemented by the health and education clinics of the Fundación Legorreta Hernández, each woman’s family will attain a better quality of life. Real change will be slow. With her eyes fixed on her embroidery and her hands steady on the thread and needle, Anastacia, who only reached the third grade, commented, “My brothers went to school, but I had to stay home because I wasn’t allowed. This project brought school to me.”



Isabel Peña Alfaro is a public relations professional focused on multicultural branding at Edelman in New York City.

[www.fundacionlegorretahernandez.org](http://www.fundacionlegorretahernandez.org)  
[www.reneeninoderivera.com](http://www.reneeninoderivera.com)





## Harnessing Luxury Spending Power

*to uplift some of the world's most impoverished children, sustainably*

by Nina Rennie

Almost everyone who travels internationally comes into contact with the many desperately poor children who beg, sell, and spend their lives on the streets. As one moves between airport and hotel, tightly clutching bags, giving money seems like the only way to help, even though experts will tell you this actually only perpetuates the cycle. But what if the branded possessions we hold in our hands, and the stylish places in which we stay, could tangibly improve the lives of the 100 million children that UNICEF estimates are currently struggling to survive on the world's streets?

In quickly-developing Brazil, demand for luxury goods and services is accelerating. At the same time, an ever-increasing number of children struggle to survive the squalor of their daily lives. One fashion label continues to fight this shocking paradox by linking the two extremes in a mutually beneficial way.

Salvadorian Luciano Dos Santos has partnered with Bottletop since 2009, the label created by Cameron Saul (son of the luxury brand Mulberry's founder). In their favela-based atelier, a team of previously unemployed women handcrafts belts and bags that regularly grace the pages of glossy fashion magazines and the arms of style icons such as Kate Moss. It is difficult to believe objects of such high quality craftsmanship have been crocheted from recycled materials such as aluminium ring-pulls. However, the most incredible aspect of this venture is the social impact.

The label's sales raise funds and awareness for the work of the Bottletop Foundation. The organization empowers over 35,000 young people each year in Malawi, Mozambique, Rwanda, Brazil, and the UK through creative health and education projects. Another emerging 'sustainably luxe' brand, Angel Jackson, also believes in combining design-led craftsmanship with a social mission. Sold in prestigious department stores such as Harrods, their handbags and accessories are handmade, using ethically sourced materials from their fairtrade standard workshop in Bali. The team is collaborating with the Sacred Childhoods Foundation on a new collection to raise awareness and funds for work with children born into abject poverty.

Meanwhile, the 'Mums in the Slums' training scheme is teaching women how to handcraft accessories to international market standards using leather offcuts and spares from the Angel Jackson factory, enabling local women to support their families and send their children to school. The Sacred Childhoods Foundation founder Natalia Perry explains that when it comes to poverty, "charity is just a band-aid, a small, short term solution to a difficult problem. Sustainable businesses that support the true needs of disadvantaged communities have a far greater potential to change lives for the better, forever." This heartfelt belief in sustainable development is shared in Laos, where Laotian scientist and award-winning community leader, Sombath Somphone, established the indigenous PADETC (Participatory Development Training Centre) organization based on the Principles of Education for Sustainable Development and 'a balance between social development, economic development and environmental harmony.' Having worked his entire life to help local youngsters break free from the poverty he was born into, he saw great potential in an enterprise partnership that elevates traditional craftsmanship and empowers villagers economically. Orijyn's handmade jewelry and silk scarves are created using centuries old techniques once reserved for the royal family. Profits go to PADETC's work, providing vocational training and hope to young students in a country ravaged by decades of war.

In equally economically unstable countries, some of the most inspiring and impactful partnerships enable tourists to stay in places that directly help the children living in hardship outside the hotel walls. Saddened by the street children she encountered in the Incan capital of Cusco, Peru, Jolanda Van de Berg decided to devote her life to helping at least one. Over 15 years later, profits from her three elegant hotels go to the Niños Foundation, providing comprehensive care and education for 600 street children a day. Van de Berg works towards alleviating the poverty that led to the youngsters being on the streets in the first place. The hotels engage local suppliers and workers, many of whom are relatives of the rescued children.

The holistic Niños educational program includes vocational training when the students become teenagers so they learn the hospitality trade themselves. In Mozambique, a country rich in natural resources, one in three children die before their fifth birthday. Guludo lodge was created there to change this statistic and show how sustainable luxury tourism can be used to reduce poverty and empower local communities in a sustainable way. Guludo's 'Nema' Foundation partners with 16 local communities to implement a range of health, water, education and enterprise projects. Together they work with 150 local suppliers and craft businesses, employ more than 70 staff and provide school meals for 800 malnourished children, sponsor secondary school scholarships for 129 scholars, and build schools from scratch. In nearby South Africa, at the Kuzuko Lodge, payment for one's stay contributes to the funds needed to keep all local children in school, as well as supports the surrounding game reserve that was brought back to life. Kuzuko has also adopted orphans like Freddie (pictured), who has grown up to become a resident gamekeeper and now teaches younger members of the Kuzuko 'family' how to preserve the environment. This triple bottom line business ethos underpins the International Trade Centre's Ethical Fashion Programme and their partnerships with the likes of Vivienne Westwood. Previously unemployed women, many of whom are mothers, have become dignified artisans and thousands of slum-dwelling families have benefitted from the production of 'upcycled' fashion goods which have a unique appeal for conscious consumers.

As CSR (Corporate Social Responsibility) rises higher on the agendas of global luxury brands, and more charities employ business principles to end dependency on donations, it seems both groups could learn from these lesser known sustainably lux ventures whose raison d'être is high end for high impact. As the gap between rich and poor widens, 'it is likely that the numbers (of street children) are increasing' (UNICEF). The urgency is clear. Tapping into the exponential growth of luxury spending, with sustainable products and services, could be key to channelling money from the most privileged to where it is needed most: in the lives of the children who have fallen through the cracks in society.

Nina Rennie is the founder of [nueluxe.com](http://nueluxe.com) and a contributor to a variety of publications and consciousness-raising campaigns.

Photo of Freddie, at the Kuzuko Lodge, by Paula Harrowing.

## A Creative Key to Success—Raymond Choy and the Qee



Qee. TM & © Toy2R Limited. All rights reserved. All intellectual property rights in Qee are owned by Toy2R Limited.

by Samuel Weinberg



With insatiable fan-bases and fierce competition, the challenges for entrepreneurs in the toy market are numerous, not least in Hong Kong, where Raymond Choy was born and embarked on his career.

Choy's entrance into the world of collectable toys was one of both creativity and inherent risk. Choy, always an entrepreneur at heart, at a young age left a stable occupation in the shoe business and opened a toy store. Choy, immediately, took his ambitions one step further with his company Toy2R. He produced toys with themes that were previously taboo, demonstrating that he was not afraid of being progressive and provocative.

In the late 1990s a vinyl renaissance occurred in Hong Kong. Raymond Choy was at the heart of the movement, releasing his signature "QEE collection." The QEE was, from the start, highly collectable. What set it apart from similar products was Choy's direction and vision. Whereas many creative designers moved into replication of already well-developed fan-fiction universes such as Star Wars, Choy sought out to carve his own kingdom. Both fan-fiction and logo based QEEs, such as the Adidas collection, were produced, but many were individualized, thanks to direct and multifarious collaborations between Choy and creative minds around the world.

In a bold move in 2002, shortly after the QEE's initial release, Choy, with a dozen 8-inch plain QEE figures in tow, set out on a journey to meet with ten choice designers. He then went on to promote a broader base of artists through his product, traveling continent to continent, displaying the designer series.

The QEE design was not limited to renowned artists in the field of toy design only, such as Voltaire and Mad Barbarians. In keeping with the theme of collaboration and hands-on design, Raymond Choy released the DIY QEE. The totally blank QEE is interactive, enabling the users to send images of their own design to Toy2R. Encountering great interest from the start, the DIY QEE quickly became a vehicle for creative talents to express themselves and garner recognition. A number of these individuals' works have been featured in collections.

With the fan-made QEE, Choy transformed consumers into designers, and evolved Toy2R from a company and a brand into a forum for ideas. True to the spirit of the entrepreneur, the DIY QEE presents an opportunity to look beyond appearances and explore unlimited possibilities for creative expression, communication, and even philanthropy...as when an 8-inch hand painted Brain Pattern Qee helped raise funds for the Foundation Against Aids at the SWAB, Barcelona auction hosted by Sotheby's.

The success story of Toy2R has been acknowledged by multiple awards and was featured among case studies at the Ivey School of Business of the University of Western Ontario and Harvard Business School. Thus, the QEE has become more than just a toy. More than even a form of a collectible, it has become what its name so aptly calls it: a key to success.

Dr. Choy is the 2013-14 President of the Lions Club of Hong Kong (Pacific), a government-recognized charity and partner organization of World Council of Peoples for the United Nations.

[www.toy2r.com](http://www.toy2r.com)  
Info@toy2r.com





# Wings of Hope: Beyond Agendas

by Douglas Clements

All of us humans share the common need of a basic level of healthcare. We are much more fragile than other animals. After 51 years, Wings of Hope has developed a broad concept of what healthcare entails. It isn't as simple as having access to a doctor when we are sick.

Staying in good health requires sustainable food and water and basic education, so we can read and understand processes for leading a more healthful life...an ability to secure good rest, and the time to allow our bodies to heal. And of course, access to a simple system for obtaining the care of some sort of medical professional when the education and sustainable sustenance fail us.

The work of Wings of Hope spans 47 countries and 157 Bases of Operation. Each is customized to suit the societies we serve, the existing governmental systems and the issues confronting the people within a region. Our work is almost always from the bottom up, rather than the top down. We devote resources to where they are needed and provide ongoing guidance and assistance until success is achieved.

We consider each group of people we are serving as Sovereign and unique. They have rights, cultures and habits that are theirs alone. We not only respect their distinctive attributes, we honor them. We do not do things they do not wish us to do. We do not tell them their way of life, or way of thinking is wrong. We simply try to answer their laments with all the options that may be available. We also explain the pros and cons of those options, the ramifications of implementing them and their viability.

Then it is up to them. We respect their choices and work hard to help them achieve their dreams, not our dreams.

There have been cases when the local people decide not to do anything because they did not like the choices and ramifications of any of the options. As an example: Some tribal groups are very traditional in their roles of men being hunters and women being gatherers. When the option for better nutrition includes raising some sustainable plant and animal sources of food, they may decide this change has too drastic of an impact on their lifestyle. That is perfectly acceptable to us. We will still stand by them and assist in whatever capacity they wish. All of our work follows this same basic precept.

This philosophy of how we work is, in our mind, the way we should treat our fellow man. We do not come to them with an agenda of any sort—not religious, or political, or related to ethnicity. We are not there to 'plant our flag' of what is right or wrong. We simply come to them and ask how we can assist them.

Because of the broad nature of our work, we usually can address almost any issue and design something that meets with the approval of all concerned. Our focus is fixed on how to help people achieve their goals. No subject is too abstract or too complex and no situation hopeless. We are fortunate to have over 3,000 worldwide volunteers who are able to address essentially every subject that may be encountered. These volunteers are also extremely adept at cutting through red tape (regardless of the source of that bureaucracy) and accomplishing desired goals to help the people of a region begin their journey to where they wish to be.

Examples of our work are numerous, but there is one common denominator to all of them: We show up with kindness and listen. The many regions of the world we work in need assistance; that is why they asked us to come. But they do not need someone giving them orders. They just need the tools they lack and the teaching so they can tackle their issues by their own volition.

While we humans are more fragile than most other animals, we are immensely more creative. We can usually solve our problems with the right tools and intentions. Wings of Hope just listens to what the people need and provides them with the resources to begin their journey to Peace and Hope.

*Photo: Wings of Hope has landed on a road in Nicaragua. Everyone crowds around the plane to see what supplies have been brought. Courtesy of Wings of Hope.*

Douglas Clements is the President of Wings of Hope.  
woh206@earthlink.net  
800.448.9487  
636.537.1302

[www.wings-of-hope.org](http://www.wings-of-hope.org)





## Sustainable Development, as an Idea

by Ebi Spahiu

I moved to Bishkek, Kyrgyzstan, in January 2013, to work for an access to justice program supported by the Finnish Foreign Ministry and teach a human rights/legal English class at two major national law schools. At the outset of the course, my goal was to present the curriculum I had developed from scratch and to communicate that this wasn't going to be a simple language class; it was going to be a human rights class. We were going to discuss social issues, deconstruct ideas and match them to their corresponding legal implications; we were going to address the social struggles of vulnerable people—groups of individuals discriminated against because of their gender, age, ethnic identity, and sexual orientation, among other factors. But I soon came to understand that, apart from language limitations, most students had never taken a critical thinking class, and legal reasoning had never been part of their syllabus. The terminology, material, and Western-based teaching style I was using didn't resemble any other form of legal literature they had come across before, provided they had any familiarity with legal literature at all. Apart from changing my expectations, I now had to think of different

approaches that would achieve my objectives for the class. This, along with other experiences I've had as a young "development professional" in the field, has led me to reevaluate the work I and others in similar situations carry out: its purpose and whom it's serving. For sustainable development projects to have continuity, we need to develop ideas that resonate with the local communities and are adapted to their mindset. While this approach is increasingly popular in theory, it's very slow to be implemented.

During one of my first few lessons, I asked my students if they knew the meaning of the word "vulnerable." Not one student knew what the word meant and why it was important for the class. After all, unless one is proficient in English, the likelihood that one can translate "vulnerable" into Russian or Kyrgyz is very slim. I then gave them a simple explanation they could visualize: "weak, exposed to danger or risk, like a baby left out in the cold without being fed or clothed. The baby would be considered to be in a vulnerable state because he/she has been left outside with no protection."

"Then what makes an individual strong?" I asked them. I began listing their answers on the blackboard: a home, love, a good job, knowledge, education, weapons, religious beliefs, family, friends, hobbies, purpose, passion, values, talent, good health, an identification card, culture, and national history, were among the answers that filled the large blackboard.

I then erased everything from the board and asked them to identify the groups of people that are deprived of these elements. It was easy for them to point out women, orphans, people with mental or physical disabilities, the infirm, ethnic, racial or religious minorities, people living in poverty, immigrants, migrant workers and, at the end, one voice even dared to include gays and lesbians in the groups of individuals considered to be vulnerable. The room fell silent as I was avoiding discussing any controversial matters that had just been displayed on the board. I wanted the students to sink into their thoughts and reflect, but my wishful thinking quickly fell through when the discussion turned from human rights to what religion allows and their national traditions uphold. The students speaking their minds were bright future lawyers that will represent their country's constitution and memorize the legal codes that fully protect the rights of those discriminated against—be they gays and lesbians banished by their religion, or the thousands of women recorded to be kidnapped for marriage and who fall victim of domestic abuse each year in Kyrgyzstan, as in many other countries. However, during our discussion, and because of my persistence to hear them develop their argumentation, most referred to their traditions, religious beliefs, and national identity as the pillars that are best suited to ensure social justice, rather than the laws that are designed to protect the most vulnerable.

As a person born in Albania, raised in China, who has studied in the US and is now working in Kyrgyzstan, I have long reflected on the conflicts between liberals and traditionalists when it comes to the moral value of human rights, and on the lack of impact legal protection mechanisms have on traditionalists, who often justify abuse or discrimination in the name of culture, national identity, and religious beliefs. During many interviews with beneficiaries of our legal aid program—most of whom were women, victims of domestic violence, or women of different ethnic minorities—they stressed that prior to our interventions they had been unaware of

the rights addressing their concerns. To them, legal awareness was a sigh of relief, a means of escape from the accepted traditional beliefs that they should suffer because of their identity or position.

Nonetheless, for many others, legal awareness and action to address situations of discrimination or abuse, amount to a stain on one's family honor and an intrusion of Western ideas into traditional beliefs and codes of honor that shape life as they know it. The responses are unwelcoming to the values of human rights for which most aid programs and international development projects advocate.

Looking through articles and commentaries by development professionals disappointed by the lack of significant results in the communities they passionately serve, there appears to be momentum for development projects to become more inclusive of local traditional actors, involving them in the decision-making process, be they religious leaders or community elders, so as to address the needs of local communities rather than just the desired outcomes of donors. Yet, today's sustainable development approach is still a political form of thinking, which addresses local issues, but most often disregards the communities' entrenched cultural environments.

The rhetoric behind sustainable development has generated numerous programs in a wide range of areas, some of which are successful, but measuring levels of sustainability remains a hard task for most aid workers. Once the programs' time frame is completed, funding is not guaranteed for the local individuals who have carried out the projects to continue the work when the internationals leave. Sustainability can only function if it becomes an idea rather than a political process. For any such effort to endure in a weak political environment, these development programs must become more than a political mechanism for government leaders to ensure funding, and instead be communicated as an idea that makes sense in the local community's language and thoughts.



Photo on opposite page:  
Women praying at the Suleyman Mountain in the southern city of Osh, the only World Heritage Site in Kyrgyzstan.

Photo on this page: Eid prayers in Bishkek.

Ebi Spahiu is a consultant for the Eurasia Foundation and Eurasia Foundation of Central Asia office in Bishkek, Kyrgyzstan on the Equal Before the Law: Access to Justice in Central Asia program funded by the Finnish Foreign Ministry, and teaches Legal English at the Kyrgyz State Law Academy and Kyrgyz National Institute.

[www.flickr.com/photos/ebispahiu](http://www.flickr.com/photos/ebispahiu)  
[www.ebispahiu.tumblr.com](http://www.ebispahiu.tumblr.com)  
[www.walkingonthesilkroad.wordpress.com](http://www.walkingonthesilkroad.wordpress.com)





Can visual storytelling help build a better world? What must media makers interested in dedicating their work to positive change think about beyond creating media? In the digital age, what are the opportunities for engaging audiences in envisioning a bright future for all?... these are some of the questions that propelled the *One Water* project at the University of Miami more than 10 years ago. The work continues with the current project *On Cities*.

Drawing inspiration from a quote from World Bank's Ismail Serageldin "...if the wars of this century (20<sup>th</sup>) were fought over oil, the wars of the next century will be fought over water..." we began work on *One Water* in 2002. Our team at the University of Miami was not really interested in bringing all the relevant information about the past, present and future of water on the planet. Rather, based on travel and ongoing interactions with communities in various parts of the world we wanted to visually explore our changing relationship to water. Our project intended to share human experiences rather than disseminate specific information.

Water is everywhere and we seem to take it for granted. How could a film help people look at water differently, perhaps more closely? The first 22-minute version of the film had no words, only compelling visual sequences, natural sounds and an original orchestral score. The idea was to utilize this short film to engage other media makers and journalists to create more stories about water. In this effort, we created video contests, journalism opportunities, and through a partnership with San Francisco based Independent Television Service (ITVS), we were able to partner with national broadcasters in Bahrain, Colombia, India, and South Africa to create four hour-long documentary films focused on water issues particular to those countries.

Over a period of six years our film *One Water* spawned other versions: A multi award-winning feature version (67 minutes) that

featured interviews with world figures including Vandana Shiva, Robert Kennedy, Oscar Olivera Foronda, and the Dalai Lama, among others; a concert version (28 minutes) that was prepared exclusively for live concert accompaniment by orchestras and was performed at venues such as the Kennedy Center and the Fort Lauderdale Center for the Performing Arts; a broadcast version (52 minutes) of *One Water* narrated by Martin Sheen was created for international distribution and to date has reached an estimated 340 million households worldwide.

All of the above was of course made possible by the participation and support of many creative people around the world and by the generosity of others who found the effort to be worthwhile. The John S. and James L. Knight Foundation provided major support not only to finish production of *One Water*, but also towards the creation on the Knight Center for International Media at the University of Miami as an engine for similar efforts to bring international attention to issues of global significance.

*On Cities* is the second project following *One Water* that was officially launched in 2012 with a virtual event that connected 30 locations around the world around three short, non-verbal films intended to spark discussion around the past, present and future of cities. The nature of the media experiment this time around focuses more directly on creating a network of media change makers to mount a project focused on urban innovations that help improve life in cities.

Through visual storytelling contests, workshops on urban story telling, and negotiating distribution opportunities for work created by emerging mediamakers in cities, we are working towards the creation of a network of mediamakers interested in telling stories of positive change.

# "I'm Design Thinking About You"

*Or why collaborating with designers can bring you unexpected benefits*

by Gala Narezo

In 1966, when Buckminster Fuller invited the public to engage in The World Game and "raise the standard of living for all," he was presenting the ultimate design thinking challenge. Design Thinking, also referred to as transformation design, design for good, innovation design (and the list goes on), is a problem solving methodology used by designers and others trying to maximize creativity and innovation. Often used when approaching intractable, real world, social issues, referred to as "wicked problems," designers use all the skills available to them to reach unexpected solutions through a series of rigorous steps. Design Thinking projects often involve numerous partners, communities, or stakeholders, extensive research and dialogue, ethnographic studies, thousands of post it notes, ideation, copious iterations, more dialogue, lots of documentation and, finally, products, events, interventions, solutions, and results. Key concepts in this field include an understanding of context and a human centered perspective. Empathy is essential.

Is Design Thinking different from what you are already doing? The truth is that it might not be, but it probably is. When trying to solve a "wicked problem," we need all the help we can get. You are probably already doing all the things that you know how to do as well as you can. Designers are trained to look, listen, craft, narrate, brand, communicate, create, recreate, influence outcomes, and change behaviors. The sheer act of inviting an outsider into your process is often very fruitful.

Recently a tool called *The Social Design Pathways Matrix* was created to illustrate how designers work with partners to address social issues and what kind of results can be expected. Following is a description of how it works written by Charlie Cannon:

"The Social Design Pathways matrix is a useful tool for clarifying the terrain, stakeholders and potential impacts of social design projects. It acknowledges the fact that design for social impact, as an emerging field, can be complex and multi-dimensional, and that a process for mapping its many ingredients can be instructive and beneficial. The matrix can help reveal the skills required for action, the kinds of participants and partners required for rigorous work, the scales of engagement, and the possible outcomes for a given social impact challenge. Problem solvers can use the Social Design Pathways matrix to see the distant but clear edges of the total landscape of social design practices, to expand their perspective, and to inform the solution strategies that they choose to pursue."

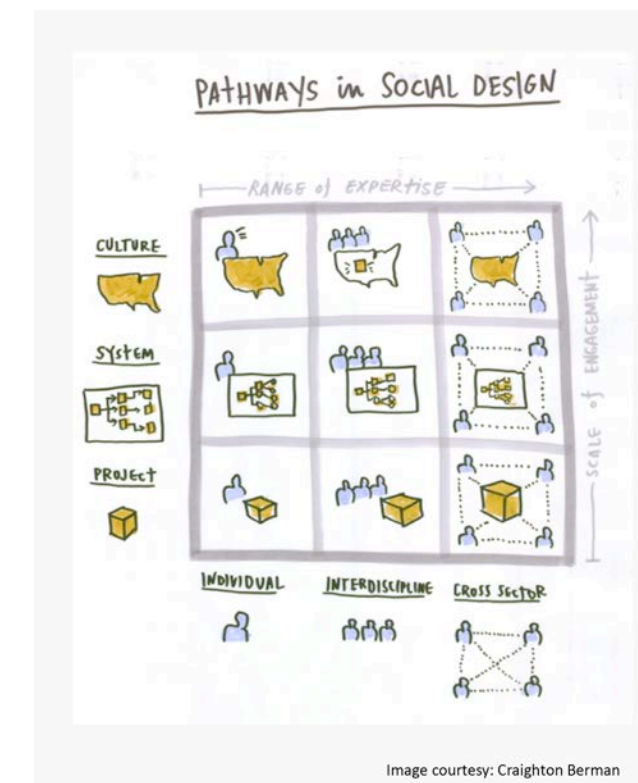

The Social Design Pathways matrix was developed at the 2013 Winterhouse Symposium for Design Education and Social Change. This work is licensed under Creative Commons Attribution 3.0 Unported License (a [http://creativecommons.org/licenses/by/3.0/deed/en\\_US](http://creativecommons.org/licenses/by/3.0/deed/en_US)), meaning you can use it any way you wish as long as you attribute it and share any alterations or use of the matrix with us (and other users) by emailing: [socialdesignpathways@gmail.com](mailto:socialdesignpathways@gmail.com)

Gala Narezo is an artist, activist and educator. She specializes in creating platforms for social issues using design thinking, mindfulness and storytelling.

[www.galanarezo.com](http://www.galanarezo.com)  
[www.whatmovesyou.net](http://www.whatmovesyou.net)  
[www.indocumentales.com](http://www.indocumentales.com)

Photo of São Paulo (one of the cities chosen for the *On Cities* project) by Sanjeev Chatterjee.

Sanjeev Chatterjee is a teacher and mediamaker focusing on global documentary work. He was the founding Executive Director of the Knight Center for International Media at the University of Miami and served as the Vice Dean of the School of Communication, University of Miami during the same period. In 2011, Sanjeev spent 6 months in India as a Fulbright-Nehru scholar. His interests include interdisciplinary collaborations that will incubate global multimedia documentary projects aimed at positive change.

[www.knight.miami.edu/report](http://www.knight.miami.edu/report)  
[www.onewater.org](http://www.onewater.org)



# BioGeometry: The Science that Should Shape our World

by Ahmed Tarek Wafik, M.S.

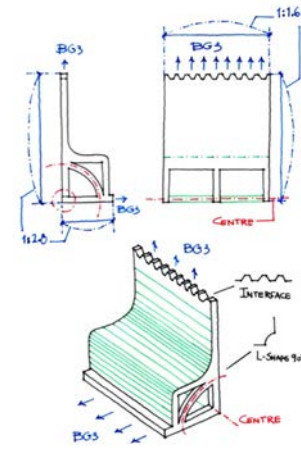

Sketches:  
Outdoor bench and Bus stop designed using BioGeometry design principles.

Ahmed Tarek Wafik is an architect and urban designer. He holds a B.A. in Architecture and M.S. in Urban Development & Community Design from the Faculty of Engineering, Cairo University, Egypt.

wafik.a.t.designs@outlook.com  
www.biogeometry.ca

As an architect and urban designer I have always valued shapes, as they are the fabric of my craft. Yet, I never imagined that a shape could have a physical and psychological impact on human welfare. That changed when I came across the science of BioGeometry, revered by many as “the science of miracles.”

BioGeometry is a new science founded by Egyptian architect and scientist, Dr. Ibrahim Karim. It is based on a Physics of Quality, which deals with characteristics of environmental energy. This science introduces a design language, utilizing the energy principles of geometrical shapes to balance biological energy systems within our environment. In order to do this, BioGeometry encompasses universal laws and natural dynamics affecting living energy systems, which have been largely ignored by modern civilization at the cost of our health and overall wellbeing.

Evidence indicates that the geometrical shapes that BioGeometry creates have a uniquely positive influence on human health, as well as a phenomenal effect on water molecules and crystals, as proven by Dr. Masaru Emoto. These findings and others sparked great interest among international scientists and researchers. Consequently, numerous studies are now being conducted worldwide on the benefits of BioGeometry in various fields. Results have shown that BioGeometry has succeeded in providing solutions, namely with regard to modern-day problems related to electromagnetic fields and radiation (EMFs & EMR) emitted by cell phones, cell phone towers, high voltage power-lines/station, and radars.

As dependency on devices, which emit these EMFs/EMR, increases, our living and working spaces are becoming oversaturated with their harmful emissions. Even the World Health Organization has recently declared that, “*Electromagnetic fields of all frequencies represent one of the most common and fastest growing environmental influences, about which anxiety and speculation are spreading. All populations are now exposed to varying degrees of EMF, and the levels will continue to increase as technology advances.*” Indeed, multiple studies have established linkages between EMFs & EMR and illnesses such as brain tumours, leukaemia, breast cancer, as well as other health problems including sleep disorders, anxiety, depression, stress, vertigo, headaches, miscarriage, fatigue, and hyperactivity and lack of concentration in children.

BioGeometry has been especially successful in eliminating the negative health effects caused by short-term exposure to EM sources. This achievement was widely publicized by the Swiss government and media as “The Miracle of Hemberg & Hirschberg:” In 2002, the Swisscom telecom company installed a cell phone antenna station in the remote town of Hemberg, Switzerland. This

had a strong negative impact on the residents of the town, who were used to living in a natural and virgin environment. Almost all of them suffered from sleep disorders and some had severe health issues that they had never before experienced. The people blamed the newly installed antenna for their health problems. In addition, they reported that some types of birds disappeared from the area and that certain plants were no longer thriving. The problem was widely publicized, putting pressure on the telecom company and the government to address the matter. Dr. Ibrahim offered BioGeometry as a solution, placing specially designed BioGeometrical shapes in the context of the cell antenna and in the houses of some of the residents who were severely suffering from the antenna’s radiation. Within a few days, almost all the residents reported sleeping better and, over time, their health problems disappeared. It was very clear to the residents and all parties involved that these BioGeometrical shapes solved their electromagnetic problem. Similar BioGeometrical solutions were implemented in the town of Hirshberg, Switzerland after a new cell antenna was installed there. The results were equally successful in battling the harmful EMFs.

These two projects demonstrating the effectiveness of BioGeometry in eliminating negative side effects of short-term exposure to EMR have prompted new research on the long-term potential of BioGeometry in reducing the development or growth of cancer cells.

The implementation of BioGeometrical designs is expanding to many fields including that of architecture and interior design. Designing buildings, furniture and fixtures using BioGeometry will create mega BioGeometrical shapes that reinforce healthier energy qualities in our living spaces and environment. As a BioGeometry designer, my commitment is to apply BioGeometry to urban, public spaces—the most significant spaces in a city, visually, formally, functionally and energetically—in order to yield positive impacts for the public at large.

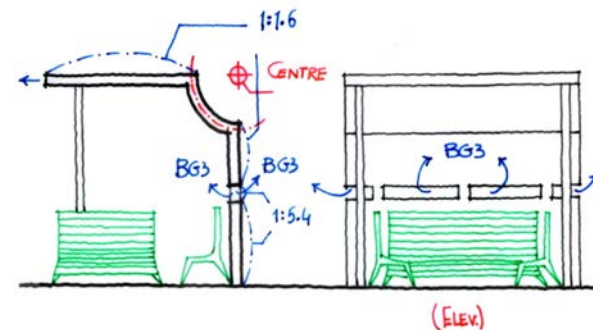

## Masdar City Abu Dhabi, United Arab Emirates Foster + Partners

Masdar City combines state-of-the-art technologies with the planning principles of traditional Arab settlements to create a desert community that aims to be carbon neutral and zero waste. The 640-hectare project is a key component of the Masdar Initiative, established by the government of Abu Dhabi to advance the development of renewable energy and clean-technology solutions for a life beyond oil. The city will become a center for the advancement of new ideas for energy production, with the ambition of attracting the highest levels of expertise. Knowledge gained here has already aided the development of Abu Dhabi’s ‘Estidama’ rating system for sustainable building, and post-occupancy environmental studies have demonstrated the efficacy of the Foster + Partners masterplan in reducing felt temperatures and prolonging the moderate season in the city.

A mixed-use, low-rise, high-density development, Masdar City includes the headquarters for the International Renewable Energy Agency and the recently completed Masdar Institute. Strategically located for Abu Dhabi’s transport infrastructure, Masdar is linked to neighboring communities and the international airport by existing road and rail routes. The city itself will be the first modern community in the world to operate without fossil-fuelled vehicles at street level. With short distances to rapid transport links and amenities, the city is designed to encourage walking, while its shaded streets and courtyards offer an attractive pedestrian environment, sheltered from climatic extremes. The land surrounding the city will contain wind and photovoltaic farms, research fields and plantations, allowing the community to be entirely energy self-sufficient.

The development is divided into two sectors, bridged by a linear park, and is being constructed in phases, beginning with the larger sector. The masterplan is designed to be highly flexible, to allow it to benefit from emergent technologies and to respond to lessons learned during the implementation of the initial phases. Expansion has been anticipated from the outset, allowing for growth while avoiding the sprawl that besets so many cities. While Masdar’s design represents a specific response to its location and climate, the underlying principles are applicable anywhere in the world. In that sense, it offers a blueprint for the sustainable city of the future.

Lord Foster: “Masdar is an ideal pattern in the sense that it is high density and pedestrian-friendly, rather than designed around the car and the unsustainable urban sprawl that this leads to. However, every model of urban planning must be a specific response to its location, climatically and culturally. With Masdar, we are attempting to create a low carbon city in the desert, one of the most extreme inhabited climates on earth. There is a sense that if we can do it here we can do it anywhere—the lessons we are learning certainly have applicability for cities around the world.”

The Masdar Institute is the first part of the wider masterplan to be realized and creates an educational focus for the entire programme. The Institute is the first building of its kind to be powered entirely by renewable solar energy and incorporates a variety of passive and active environmental strategies. It is conceived as a test-bed for the sustainable technologies that will be explored for implementation in future Masdar City buildings.

The Institute’s residences and laboratories are oriented to shade both the adjacent buildings and the pedestrian streets below and the facades are also self-shading. Over 5,000 square metres of roof-mounted photovoltaic installations provide power and further protection from direct sunlight. A 10-megawatt solar field within the masterplan site provides 60% more energy than is consumed by the Masdar Institute, all of which can be fed back to the Abu Dhabi grid. The campus will also use significantly less energy and water than average modern buildings in the UAE. Horizontal and vertical fins and brises-soleil shade the laboratories, which have highly flexible ‘plug and play’ services to encourage interdisciplinary research. The laboratory facades are formed from highly insulative inflatable ETFE cushions, which remain cool to the touch under the intense desert sun. Cooling air currents are directed through the public spaces using a contemporary interpretation of the region’s traditional wind towers, and green landscaping and water provide evaporative cooling.

The laboratories and residential accommodations are supported by a variety of social spaces, including a gymnasium, canteen, café, knowledge centre, majlis—or meeting place—and landscaped areas that extend the civic realm. One, two and three-bedroom apartments are housed in low-rise, high-density blocks, which provide a social counterpoint to the research environment. Windows in the residential buildings are protected by a contemporary reinterpretation of mashrabiya, a type of latticed projecting oriel window, constructed with sustainably developed, glass-reinforced concrete and colored with local sand to integrate with its desert context and to minimize maintenance. The perforations for light and shade are based on the patterns found in the traditional architecture of Islam.

www.fosterandpartners.com







# Serve: The Ultimate Black Book Vol.1

by Zoe Himmel

Black books are the unseen graffiti world where writers play with ideas before executing them in paint. The books are personal and private, but they also form a community because writers trade books to inspire and compete with each other. Graffiti may be an international commercial phenomenon, but most people have never seen these black books and know little about how the art is made.

Serve (Joey Vega) is one of graffiti's biggest names, a writer who first achieved fame doing trains and black books in New York City during the glory days of the 1980s. He began drawing at the age of three with a gift for expressing himself through images.

Growing up in the South Bronx during the 1970s, Serve came of age during the golden era of New York City graffiti, and he was perfectly placed to capture its essence. Serve got his start hanging around the original masters at the infamous Writers Bench in the 149<sup>th</sup> Street Grand Concourse subway station. The 1980s was an intense time for graffiti with so much innovation and competition, but Serve quickly made a name for himself on trains and in black books across New York City. Serve was especially known for going beyond traditional graffiti lettering to draw intricate characters and vivid scenes injected with social commentary that depicted the world around him.

In the 1990s graffiti shifted away from trains, and Serve took his talents in new directions. Music was one outlet as Serve had been DJing since the 1980s, and by the 1990s he was in permanent rotation at some of the hottest New York nightclubs like Tunnel and the Palladium. From 1989 to 2012 Serve also spread his fame doing artwork for over 40 album covers.

*The Ultimate Black Book Vol. 1* (Tuff City Styles) provides an intimate window into the world of graffiti with dazzling masterpieces from the black book of a living legend.

Art:  
*Salsa* (2011) is a tribute to  
Serve's favorite Latin artists.

Serve170.com  
TuffCityBooks.com



“It’s not just about what we’re learning, it’s also about who we’re learning from and who we’re learning with.”

- A Dialogue with author, Rhodes Scholar and combat veteran,

# Wes Moore

What are the conditions for sustainable development at the level of communities, families and individuals? CENTERPOINT NOW invited Wes Moore, author of *The Other Wes Moore*, to comment on the circumstances that separated his trajectory from that of a boy who shared the same name and grew up in a similar Baltimore neighborhood, but whose path would lead him to multiple incarcerations and ultimately a life-sentence for murder.

**CENTERPOINT NOW (CPN):** In your book you describe how “the other” Wes Moore’s mother, Mary, hid a letter from Wes which explained that “the federal budget for Basic Educational Opportunity Grants—or Pell Grants—was being slashed, and her grant was being terminated.” You also mention, “Later in life I learned that the way many governors projected the numbers of beds they’d need for prison facilities was by examining the reading scores of third graders.” Your parents were educated and were ultimately able to find the resources through their personal support system to send you to private schools. For the other Wes, this was not the case. It may be impossible to determine if Wes Moore’s story would have evolved differently had Mary been able to complete her college education, but one can’t help but speculate....

**Wes Moore:** We need to understand the importance of access to higher education environments for people who are living in lower income at-risk situations. People tend to think about education being important because of what we’re learning. That’s part of it, but it’s not just about ‘what’ we’re learning; it’s also about who we’re learning from, and who we’re learning with. Those factors are some of the joys of education, and these two stories clearly show their impact. I can’t help but think of how different life would have been for Wes and his mother had she had a chance to finish college. It’s much more than a piece of paper, much more than a degree. As you move up in higher education, your networks expand, your friendships and connections change. Every single one of us has benefited just as much from the people we met while being educated, as we did from the actual educational platform.

**CPN:** At one point you recall your first experiences taking the subway upon moving to New York and your friend’s advice about how to get a seat, “Just stand next to the white people. They’ll get off by a Hundred and Tenth Street.” This geographic segregation would probably hold true today, some 25 years later. You recall your difficulty in belonging to two worlds and describe a failed attempt at bringing your private school friends together with friends from your neighborhood. Do you think it’s important for populations of different color, ethnicity, and income to interact? How could this be done in a way that is not contrived and doesn’t reinforce divisiveness?

**W.M.:** It’s not important; it’s imperative. Any time you have lack of understanding, you have stereotyping. The stereotyping is equally vicious on both sides. When people don’t know one another, they

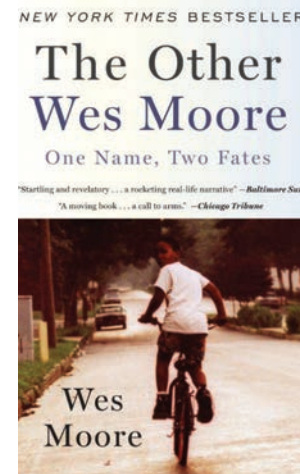

don’t understand context and use the simple recourse of coming up with prejudice about people’s identity and how they manage to achieve certain things.... These prejudices then translate into larger society. To overcome this challenge, programmes of excellence where diverse groups are represented are important, both for the internal psychology and for the external psychology. Educational frameworks enabling people of all backgrounds to come together, community organizations and religious institutions all have a role to play as well. My attempt to get my friends to know each other was genuine, but didn’t work. I think that was due to the one-off nature of the experience. There wasn’t time for anything to flourish. I wanted to highlight that such efforts are necessary and must be sincere, but they also need to be consistent to achieve real, sustainable change.

**CPN:** We follow Wes through major turning points in his life such as when, after being released from prison, he endeavors to put his life on a more socially acceptable and crime-free track. Despite his hard work, he can’t earn enough to support his family, and remembers all the money to be made dealing crack. How do you convince people to not become involved in dealing drugs when law-abiding alternatives for earning a sufficient income are lacking?

**W.M.:** We need a two-pronged approach: one has to be external, in terms of preparing people who are incarcerated for re-entry, and preparing society for their re-entry. I think that the lack of preparedness and neglect on the part of elected officials can help explain why we have such a high recidivism rate of 70%. On the other hand, we also have to help individuals understand that second chances do become last chances, and that they have to take a more vested interest in their own long-term success—that means thinking long and hard about the decisions you’re making and the consequences of those decisions. Wes is the first one who would tell you, “Going back to dealing was the worst decision I ever made because I had no idea how close I was to being done with that.” It would have taken more time and more hard work, but today he would be with his family, he would have been there when his first grandchild was born, or when his daughter graduated high school and started college. He’s missing all of these things because he said to himself, “I’m done fighting.” We have to do a better job at helping people keep on fighting because as hard as it is, what’s even harder is to have to watch your family grow and develop and not be able to participate in that process.

# What Moves You?

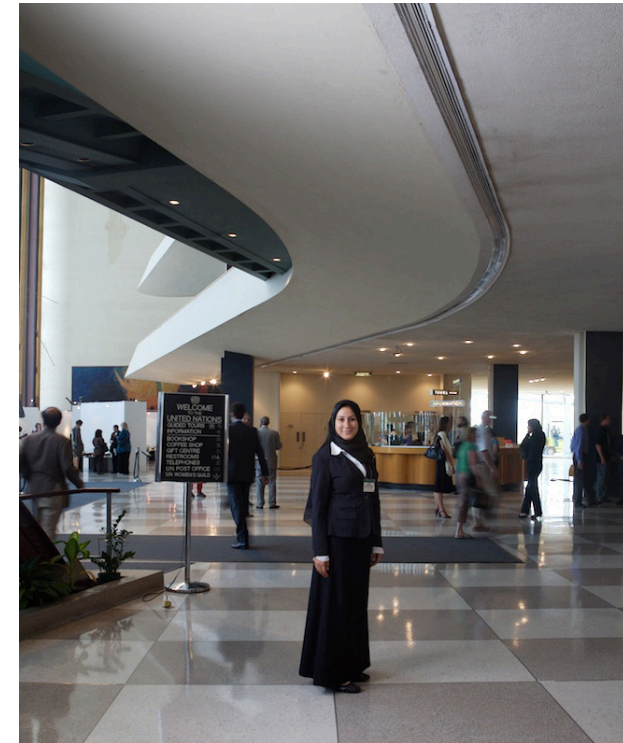

**Shafaq Khan**  
NGO Representative, IRSHAD, Jordan

**Children need to learn how to care for mother earth, rather than how to resolve the political conflicts.**

Growing up in an area where there was war because of land and oil, and where water was provided only once a week, taught me to realize how precious resources are. The next generation needs to remember the things that really matter, which is taking care of one another and taking care of the land they live on. IRSHAD is a center that provides psychological services and educational consulting in Jordan and throughout the region. I want to educate mothers, because they’re the ones who decide what products to buy and who ultimately shape the children.

We tend to focus a lot on the political conflicts in the region, but we really need to start focusing on the environment. Unfortunately, many people in Jordan are not educated about climate change and the limitations of natural resources. The environment does not have any borders, so this is an issue where different people from the region can come together. I feel that once people have a bigger cause to fight for, they won’t need to fight with one another, so let’s have that cause be mother earth. People who are not afraid to dream truly inspire me.

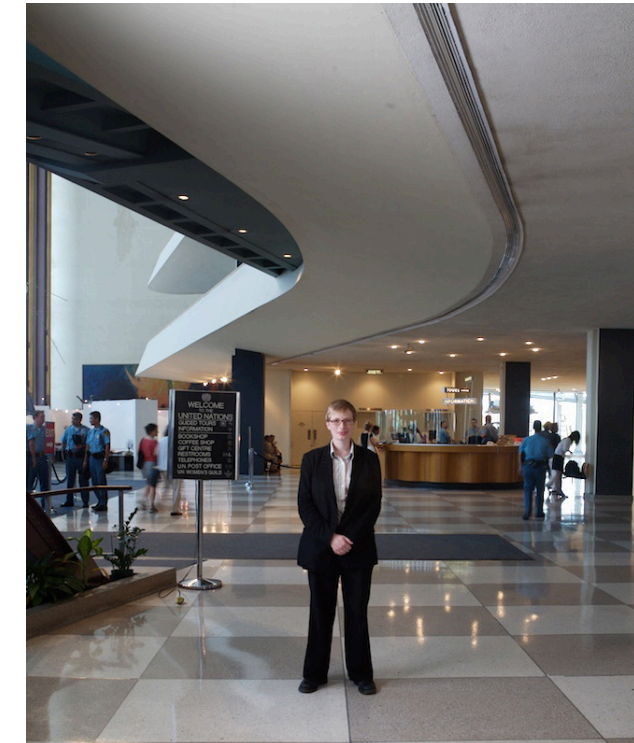

**Fiona Harvey**  
Environment Correspondent, Financial Times

**Once it becomes an economic and a regulatory issue, businesses really have to sit up and take a very keen interest in what’s going on.**

The whole business of how we run the planet, how we exploit natural resources, how we make sure we do it in a way that doesn’t destroy the very thing that gives us life, is very important. Politicians have to be elected and so they have to respond to the people that elect them. If people are interested in these issues, and if they let the politicians know, then inevitably there will be a political response. In some instances, governments do take the lead. In Europe, for example, the environmental concern of business is due to the regulations and carbon trading schemes that governments have imposed.

I became an environment correspondent because it has become a major issue, where a lot of things intersect, including politics, business, social concerns, science, and people. It touches everyone’s life. A few years ago, it would have been very difficult to get so many environmental stories into a newspaper like the Financial Times, but now, thanks to science, people are aware of the problems of climate change, water, pollution, and over-exploitation of natural habitats. We get a lot of feedback from readers, saying ‘yes, we want to know more about this’.

When people attend a conference, they don’t only want to listen and learn, they also want to express themselves and be heard.

What Moves You? on-site interview and photography sessions provide a platform for diverse conference participants to share their views. Their portraits and messages live on through traveling exhibitions and publications, as well as in other conferences, workshops and classrooms, where we present and facilitate dialogues on issues of social concern.

Featured here are excerpts from the series we conducted at the 60<sup>th</sup> Annual Conference of Non-Governmental Organizations associated to the United Nations Department of Public Information, “Climate Change: How It Impacts Us All.” Photos by Gala Narezo; Interviews by Shamina de Gonzaga.

About What Moves You?

Co-founded by Shamina de Gonzaga and Gala Narezo as a vehicle to discover the truthful, often inspiring stories that underlie the challenges facing our world. What Moves You? applies a holistic approach to research and documentary, with a view to investigating the complexity and relevance of an issue through the lens of people’s direct experiences.





# A DAY IN THE WORLD

**New York City, USA, 15:55.**

*Big city commuters have their unwritten codes of behaviour, most of which seem to involve disconnection from their neighbours. More than five million people every day ride the subway in New York. On this mid-afternoon train on Line 7, which connects Queens with Manhattan, there are meditators, text messengers, and window-gazers. One of the best-known sights on this line is 5 Pointz, a former warehouse that is now divided into artist studios and is decorated outside with famous and novice graffiti art.*

*Photo by Q. Sakamaki*

[www.aday.org](http://www.aday.org)  
© Max Ström





## The Spirit of Endurance with *Oliya Clarkson*

*Should geography and financial resources determine one's aspirations? How can one stay positive and creative despite the most unexpected of setbacks? In 2011, CENTERPOINT NOW (CPN) featured an interview with Olympian gold medalist bobsledder from Jamaica, Devon Harris, whose stunning success representing a Caribbean island nation in a winter sport inspired Hollywood and continues to motivate youth to explore their untapped potential. In this edition, we look to Oliya Clarkson, a young athlete whose arduous work to make Grenadian figure skating at the Olympic level a reality is matched only by her determination to continue reaching new heights, no matter what challenge she faces.*

The Caribbean country of Grenada, with under 110,000 inhabitants, has already left its mark on the world. Eminent individuals of Grenadian heritage include the legendary Malcolm X. More recently, in the athletic realm, 2012 Olympic-gold medalist in the men's 400-meter race, Kirani James, brought Grenada to the

center stage. Could Grenada also become internationally competitive in the prized winter sport of figure skating?

Born to a Russian mother and proud Grenadian father, Oliya Clarkson caught the eye and ear of Grenadian society when she began to pursue her dream of becoming an Olympic figure skater. A model, as well as an athlete, she has been described as an "exotic bird" on the ice. Having demonstrated remarkable talent representing Grenada, as well as her Russian roots, while both competing and serving as interpreter for the esteemed Russian coach of the 2013 International Skating Union's (ISU) World Development Trophy Championship in the Philippines, Oliya attributes her mission to her heritage: "Everything happens for a reason," she told CPN. "I learned how to speak Russian from my grandfather; we used to play chess together in the park! And I was introduced to figure skating by my mother, who loves skating, but never imagined I would do it professionally.

Most people don't associate figure skating with Grenada, or with any other country in the Caribbean. I don't think my Grenadian family even knew what figure skating was... They never came to my competitions, but eventually, when I would show them videos of me skating, they really liked them, which encouraged me to continue to pursue my dream of skating in the Olympics. When you go to Grenada, it's like a cleansing; the people are so warm and positive. I want to help put Grenada on the map."

The Honorable Derek James, Consulate General of Grenada, agrees: "She is a star in the making, future Olympian, and great inspiration for Grenadian youth. Oliya brings something new and unknown to Grenada and can familiarize the rest of the world with the beautiful island of Grenada."

CPN wondered how a teenager who has dedicated much of her young life to perfecting a sport copes with the uncertainty surrounding her aspirations. Oliya responded: "I feel very lucky to be able to go to school and also train. Everyone has their great day and their day that just doesn't work out. When you're off your game, it hurts. It's a bumpy road, but you work your way through it. You can have an amazing week of nailing everything and then three painful days where everything goes wrong. You don't know why, and you feel like a failure. It's difficult to handle, but it makes you stronger. Everyone's support system is different. I tell myself it will get better and talk to my friends and family, and listen to music. You can always go farther: For example, sometimes I think I've mastered a routine, but then realize I could lift my leg a little higher, or smile one more time. There's always something that can be improved."

Olympian Kirani James recognizes Oliya's potential: "I know Oliya well. Her hard work and dedication to the sport and Grenada are highly admirable, and I salute her trailblazing initiative." Invited to speak on prime time Grenadian radio, Oliya's story caught the ear of a prominent developer who wants to support the building of a functional ice rink to further the sport of figure skating in Grenada. As Grenada is already a sought-after location providing inexpensive or free parking for yachts, he envisions people transitioning from the sun-drenched decks of their yachts to a solar-energy powered ice rink, decorated on the outside by local Grenadian artists.

Despite the enthusiasm, challenges remain, as the expenses are significant. Oliya is aware of the material concerns: "More and more people are experiencing economic difficulties and it's true that a lot of money is required for figure skating and for the Olympics, in general. They have become very commercial, maybe because people have expectations of spectacular events. The positive side is that it makes the Olympics interesting for much larger audiences around the world, beyond the athletic community. Athletes can also be great role models and help raise awareness about issues."

Asked what issue she is passionate about, Oliya was unequivocal: "We have to do something about the environment and global warming. When the tsunami happened, I was in Japan. It scared me and I understood that there are simple things that everyone can do to help. An athlete who is going green can help everyone else. I try to inspire my peers about those things. My generation is very 'into' gadgets. I hope we can start moving away from that and spend more time in nature and with each other. I'm confident that we'll realize what's happening to the world, and we'll change it. Everyone deserves happiness."

At the age of 16, Oliya's resolve has already been put to the test. Six months after moving away from her family, to Michigan, to train with world-famous coach, Igor Sphiliband, and making great progress in her athletic practice, Oliya sustained a head injury while practicing an aerial lift with her ice-dancing partner. The blow was such that after weeks of unrelenting pain she was forced to discontinue the activity that had been part and parcel of her life since childhood and, for the time being, abandon the trajectory to which she had dedicated herself so completely: "The doctor said I couldn't skate, so there was no point in staying in Michigan. It was devastating. I felt very upset because my partner and I could have created something amazing, and because of the accident it's on a huge pause. I've been skating all my life with little time off. Whenever I would have a week of vacation, I wouldn't know what to do with myself. So, following the head injury, one of the hardest things was sitting in my room by myself, realizing I couldn't skate for now and not knowing what I would do. I started going on long walks. It's hard to adjust. At the beginning of September, I was supposed to go to New Mexico and then to the Czech Republic for the Grand Prix. It proves that you can't plan anything because you never know what will happen the next second. I don't know if anything can replace skating. Skating has been my life, but school is filling the absence I am experiencing right now."

True to her philosophy, Oliya is proving to be a trooper. Having already finished high school, Oliya was admitted to the New School's Eugene Lang College, where she has begun studying art history: "I love photography and modern art, and can see myself opening galleries one day. Everything happens for a reason. I don't know what the reason is for my injury yet, but maybe it will lead me to explore another passion. I've learned to never take anything for granted and live life to the fullest."

*Photo courtesy of Ms. Clarkson*



# Youth Making a Difference Past, Present and Future

by Cliff Frazier, Executive Director  
New York Metropolitan Martin Luther King, Jr. Center for Nonviolence (NYMLK)  
and Jason Higgins, NYMLK Director of Program Development

The New York Metropolitan Martin Luther King, Jr. Center for Nonviolence (NYMLK) is well aware of the role youth have played as a sustaining force in the past and the present in addressing the problems of racism, sexism and other societal aberrations.

In the early days of the Civil Rights Movement, in Birmingham, Alabama, hundreds of youth, ages 8 to 17, marched to protest the racism that had been imposed on the Black community. The youth were arrested and put in jail. The next day hundreds stayed out of school and marched in solidarity. By mid-week over 700 youth were put in jail. Eventually over 2,500 were arrested. All the jails in the city and county were filled. The police had used dogs to bite at the youth and fire hoses with 100 lbs of pressure per square inch, which knocked them to the ground and had enough force to tear the bark off the trees. These shocking images were shown on television stations throughout the world. The images infuriated millions of people. The children's act of courage and determination became major factors in garnering opposition to the racism that existed throughout the South. President John F. Kennedy called Civil Rights a moral issue and asked Congress to write a new Civil Rights Bill. Shortly afterwards he was assassinated. The Civil Rights Act was eventually signed by President Lyndon B. Johnson and enacted on July 2, 1964, benefitting minorities, women, the elderly, the poor, and many others.

The sustaining acts of courage, nonviolence and determination of youth and young adults were later captured in the Youth Leadership and Nonviolence training of NYMLK. Many of the students who participated in the youth leadership initiative have continued to dedicate themselves to making a difference as attorneys, doctors, teachers, technicians, community leaders and positive influences on young people. NYMLK is now expanding to include an international platform of youth to address the surging epidemic of violence, connecting with youth in Asia, Europe, Africa and America. In collaboration with the International Youth Leadership Institute, Jason Higgins, NYMLK Director of Program Development, will be working with

students in Dakar, Senegal, to create nonviolent social change in the area of renewable energy sources. They will learn about global warming, pollution, rising sea levels, deforestation and land degradation. In Gernsbach, Germany, he will be conducting Kingian Leadership workshops with youth from HLA Gernsbach High School and young professionals from the Daimler Auto Group.

In March 2011, United Nations Secretary-General, Mr. Ban Ki-moon, said that the "most impressive and moving experience of engaging people was with young people who are really the initiators of driving change." This was profoundly evidenced on March 25, 2013 when Youth Representatives of Non-Governmental Organizations associated to the United Nations Department of Public Information organized a groundbreaking youth briefing titled, "Raising and Empowering Youth to Break the Cycle of Violence against Women and Children." This collaborative initiative was a significant success, with 320 youth representatives from 48 countries, representing over 200 NGOs. Ademola Olugebefola, NYMLK's Main Representative to the UN, also serves on the NGO/DPI Executive Committee.

Youth leadership continues to be promoted by PeaceJam, an educational initiative built around 13 Nobel Peace Laureates who work with youth to pass on the spirit, skills and wisdom they embody. The mission of PeaceJam is to create young leaders committed to positive change in themselves, their communities and the world. Members of the PeaceJam Foundation include The Dalai Lama, Betty Williams, Rigoberta Menchú Tum, President Oscar Arias, Archbishop Desmond Tutu, Aung San Suu Kyi, Máiread Corrigan Maguire, Adolfo Pérez Esquivel, José Ramos-Horta, Jody Williams, Sir Joseph Rotblat, Shirin Ebadi and Leymah Gbowee. PeaceJam and its award-winning programs have been nominated for the Nobel Peace Prize seven times during its 17-year history. The International Communications Association (ICA) and Lend Yourself to Life (LYTL) are partnering with the PeaceJam Foundation to bring PeaceJam to New York, to serve the Mid-Atlantic region.

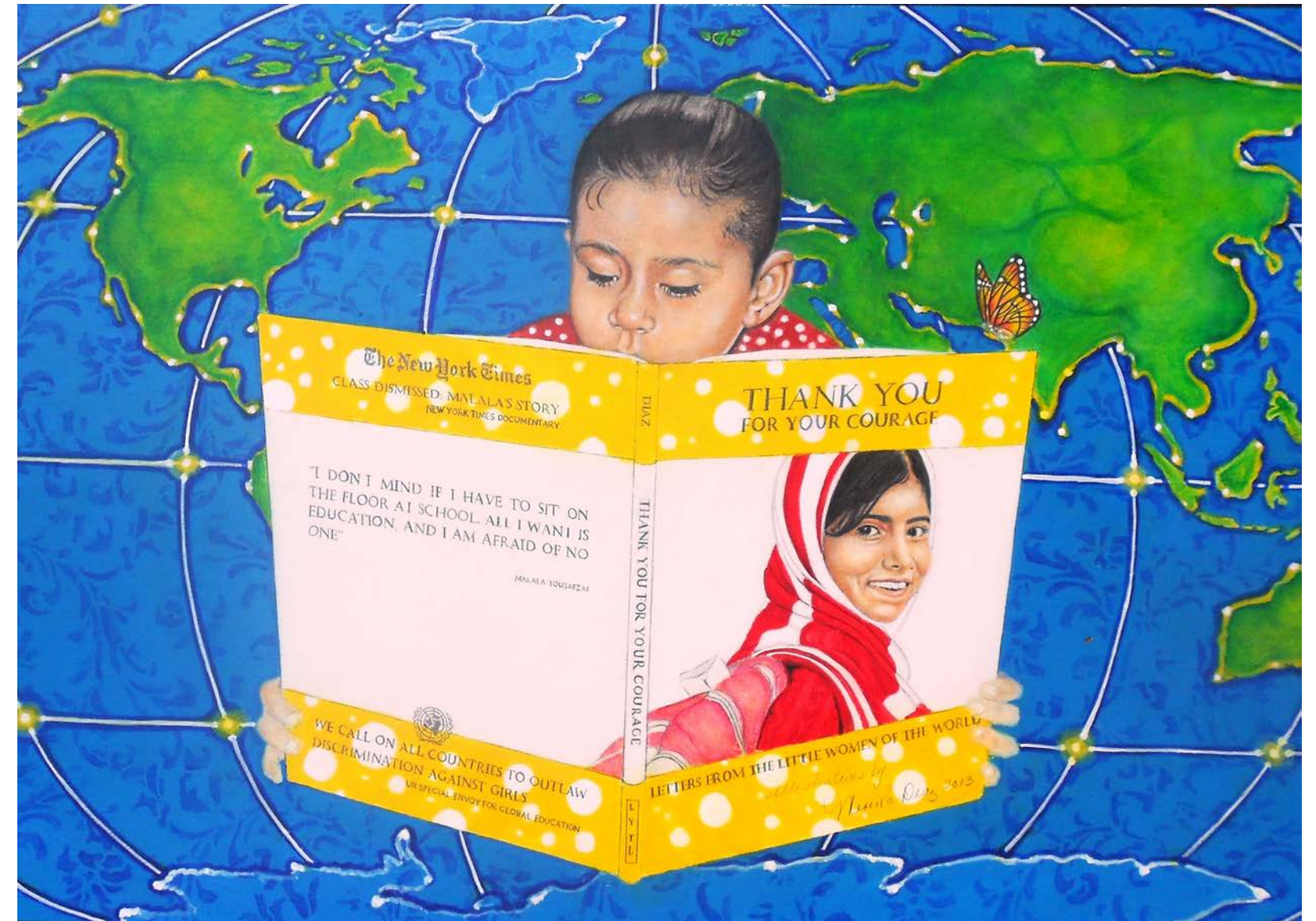

Among young people of outstanding courage, we have to recognize Malala Yousafzai, a 15-year-old Pakistani girl, who stood up for the rights of women and girls to obtain an education, have freedom and self-determination. On October 9, 2012, she was on a school bus and was shot in the head by a lone gunman. She survived this attack and is back in school. She has refused to be discouraged in pursuing the realization of her dream and continues to speak up for the rights of girls and women. She was the youngest person to be nominated for the Nobel Peace Prize and was nominated for the International Children's Peace Prize. She is the winner of Pakistan's First National Peace Prize, and Time Magazine featured her among "the 100 Most Influential People in the World."

The common thread in these activities is young people being involved and making a difference. Too often nations of the world ignore the potential of youth. They are untapped and underutilized. The belief is that they have no experience and little to offer. This is unfortunate. They are a treasure and need to be nurtured. NYMLK's commitment is to help support and sustain their potential and value in making a difference.

Art on this page:  
Malala: Thank you for your courage, by Minerva Diaz,  
Acrylic and pencil on canvas.  
Text on front book cover Top section: Thank you for your courage.  
Bottom section:  
Letters From the Little Women of the World  
Illustrations by Minerva Diaz.  
Text on back cover; New York Times - Class Dismissed:  
Malala's Story - New York Times Documentary.  
Middle section:  
"I don't mind if I have to sit on the floor at school. All I want is  
education, and I am afraid of no one" Malala Yousafzai.  
Bottom section:  
"We call on all countries to outlaw discrimination against all  
girls" UN Special Envoy for Global Education.





# A DAY IN THE WORLD

**Laem Mae Phim,  
Thailand, 14:43.**

*Bhumpen has been a monk for 11 years at a temple north of the beach resort of Laem Mae Phim. Every day he treats villagers with back or joint problems. They talk about personal issues and get a half-hour's treatment on his vinyl mat. The 20-baht fee goes to the temple. Many of the monks are soccer fans—43-year-old Bhumpen's team is "Manjo" (Manchester United).  
Photo by Björn Larsson Ask.*

[www.aday.org](http://www.aday.org)  
© Max Ström



# Healing through Music and the Power of Thought

with Mr. Kong Tai



**“The more man meditates upon good thoughts the better will be his world and the world at large.” - Confucius**

Of the Four Books that constitute the pillars of Confucianism—*The Great Learning; The Doctrine of the Mean; The Confucian Analects and The Works of Mencius; and The Six Classics* (The Book of Music, The Book of History, The Book of Changes, The Book of Rites, and The Spring and Autumn Annals)—the latter has been incomplete. According to investigations by scholars, “The Book of Music,” which was originally part of *The Six Classics*, was lost when the first emperor of the Qin Dynasty ordered that the books be burned and buried.

Mr. Kong Tai, who achieved great acclaim in China at a young age, with demonstrations that broke the Guinness World Book of Records in twisting steel spoons with one bare hand, went on to create a unique style of calligraphy using a steel spoon—“Spoon Calligraphy.” As his artwork became sought-after by collectors in China and abroad, Mr. Kong Tai expanded his interests and studies, dedicating himself to resurrecting the forgotten teachings of the “Book of Music.” Reflecting on the premise that music is key to bringing harmony to life itself and is therefore an integral component of inner happiness, he explains: “Ancient Chinese culture considered that organization and harmony were the ultimate goals of human society, and that these goals could be attained through formality, or structure, and music. Harmony, resonance, and symbiosis are the characteristics of music, as well as the most essential expressions of positive energy. Rather than seek external excitement and passion to obtain the feelings of happiness and joy, internal joy and positive energy can be tapped in one’s own consciousness. By understanding that music is energy, it is possible for people to heal themselves.”

He went on to establish the Chinese Music Cultural System and formed a music-based healing methodology, the benefits of which have been experienced by countless audiences for over two decades, since holding his first “Wellness Music Concert” in the Beijing Zhong Shan Park concert hall in 1990. Committed to sharing his skills and insights with an ever-more diverse public internationally, the Kong Tai Power of Thought International Study Center is being launched in New York City, with the collaboration of Ms. Dan Qing Chen and Amy Su Zhang, so as to further engage in community outreach and intergenerational dialogue and support.

Having been awarded the title of “Charity Ambassador” by the Chinese Charity Association for his philanthropic efforts, Mr. Kong-Tai’s cultural innovations have incorporated cartoons, movies and other media to introduce his philosophy in accessible forms. Asserting that, “the seeds will determine the fruit; and the thought will determine the consequence,” through Mr. Kong Tai’s course, “The Power of Thought and the Energy of Music,” participants learn that thoughts generate personal energy and consequently shape the outer manifestations of life. Attuned to nature, he further advocates learning from animals, bees, in particular, as their model of working together can be applied to human societies for the betterment of our world.



Calligraphy on top: “Happiness and Longevity” by Mr. Kong Tai using a spoon as a medium of application. Photo, right: Mr. Kong Tai.

# Meditation and Sustainability

by David Lynch



Stress is “the black plague of the twenty-first century”—a pervasive and insidious epidemic that defies conventional medical approaches for either prevention or cure. It undermines health, fueling spiraling health costs everywhere, severs fragile family and community bonds and is a cause of substance abuse, crime and violent behavior.

Isn’t it ironic, then, that the most effective, cost-efficient approach to addressing the epidemic of stress among individuals and societies may come not from a new wonder drug but from a practice as old as mankind: meditation.

In the past forty years, due in large part to a burgeoning body of medical research, meditation has emerged from the shroud of myth and mysticism to become a widely used and prescribed antidote to stress. I started the David Lynch Foundation for Consciousness-Based Education and World Peace eight years ago to provide meditation instruction to at-risk populations worldwide. I chose one particular technique, Transcendental Meditation, because it is considered the “gold standard” of meditation practices. Since our establishment in 2005, nearly 500,000 underserved youth, women who are survivors of sex trafficking, and veterans suffering from PTSD have learned to meditate.

What have we learned? Three things:

First, that if children live in stressed, violent communities there is little chance they will come out undamaged. In fact, in such an atmosphere of tension, health, educational and vocational training programs struggle to take hold.

Second, properly understood and practiced nonreligious meditation really works. Hundreds of studies, many funded with tens of millions of dollars in grants from the National Institutes of Health, have shown that Transcendental Meditation (TM), in particular, reduces stress and stress-related disorders, including hypertension and risk of stroke by nearly 50%, symptoms of post-traumatic stress among meditating veterans by 50%, and dropout rates among meditating students in crime-ridden neighborhoods by 86%.

And third, when entire families, schools, businesses, and military bases meditate there is a complete transformation in the health, productivity, performance, and quality of life of the family, organization or institution as a whole.

Meditation, then, in my mind, is the key to sustainable development because it reduces, and helps to eliminate stress—the major obstacle to health and learning.

But research shows it can do much more. It can boost creativity and resiliency. Electroencephalographic (EEG) and brain scans show TM actually optimizes brain functioning, strengthening the neural connections between all parts of the brain, including the all-important frontal lobes (which govern executive functioning). And from research we know that everything good about the brain depends upon its integrated functioning. No wonder then that meditating high school students score higher on standardized academic exams, meditating college students score higher on IQ tests, and meditating business leaders report improved creativity, decision-making, and problem-solving ability.

With our success over the past eight years, my Foundation is now poised for a bolder, more global outreach. Countless millions of children—many now warehoused in refugee camps in Jordan or holed up in shantytowns in Brazil—are witnesses to tragedy and horror in ways that few of us even comprehend. Yes, they must certainly have clean water and healthy food and proper shelter, medical support and education. But a plan for sustainable development must also include profound relief from the death grip of post-traumatic stress disorder. The David Lynch Foundation is working with NGOs and other international health, educational and peacekeeping organizations to provide meditation instruction to any and all children and teens (and adults) who want to learn.

In my mind sustainability requires freedom from poverty, from illiteracy, from disease, from trauma and stress. In my mind, sustainability requires Transcendental Meditation.



Photos courtesy of the David Lynch Foundation.

David Lynch, founder and chairman of the Board of Trustees of the David Lynch Foundation for Consciousness-Based Education and World Peace, is an award-winning director, writer and producer. His work includes *Eraserhead*, *Elephant Man*, *Wild at Heart*, *Twin Peaks*, *Blue Velvet*, *Lost Highway*, *Straight Story*, *Mulholland Drive* and *INLAND EMPIRE*.

[www.davidlynchfoundation.org](http://www.davidlynchfoundation.org)





# Rory's Legacy:

## *Combatting Sepsis and Saving Lives Through Education and Awareness*

by Kathy Thompson

In our lives we are touched by special people who leave a mark and a memory that will never be forgotten. Such a person was Rory Staunton, a beautiful boy who left this earth too soon.

It's every parent's worst nightmare: the death of a child. And that nightmare is compounded with the knowledge that the death was preventable. This is the story of 12-year-old Rory Staunton, but it is also the story of so many others.

Though he was only 12 when he left us, Rory had achieved so much and inspired so many people, a fact that became evident during the massive outpouring of grief after his untimely death. At his New York memorial, over 1,400 people gathered to hear about the legacy of a young boy who meant so much to so many, and whose passing inspired us never to forget him, and also to ensure that no other families will face the profound grief his family suffered. Among those that offered their sympathies, were President Barack Obama, President Bill Clinton and Secretary of State Hillary Clinton, and Irish President, Michael D. Higgins.

Rory always looked out for others. He led a campaign in his school to stop the use of the word 'retarded,' even working with the Special Olympics of New York to embrace change and foster social responsibility by eradicating the use of that word in everyday language.

He set up the award-winning Lego Robotics Team, founded and captained the Daniel Webster Debate Team, and served on the Student Council at his school, and was a proud member of Project Green, a group dedicated to creating a more environmentally friendly world.

Rory had already flown a plane, following his hero Capt. Sully Sullenberger, written the North Korean dictator asking why his people were so mistreated and even met President Obama. His idols were Rosa Parks, Martin Luther King, Jr. and JFK.

All in all, Rory was set to achieve great things.

Rory died from a preventable disease that if recognized early enough would have been treated successfully. He received a cut from a fall in the gym at his school. A deadly toxin entered his body as a result. Early recognition of sepsis would have saved him. Unfortunately that did not happen for Rory, but this gentle boy would want more than anything to ensure that no other child or family would go through what he and his loving parents, Ciaran and Orlaith, his sister Kathleen, and their extended family suffered.

Sepsis is common and often deadly. It is a progressive shutdown of the body's organs and systems following an infection that enters the blood or soft tissue. It remains the primary cause of death from infection, despite advances in modern medicine. Often misunderstood as 'blood poisoning,' sepsis today is one of the leading causes of death around the world.



Sepsis affects over 26 million people worldwide each year. Of those affected, one third die. It is the leading cause of death in hospitals and kills more people annually than AIDS, prostate cancer, and breast cancer combined. In the developing world, sepsis accounts for 60-80% of lost lives in childhood. It is the largest killer of children and newborn infants in the world. Those who survive often experience life-altering consequences with missing limbs or organ dysfunction.

The cost of sepsis is high and rising. In the US today sepsis medical costs account for an estimated \$17 billion annually in national healthcare expenses. The costs related to long-term

damage resulting from sepsis are unknown. And the human cost of sepsis is incalculable.

Experts agree that the key to fighting sepsis is ensuring quick diagnosis and treatment within the "golden hour" when it can be most effective. Pilot initiatives in some hospital systems have shown great strides in decreasing sepsis mortality through effective implementation of what is basically a "checklist:" a standardized protocol to facilitate quick and accurate diagnosis and fast and effective treatment as soon as any sign of sepsis arises.

In an effort to raise awareness and educate people on the dangers of sepsis, Rory's parents created The Rory Staunton Foundation, which is dedicated to three core principles:

1. Raising awareness of sepsis risks for children and young adults through education and outreach programs supported by The Rory Staunton Foundation
2. Improving pediatric sepsis diagnosis and rapid treatment protocols for hospitals and medical clinics
3. Training teachers and staff in public and private schools to recognize and arrange for prompt treatment of students potentially exposed to bacteria, including prompt notification to parents.

Through the efforts of The Rory Staunton Foundation, on January 29, 2013, Governor Andrew M. Cuomo announced that New York State will lead the nation by becoming the first state to require all hospitals to adopt best practices for the early identification and treatment of sepsis. These regulations are rightly named Rory's Regulations.

"By adopting the regulations proposed today, New York will lead the nation and establish a gold standard for patient care that other states should follow," Governor Cuomo said. "I extend my most sincere appreciation to the Staunton family for their strength and unwavering commitment to this vital effort."

As a result of the remarkable success of the efforts of The Rory Staunton Foundation, Global Sepsis Alliance (GSA), a non-profit organization supporting the efforts of over 1 million caregivers in more than 70 countries, announced in April 2013 that they will unite with The Rory Staunton Foundation to fight against sepsis and further expand the GSA's World Sepsis Days worldwide.

Rory's father Ciaran reflects: "For anyone that has carried their son's or daughter's coffin, it's unnatural. A child who loses a parent becomes an orphan. If a man and wife lose each other, they become widow or widower. It's so unnatural; there isn't even a word for families who lose a child. Our family has been handed a life sentence."

Every 15 seconds, every third heartbeat, someone dies of sepsis. Let us all work as a global community to eradicate this threat in our lifetimes, and with that success we'll honor that 'beautiful boy who left this earth' much too soon.



# Is There A Doctor On Board?

by Kóan Jeff Baysa, M.D.

Call me a mis-matchmaker of ideas, for I specialise in designing and producing projects and events that mash-up seemingly disparate subjects. I like the Russian-derived term, ostranenie, that means defamiliarization, to see in strangeness, to ultimately acknowledge one's complicity in making known what is known. And with defamiliarization come both the slowing down and the increased difficulty (impeding) of the process of reading and comprehending and an awareness of the artistic procedures (devices) causing them. (Margolin 2005) It is part of the practice of contextualization, and what effective curators perform: making the familiar strange. But I'm getting ahead of myself. Let me back up and tell you a story.

I was praying that it was going to be a smooth landing for I wasn't wearing a seat belt. And neither was the old Asian gentleman I was kneeling next to on the floor of the airplane's galley. The inbound flight was about 80 minutes from landing at SFO, and we were prioritized for an emergency landing with a medical team ready on the ground. Apparently traveling alone, the elderly Asian gentleman who did not speak any English suffered a cardiac arrest in his seat. The announcement came over the PA, "Is there a doctor on board?" In my traveling garb, sporting a hoodie, torn denims, and shoes without socks, I must have looked like an unlikely candidate as I responded along with two other doctors and a nurse. There was no crash cart on board. The patient was placed supine in the aisle, and we took turns performing CPR. After more than several cycles, he was resuscitated. After he appeared to be stable, in case he arrested again and to clear the aisle, he was transported to the galley for observation. I volunteered to remain with him during landing while the others went back to their seats, and held his hand reassuringly, although I was tense with the prospect of beginning CPR again. I held my breath as the plane touched down on the tarmac and came to a shuddering stop. Fortunately, the bewildered and scared patient remained stable until the medics boarded and his care was transferred to them.

Approximately 48 hours prior to this midair emergency, I was opening *d'Asie d'Afrique*, the art exhibition that I initially curated in Manhattan and was now traveling to Hong Kong. The concept was based on my rumination of how Africa and Asia did not often occupy the same mental space. Research revealed China's well-documented pursuit of African oil, but how about aesthetics? I searched for artists who accomplished this in their visual art, sourcing Japanese ganguro, American hip hop cultures, and scholarly studies on these phenomena. *ArtAsiaPacific* magazine singled out the exhibition as one of the best shows of the year. As a curator with a medical degree, I bring disparate topics together, like Africa and Asia, like art and science. Welcome to my world!

As sentient beings, we experience and acquire knowledge of the world through our senses, but it is ultimately the "perceiving" organized by the neural networks in the brain that constitute our "realities." Disrupting the long-held divide between the senses and the intellect, and between perception and meaning, both artists and scientists utilize varying methodologies, but find common ground in their investigations into the nature and structure of reality, driven by curiosity, experimentation, and a sense of wonder. In carving out and occupying this niche of creativity and medicine, I found that there is a reciprocal catalysing that fuses the aesthetic, image-based intuitive approach with the scientific, quantification-based deductive method.

I've been straddling the realms of art and science as far as I can remember, and my choosing medicine came from interests in marine biology and physical anthropology and the associated areas of marine pharmacology and paleo-forensics. I ended up completing my medical education with a fellowship at UCSF in allergy and clinical immunology, a specialty that attracted me because it was non-organ specific with a holistic approach,

factoring in lifestyle, diet, environment, psychology, and neuroscience. I became especially interested in what constitutes a disease in the context of specific cultures, and more recently on how the olfactory sense might be used to positively impact memory disorders. This investigation is based on three premises: that the brain is anatomically "wired" differently for this sense; that the loss of sense of smell is one of the first symptoms of Alzheimer's and Parkinson's diseases; that the brain is neuroplastic, dynamic and regenerative to certain degrees.

My interest in art tracked a parallel path to my medical career, and I collected art as a way of vicariously remaining involved in the world of museums and galleries while undergoing lengthy medical training. Amassing an art collection is essentially a curatorial endeavor, and what ensued was acceptance into the Whitney Museum Independent Study Program and subsequently into AICA, the International Association of Art Critics. An assistant clinical professor of pediatrics, I gradually shifted my consultative allergy practice from Honolulu to TriBeCa, and recently segued from an office-based practice to a nonclinical practice of independent research and health application development. Moving upstream in the healthcare process, I seek to help a greater number of individuals on the broader fronts of patient engagement and education in disease prevention and treatment.

Medicine remains integral to my cultural and curatorial practices, and I combine the two in projects at every opportunity. Recently, in conjunction with the 5Day Mission project in Los Angeles, I was part of the clinical team supported by UNRWA in Beirut, Lebanon, restoring sight to 60 afflicted individuals. While on site, we also worked with students from the refugee camps on mural projects at their school and with a local emerging artist who had a dream of a refugee camp wall beautification project. Following Lebanon, I went to Bosnia to help a friend establish an artist residency program in Tuzla, then also consulted with health department officials who sought advice on health strategies regarding elder care, autism spectrum disorders, and chronic asthma in their regional medical system.

Medicine informs a large part of my curatorial practice. *Divining Fragments* at the Center for Photography at Woodstock, and *Seeing Ourselves* at MCPI in Manhattan brought together the medical imaging works of artists and physicians. In the former show, it was shown digital images are only re-presentations and partial truths that empower us to recognize the political, social, and economic factors that affect the interpretation of these images. The deployment of medical imaging pictures by contemporary visual artists reflects the innovative and alternative perspectives that art often offers to science, while acknowledging that both art and science are investigated by social beings within social contexts.

In the latter exhibition, 62 artists were chosen for their representations of the brain and cognitive function. Recent imaging techniques have enabled us to actually visualise the granules in the hippocampus where memory is being formed, and where there may be clues to the origins of schizophrenia. Including displays of the state of the art MRI, PET, CAT images alongside art inspired by these medical imaging modalities, *Seeing Ourselves* was an art exhibition designed to make breakthroughs in biomedical imaging accessible to the public and to explore the commingled aesthetics of modern medical imaging and contemporary visual art. In diagnostic imaging, the

areas of visualization, medicine, and technology come together. Since human subjectivity and identity are linked to the changing perceptions of vision and visualization, we make and remake our visual experiences of the world within these different contexts. It is fascinating to imagine MRI and PET scans as the body's way of illuminating itself from within.

One of the show's intentions was to encourage the sharing of institutional knowledge as well as to examine the contexts of



Kóan Jeff "KJ" Baysa M.D. is the Advisory Board Chair for Collectrium; Chief Medical Officer, Medical Avatar; Emeritus Critic-in-Residence, Art Omi; and Chief Strategy Officer, Institute for Art and Olfaction.

senseight@gmail.com  
senseight.tumblr.com





these medical images from the perspectives of the humanities, in addition to the sciences. By displaying the most advanced medical imaging examples in conversation with other visual images, and as artwork themselves, ingrained distinctions between art and science were blurred and encouraged audiences outside of the medical communities to appreciate and to be inspired by the remarkable scientific advances.

The current project that pulls all of these wide interests together is “Medical Avatar,” a mobile patient app that gives each person his or her own 3-D anatomical “avatar” image for improved health management and connectivity to doctors and clinical services. With the eclipse of the long-held doctor position of high priest as a consequence of the shift to personalized medicine based on genomic research and the ubiquitous use of hand held devices, personalized interactive health and medical visualizations are the adhesive interface missing in most engagement strategies. Personal visualization opens up a world of self-image exploration with the benefits and consequences of changing one’s behavior for the positive.

Through the strategy of ostranenie as a medical curator and cultural worker, the overarching principles and concepts guiding my career trajectory have been to lead the engagement of individuals in the acknowledgement and appreciation of their own micro and macro environments through the senses, i.e., in its wonderment as well as its fragility and finitude. By liaising with different sectors in art and in science, I encourage the commingling of different perspectives, integrating the most relevant insights and engaging individuals with new health and lifestyle attitudes.

Artwork for this article:

1. Pablo Garcia Lopez  
Golden PET (2009), silkscreen and bowties on Plexiglas, 51" x 51"  
“My work explores the connections between neuroscience and art and I am especially interested in making associations between both disciplines to popularize the discoveries related to the functioning of the brain, trying to create a more humanistic culture.”
2. Iona Rozeal Brown  
a3 blackface #50 (2003), acrylic on paper, 30 x 22 in.  
[www.tumblr.com/tagged/iona-rozeal-brown](http://www.tumblr.com/tagged/iona-rozeal-brown)
3. Elizabeth Jameson  
Celebration, anglogram of the brain, solarplate etching on paper, 5" x 5"  
“My fascination with medical imaging and brain scans has a personal basis. Diagnosed with the disease of multiple sclerosis, I found myself confronting stark images of my brain that seemed equally frightening and mesmerizing. In tackling this contradiction, I felt a strong urge to reinterpret these images—to use them to explore the amazing biological structure of the brain. My current artwork saturates these cold, two-dimensional computerized pixels with rich colors that transform scientific images into portraits of individuals with all the frailties, humor, and idiosyncrasies that make us human.”  
[www.jamesonfineart.com](http://www.jamesonfineart.com)

# The Evolution of the Social Brain

by Allan Young

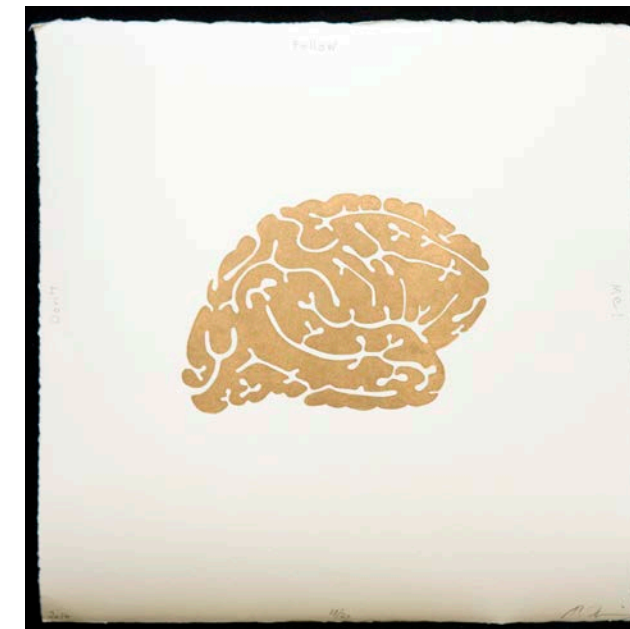

Mathematical models indicate that these evolutionary mechanisms alone would have been insufficient. It is clear that the stability and development of prehistoric human societies would have depended on the emergence of an innate tendency to punish non-reciprocators (“cheaters”). But this solution embodies its own evolutionary contradiction. Enforcing norms consumes resources, and the targets of punishment may react violently. Therefore the costs of being an enforcer of norms are likely to exceed the benefits. For this reason, the enforcer’s behavior is referred to as “altruistic punishment.” Experimental evidence suggests that the social brain evolved a neurochemical solution to this dilemma: enforcers would be motivated through secretions (notably dopamine) associated with pleasure, rather than through material rewards. What may have happened next is described by David Lord Smail in his recent book *On Deep History and the Brain*.

A hierarchical social order emerged in the course of human evolution. The social elite maintained dominance by controlling bodies (the dominated classes) directly through coercion and indirectly by regulating their neurochemistry. High levels of stress would be created and sustained through unrelenting and unpredictable terror and repression. At the same time, the dominated masses would be periodically treated to sadistic spectacles arranged by the elites. These spectacles would deliver a double dose of pleasure: the pleasure of anticipating and gawking at suffering and the pleasure of transient relief from the onlookers’ everyday stress. Thus the ruling classes of early civilizations created and manipulated environments of suffering and pleasure to their own advantage.

In the 17<sup>th</sup> and 18<sup>th</sup> centuries, things began to change, at least in Western Europe. Alcohol, opiates, sugar, caffeine, tobacco, pornography and sentimental novels were widely available: “autotropic” mechanisms mimicking or altering the effects of dopamine, serotonin, norepinephrine, and other chemical messengers. Gin, chocolate, and novels displaced empathic cruelty for the relief of stress; empowerment existed to take control of the brain’s reward matrix. Autocracy gave way to constitutional governments; regimes based on random acts of terror declined. Now, the 21<sup>st</sup> century has become a world of consumers and, for privileged segments of global society, an “autotropic” way of life.

Recent developments in neuroscience research signal the discovery of a “new unconscious.” The new unconscious is located in the human brain—to be more precise, the social brain. This term “social brain” reflects a new perspective on the brain, acknowledging its ability to detect intentions and feelings in other brains. This ability enables us (or rather our brains) to predict, manipulate, and otherwise respond to other people’s behavior. The social brain is the product of seven million years of human evolution.

The first stage of this evolutionary process coincided with the emergence of altruism, a behavioral tendency that is shared with other mammalian populations. Evolutionary biologists define altruism as an act in which an individual sacrifices some or all of his reproductive potential for someone else’s benefit. Altruism is a puzzle in genetically heterogeneous populations, since it will disadvantage the altruist’s group if it is not reciprocated. Individuals who lack this innate tendency, and thus do not automatically reciprocate, have an advantage: they enjoy the benefits of altruistic sacrifices without paying the costs. In time, non-reciprocators would outbreed the innate reciprocators. Social relations and structures based on cooperation would collapse, and social evolution would terminate. In order for a progressive system to endure, there must be a mechanism promoting reciprocation. A partial solution was provided through the emergence of innate values and sentiments based on fairness and obligation.

*Art on this page: Bodo Korsig Don't follow me (2010), embossing/paper, 20 x 20 cm "Brainpower. For about ten years now my main theme has been the model of human behavior under extreme conditions such as fear, violence, pressure or death. In this I am especially intrigued by the artistic conflict of those human neurological and cognitive processes that it is difficult to record purely scientifically. I want to provoke a new perception of the processes at the interface of biological determination and human awareness. Through biological figure, metaphysical symbol, or the crystallization of the spoken word, I am interested in creating a new pictorial language as the expression of brain functions in human awareness." www.korsig.com Image provided by Kóan Jeff "KJ" Baysa.*

Allan Young is professor of anthropology at McGill University, in Montreal (Quebec), Canada.

[www.neurobureau.org](http://www.neurobureau.org)



# A Healthy Epigenetic Lifestyle à la Croatia

by Koraljka Gall Troselj, MD, PhD

Head, Laboratory of Epigenomics, Division of Molecular Medicine, Rudjer Boskovic Institute

Each cell in our body possesses an identical set of genes. Their microanatomy, as well as their subtle diversity, polymorphisms, are the focus of a scientific discipline called genomics. The structure of genes reflects the stability of the DNA molecule which is transmitted to daughter cells as part of every cellular division. Hence, genes possess relatively stable structures and some genes, conserved through evolution, show a very high degree of homology in their structure across different species.

Isn't it surprising then that cells with identical genetic material significantly differ in their shapes and functions? For example: brain cells, neurons, are significantly different than liver cells in the same living organism. The major reason for this phenomenon is related to the word "activity." Not all genes are active at the same time in all living cells belonging to one organism. Their activity is strictly regulated during specific time windows and in a given cell/tissue. For example, a well known tumor marker, CEA (carcinoembryonic antigen), is a protein coded by the gene CEACAM5. The activity of this gene is necessary during early fetal life and continues, thereafter, at very low activity levels, mainly in the epithelial cells of the gastrointestinal tract, cervix, and the prostate. This basic expression includes very sensitive and precise mechanisms to control CEACAM5 gene activity. The lack of, or disturbance in, these mechanisms, frequently present in cancer cells, leads to uncontrolled, increased CEACAM5 activity. This activity can be measured in the blood by measuring the level of CEA protein, which is also a target for vaccine-based immunotherapy.

The presence of a specific gene in a cell does not necessarily mean that the gene is active. The mechanisms, which regulate gene activity, resulting in its silence, or active state, are known as "epigenetic mechanisms." The term "epigenetic" was introduced in 1942 by the developmental biologist, Conrad Hal Waddington. Today, epigenetics is most commonly defined as "the study of reversible heritable changes in gene expression that are not due to alterations in DNA sequence." Understanding epigenetic changes as biological modulators of gene activity, inevitably leads to recognizing the possibility of controlling gene activity. Indeed, the 21<sup>st</sup> century is the era of aging populations in which cancer

is considered to be a chronic disease. Facing these facts, can we, through modulating our epigenome, influence the activity of our genes and create a gene-communication-network that will protect our cells from malignant transformations?

It has long been known that some types of food protect against cancer. A good example is the Mediterranean diet, with major attributes including: a high monounsaturated:saturated fat ratio, moderate ethanol consumption, high consumption of legumes, cereals, fruits and vegetables, low consumption of meat products, and moderate consumption of dairy products. Can prolonged intake of this type of food modulate our gene activity and protect us from certain types of cancer? The estimation is that up to 25% of the incidence of colorectal cancer, 15% of the incidence of breast cancer, and 10% of the incidence of prostate, pancreas, and endometrial cancer, could be prevented if the populations of highly-developed Western countries would shift to the traditional Mediterranean diet.

In order to appreciate the biochemical basis of food ingredients, which allow the activation of "protective" genes and the silencing of "bad" genes, one needs to understand chromatin flexibility. Chromatin, located in the cell's nucleus, is composed of DNA and histone proteins. The DNA molecule is wrapped around histone proteins. The degree of wrapping determines the accessibility of the DNA molecule to certain proteins, for example, to transcription factors, which are positive regulators of gene activity. If the binding of DNA to histone molecules is weak, then the semi-open structure of chromatin (euchromatin) makes the DNA accessible to transcription factors which bind to it. As a consequence, the genes in the area of euchromatin become active. If this structure becomes closed (heterochromatin), with DNA and histone tightly wrapped, the DNA will not be accessible and genes in this region will be silenced. For various reasons, such as in mutating, some genes may become "bad" (oncogenes), forcing the cell to divide in a manner that escapes the protective mechanisms influencing its survival and death. These are major contributing factors to cancer.

Ideally, these "bad" genes should stay hidden in the chromatin structure and be silenced.

While our understanding of cancer has improved with regard to its occurrence, development, and treatment, prevention is most important for 21<sup>st</sup> century medicine. Can we eat healthy and stay healthy with respect to cancer by following traditional diets? I will focus on well-known nutrients that are very popular in my homeland of Croatia, which, with its unpolluted nature, represents a top class reservoir of ecological, "anticancer foods" that call for exploration and enjoyment in full measure.

Chromatin shifting between the two basic states, depending on the need for a specific gene's activity, can be modulated by food. The underlying principle of chemoprevention depends on the activity of two types of genes: oncogenes and tumor suppressor genes. If extended ("euchromatin"- histone proteins acetylated), the genes in the area become active, which is exactly what we want to happen with tumor suppressor genes; if condensed ("heterochromatin"- histone proteins deacetylated), the genes become silent. Ideally, these are the mechanisms to be selectively applied to silencing oncogenes and activating tumor suppressor genes. Both forms of chromatin depend on different modulators.

Garlic has a very important place in the Mediterranean diet. Its major organosulphur compound, diallyl disulphide (DADS), has been shown to have an inhibitory effect on enzymes with histone deacetylase activity. As a consequence of this specific mechanism of action, histones remain acetylated and the form of euchromatin remains preserved in the regions of DNA where the tumor suppressing genes, hence protecting against cancer, are located.

However much admirers of Dalmatian cuisine resist when eating fresh fish, nothing can match the famous combination of garlic and olive oil applied to a variety of dishes. It is not surprising, then, that even at the level of histone protein modifications, the two act in a similar fashion. Some components of olive oil, like polyphenols secoioides, influence histone molecules by supporting their hyperacetylated status. This particular mode of action, prevention of histone deacetylation, represents a very strong focus in cancer therapy research.

There are seven classes of histone deacetylase inhibitors. Historically, these compounds were widely used in psychiatry. With new insights into cancer, including from the viewpoint of epigenetics, they have become very interesting for successful cancer therapy. The point is that some kinds of food have exactly the same mode of action as various synthetic drugs. But, what is frequently forgotten, is that natural compounds came first, and synthetic chemistry, second. Indeed, the potential of healthy food as a "physiological chemopreventive" is enormous. Sulforaphane (SFN), an isothiocyanate in Mediterranean diet vegetables, such as broccoli and Brussels sprouts, was the first compound whose inhibitory effects on histone deacetylase was tested on humans. After ingesting 68 grams of Brussels sprouts, a decrease in histone deacetylase activity was measured in peripheral mononuclear blood cells of healthy volunteers within three hours. While the activity level returned to normal after 24 hours, hyperacetylation of histones was present for at least 48 hours.

The Dalmatian coast also offers wonderfully rich wines with some, like Plavac Mali, known worldwide. Well-balanced intake of good red wine has nothing to do with heavy drinking, which adversely affects our epigenome by silencing our good, cancer-preventing genes. As noted by Croatian islander, Dugi Otok: "Fish keeps me healthy through changing liquids: first it swims in the sea, the second swim is in olive oil, and the third is in red wine."



# Trial and Triumph

## The Mission of *Noriko Inamori*



In Memoriam (1956 - 2013)

[www.iapg.jp](http://www.iapg.jp)  
[www.noriko-inamori.net/index.html](http://www.noriko-inamori.net/index.html)

How do we define strength?

Diagnosed with multiple system atrophy (MSA), an incurable disease, shortly before her 50<sup>th</sup> birthday, and being given but a few years to live, Noriko Inamori transformed her death sentence into a life mission.

The disease continued to worsen. Noriko could no longer speak or move around. In addition to such severe trauma, she was forced to get a divorce and, due to her inability to do housework any longer, was also forced to relinquish parental authority of her five children.

As all that had constituted the pillars of her life vanished before her eyes, Noriko perceived another reality. “I wanted to focus on what I could do, not what I couldn’t do,” she told CENTERPOINT NOW.

She recalled her early love for the performing arts, and in 2009 formed an amateur theatre group. Reflecting on all that humans take for granted, and on the importance of caring for the environment and for one another, Noriko was convinced that through the arts, people’s consciousness could be awakened.

The group’s performances, focusing on works portraying the painful legacy of Japan’s devastating experience with the atomic bomb, such as *SAIKAI —Reunited*, drew thousands of people across Japan. In 2012, the group changed its name from the “INAMORI Theatrical Group” to the “INAMORI Art Project Group,” expanding its scope beyond drama to include other performing and visual arts.

Noriko, whose physical communication became limited to typing with one finger, nonetheless never failed to reach the hearts and minds of all those gathered to learn about her work and join in her mission. Whether at home in Japan, or at the United Nations, where she spoke as an advocate for peace and the rights of people living with disabilities, Noriko remained surprised at the standing ovations she received.

A firm believer in the need for organizations like the United Nations, her message to governments was clear: “I am opposed to enforcement by the use of power or violence for the realization of peace even if it is in the name of any kind of justice. Violence causes violence, because it incurs the hatred of the people afflicted. We are the same family, brothers and sisters, living on this Earth.”

However, her message is not for governments alone. For Noriko, the causes of conflicts—be they border disputes among states, or differences at the interpersonal level—were artificial creations that keep us from accomplishing higher aims. Asked how she believed sustainable development could be achieved, she responded: “We shouldn’t give up our ideals and hope. If your idea can help someone, it is important for you to take action.” Speaking before an audience with the help of an assistant at a gathering in honor of Human Rights Day, Noriko shared: “Through my illness, I was given the opportunity to step outside myself and see more clearly. I regretted not living my life more fully while I could still walk and speak, so I promised myself to not waste my limited time anymore....”

She determined to help others do the same.

# Yogis Beyond Borders

by Dr. Elaine Valdov

“Each time a man stands up for an ideal, or acts to improve the lot of others, or strikes out against injustice, he sends forth a tiny ripple of hope.... These ripples build a current that can sweep down the mightiest walls...”

Robert F. Kennedy, 1966, South Africa

This statement has fueled my footsteps and filled my heart, as I have searched for ways to comfort and help those suffering from life’s profound challenges—from a young mother who lost her husband on September 11, to a law student hearing that a gunshot to his neck has caused him to become a quadriplegic, to girls in Africa, who are unable to go to school, as they walk miles for water daily under the threat of violence and with little hope of a better life.

During my quest to find healing methods for a world in need of transforming its consciousness that allows for profound human rights violations and is in significant environmental crisis, I was called to lecture at the Sivananda Yoga Ashram in the Bahamas. Swami Swaroopananda, one of the main directors of the Sivananda Yoga Ashram, spoke about Swami Visnudevananda’s vision that inspired the Ashram. His vision was “to expand one’s heart, mind and horizons and to discover the joy of our unity and the beauty of our diversity. Swami believed that the source of human suffering came from the level of our consciousness, and that the remedy involved shifting consciousness so as to uplift humanity into higher dimensions. He foresaw this shift, which is taking place now, but he knew that, like all transformations, it could be painful and difficult. “He felt that yoga was here to not only aid in this transformation, but to ease the pain, soothe the transition, and help humanity move forward towards a bright future.”

This philosophy and vision inspired the creation of Yogis Beyond Borders and Yoga Peace Ambassadors. They address essential needs in today’s world, as we strive for a more conscious, compassionate world society. In the midst of global strife, we are aware of a profound deep search for meaning and means to evolve our way of life, both personally and for our fellow human beings.

Yogis Beyond Borders (YBB) takes YOGA INTO THE WORLD, helping individuals and communities heal, transform and grow—aiding in recovery, relieving stress, promoting resilience and providing tools to positively deal with life challenges. Meditation and yoga exercises promote clearness of mind, build internal energy or life force, and help develop compassion, love, generosity, patience, and forgiveness. They revitalize the mind, body, and spirit.

YBB helps bridge the practice of yoga with leadership skills, teaching students to create and participate in humanitarian movements, providing wellness education for the mind, body, and

spirit. Our students have created initiatives, such as taking yoga into centers for cancer survivors in Canada, orphanages in the Bahamas and Colombia, prisons in New York and the Bahamas, among others. We have worked on building eco-peace villages and homes for the homeless. All of these have used the power of yoga to heal. Yoga Peace Ambassadors (YPA), our global humanitarian program, creates initiatives addressing local to global challenges, following the Yogic philosophy of being in conscious service to humanity and our Earth.

YPA helps connect people with their “life’s calling” and creates a way for this to manifest in the world. It helps them find their inner passion for “making a difference,” turns this into ACTION, and helps develop leadership skills to promote people living more vibrant, empowered and fulfilling lives.

Our students have created and designed centers for at-risk teens in the US, eye-clinics in India, medical clinics with humanitarian service projects in Canada, centers for women refugees in California, hunger-relief programs in Africa, humanitarian projects for Caribbean yacht crews, hospital/botanical gardens programs to create healthy and healing environments in Bermuda.

YPA was created for Yoga practitioners, on the premise that those who practice yoga have a depth of spirit, with a strong desire to serve and “give back.” It is made up of persons of all backgrounds and interests, from students to doctors, who have come together to make a better world and be part of a movement that is changing lives.

Each person in Yogis Beyond Borders and Yoga Peace Ambassadors, as Robert Kennedy said, is creating “ripples that build a current that can sweep down the mightiest of walls.” Together, we are creating a new world—a world with a sustainable future that we can proudly pass onto generations of all children, the world over.



Photo, top: Swami Visnudevananda, Founder of International Sivananda Yoga Centres.  
 Bottom: Mahadev.

Dr. Valdov is the President and Founder of Yogis Beyond Borders, Yoga Peace Ambassadors and International Young Leaders Vision Summits, which are affiliated to WCPUN. She is the Former Chair of the Executive Committee of NGOs Affiliated to the United Nations Department of Public Information.

[www.yogisbeyondborders.org](http://www.yogisbeyondborders.org)





# Hope, Peace and a Magical Ride: The INTRA Experience

**"Horses make me feel invincible."**  
*Testimonial from a Rider*

While the camel, the mule, and the elephant have all been modes of transportation for man, the bond, chemistry, and empathy that man shares with the horse is ancient and unparalleled. Primitive humans observed Equus' sensitivity and calmness and its strong sense of its surroundings, while Equus learned how to read and mirror the moods of humans in a way that built a foundation of trust between them. In Ancient Greece, Hippocrates, father of western medicine, described how the horse could be used as a physical exerciser.

In modern times, therapist Anita Shkedi, has used her understanding of the man-horse bond to redirect negativities that influence the health, well-being, and destinies of many individuals living with disabilities, developing a treatment called Therapeutic Riding in 1985 as "...a treatment modality using the unique properties of the horse in planned activities as a primary medium for the treatment of persons challenged by physiological/neurological conditions that influence learning, motor outcomes, cognitive and emotional development, speech and communication, interpersonal relations, and more. The treatment's primary purpose is to improve the health and well-being of people through restoration, remediation, or rehabilitation in order to improve functioning and independence as well as reduce or eliminate the effects of illness or disability." (Shkedi, A, 2010).

Born in Great Britain, Anita's journey to establish an equine assisted therapy program in Israel was a circuitous and serendipitous one. Rami Keich, a friend of Anita's and veteran who had suffered severe spinal injuries resulting in paralysis from the dorsal spine downwards, visited England in 1983. He had been a keen rider in Israel and his fervent desire was to ride again. Being raised with horses and working as a registered nurse in Great Britain for twenty years in the fields of pediatrics, obstetrics and preventive medicine, Anita endeavored to help him take up the challenge.

Through painstaking efforts, Rami was able to ride again. Anita realized her life's calling and set out to establish The Israel National Therapeutic Riding Association, INTRA, as a non-profit organization. Today, over a quarter of a century later, INTRA assists people the world over, including children with developmental delays, children at risk, disabled soldiers, people with Post Traumatic Stress Disorder (PTSD), psychosis, traumatic brain injuries, autism, Multiple Sclerosis (MS), negative social behavior, as well as blindness and deafness, by providing over 1000 rides monthly in a safe, supportive and nurturing environment.

"When I am on a horse, life looks totally different: suddenly my disabilities fall away and disintegrate; suddenly my dreams and desires are within my reach; mostly, I am certain that I'm not alone." INTRA rider

Using paradigms that include new innovative techniques and tasks, the INTRA team has had great success in helping challenged riders improve their lives. Each individual learns, through non-verbal communication with the horse, how to improve body and mental awareness, as well as self-control. As the horse is extremely sensitive to mood states in humans, and has rapid and genuine reactions, he is able to guide the rider to the best response, leading to increased self-confidence and the ability to regulate physical and emotional expressions for the rider. Connecting the challenged riders to the horse, INTRA's therapy stimulates physical and aerobic exercises, imparting body skills, body awareness, and communication. During the ride the horse also awakens intuitiveness, fantasies, archetypal images and symbols. Helping the rider to understand these thoughts facilitates peace of mind and normal reactions to life

experiences. In the company of the horse and the supportive atmosphere of INTRA, the challenged riders begin to feel a sense of belonging.

In 1991 Anita took the first team of riders to the first World Championships for Riding for the Disabled (Paralympics). Their participation has continued, with INTRA challenged riders winning championships in several classes of national dressage. Working with the therapeutic community in colleges and schools throughout Israel and internationally, Anita has trained more than 800 EAA/T (equine assisted activities therapy) qualified practitioners and instructors in therapeutic riding worldwide.



Photos courtesy of Intra.  
www.intra.org.il



# Accessing Other Realms

with Joan C. Roth and  
The Tent Project

The art of physiognomy reading, or face reading, historically practiced in China, has been used in the West for commercial aims, with Fortune 500 companies employing face readers to help select candidates for executive positions. Other heightened capacities of perception, often referred to as “sixth senses,” have been popularized for entertainment purposes. For Joan C. Roth, founder of The Tent Project—a non-profit organization that brings together counselors and healers of myriad traditions to share their wisdom with the public and with one another—rather than entertainment, or profit, the purpose of these abilities is to heal.

Joan never sought to become a spiritual counselor herself. Her journey as a model, actress, producer, and even firefighter, had exposed her to extraordinary people and situations, where she needed to rely on her intuition, but this didn't seem unusual. It was following her recovery from leukemia, that she and those around her noticed a change. “I would be sitting with friends and starting to share information with them. I didn't feel I had control of what I was saying. Eventually I learned that I was practicing face reading. Then, at some point, people would tell me that my face was changing while I was speaking...sometimes resembling other people they knew. Again, I felt no control over what I was saying, but it wasn't until I started speaking in a language that I had never learned, or even been exposed to, that I became determined to understand what was going on.” Joan was accepted to the Arthur Findlay College in the United Kingdom, where only people who are proven “mediums” can study to refine their abilities. Having had her abilities fully tested and scrutinized, upon her return, her personal counseling practice continued to grow. Becoming known for the positive transformative experiences people had when working with Joan one-on-one, or in group sessions, Joan was eventually asked to work as a Spiritual Counselor with a private recovery center, Lifescape Solutions, specializing in trauma and addiction. Lifescape Solutions practices Spiritual Growth Therapy, as well as traditional psychotherapy and hypnotherapy, offering a variety of treatment options to clients suffering from trauma and addiction, many of whom also have criminal records.

After a recent class at the center, Joan described her experience: “The common denominator is abuse and abandonment. All of the young people present have repeatedly been told that they're worthless and will amount to nothing. I mimic the way they've been spoken to and the way they respond, so they can see the behavior patterns from a distance. I also share my own journey; I need to be authentic with them.” As Joan herself was subjected to sexual violence, abandonment, a parent suffering from alcoholism, and other trauma, with her, no topic is off limits. “The pain from the past has a lot to do with secrecy, and being forced to deny what one has lived through. My commitment is to help people live in truth and love themselves.” That day at the center, the topic of conversation turned to drug use and how challenging it was for many of the young people to stay off drugs, when their

parents' and grandparents' counter tops and cabinets are filled with prescription medication. “How can it be healthy to take so many different kinds of pills in one day?” one teenager asked. Most of the youth are also diagnosed as having Attention Deficit Hyperactive Disorder (ADHD) and are required by their doctors to take drugs to focus, or calm down. Joan takes on the challenge of capturing their attention, sharing information that is relevant to their lives in creative ways. “They are adept at multi-tasking and have fast comprehension. They need to be doing more than one thing at a time. When they are engaged, any dismissive attitude that they may have had when walking into the classroom disappears.” The young people's enthusiasm and positive feedback about their classes with Joan caught the attention of other counselors, who began to request sessions with her as well. Determined to help everyone discover and nurture their ability to heal and realize their potential, Joan's evolution in the healing arts continues to unfold and, with it, a world of opportunity to access new insights and embrace the unknown.

*Recognizing the importance of partnerships, under the auspices of The Tent Project, Joan is developing collaborations with other organizations, such as The World Genesis Foundation.*

**The World Genesis Foundation** is a 501(c)3 not-for-profit organization, committed to “Leave no child without hope for the future™.” The foundation began in 1999 with a vision that has grown with the hearts and minds of amazing volunteers, teachers, experts and partners who want to make a difference. The World Genesis Foundation focuses on creating educational opportunities for youth in areas of the world where opportunities may be limited or unavailable today. They believe in one world without borders and that education is key to this vision along with international understanding, social work, arts and culture, the humanities, and social and natural sciences. The educational programs they create and lead are with people and organizations that value knowledge, promote a culture of peace, celebrate diversity and defend human rights. The Atlantykrón Summer Academy of Learning, coordinated by co-founder Sorin Repanovici, is just one example. The academy, celebrating its 25<sup>th</sup> anniversary in 2014, takes place on a small island on the Danube River near the ancient Roman ruins of Capidava, Romania. For 10 days each year the island is transformed into a very advanced learning program with studies and hands-on practice in science, technology, art, culture and communications. “Our children represent one third of our population, but are the future of us all. They will shape our world, our society and each other. When you believe in the mission, and the work comes from the heart, there is no doubt you can create positive change,” says Heather Caton, President of World Genesis Foundation. With a global focus, the foundation works in cooperation with the United Nations Educational, Scientific and Cultural Organization (UNESCO) and partners worldwide to create hope for youth in need.

www.thetentproject.org  
www.worldgenesis.org

# Energy Medicine for Cancer

with Dr. Mayra Rodríguez-Mohamed

People's interest in complementary medicine is not new. Already in 1992, the attraction to complementary and alternative medicine was such that the National Center for Complementary and Alternative Medicine (NCCAM) was created to advance research and education in this field. US President Bill Clinton also formed the White House Commission on Complementary and Alternative Medicine Policy in 2000.

Defined by the NCCAM as “a complementary health approach in which practitioners place their hands lightly on or just above a person, with the goal of facilitating the person's own healing response,” Reiki is another healing method being explored to help people diagnosed with cancer.

CENTERPOINT NOW invited Honorary Doctor in Complementary and Alternative Medicine in the treatment of cancer and International Merit for Educational Excellence awardee, Dr. Mayra Rodríguez-Mohamed, to explain what led her to develop her signature treatment, CancerKi® , Energy Medicine for Cancer: “I learned about Reiki when I studied in India. The practice was developed in Japan and was always passed down from master to disciple through oral tradition. ‘Rei’ means ‘universe’ and ‘ki’ means ‘energy.’ So Reiki is about tapping into the energy of the universe, and clearing the chaotic energy that is created by disease, or that contributes to disease in the first place. I chose to work in this area because I understood the body's ability to heal itself and the mind as a vehicle for healing.... My grandmother used her hands to heal people and clear negative energies. This is called ‘santiguar’ in Puerto Rico. Whenever my sister or I were sick, my grandmother would help us in this way. I knew that I had similar abilities, and since I have little tolerance to see people suffer, I wanted to help cancer patients because there is so much pain and lack of knowledge about how to treat the disease from an energetic perspective.”

Building on her studies with Spiritual Masters, Zi Sheng Wang and Gurumayi Chidvilasananda, Reiki Masters, Medical Qigong Masters and scientists such as James L. Oschman, Dr. Rodríguez-Mohamed developed CancerKi® , or Cancer Reiki® , fusing ancient and modern teachings. “I am not a medical doctor,” Mayra explained, “so I would never purport to provide treatments that are not within my scope. When an oncologist/hematologist called me and said she had been looking for options to offer cancer patients in addition to their conventional treatments, we did a pilot programme offering the services for free to the cancer patients, and the results were amazing.”

In the absence of scientific research, the popularity of complementary medicine including Cancerki® relies primarily on the accounts of patients. Having overseen the pilot programme for cancer patients at the Alejandro Otero López Hospital, in Manatí,

Puerto Rico, hematologist and oncologist, Dr. Rivera, noted that patients who received Cancerki® “dramatically reduced their intake of pain medication. Before they were dependent on them, and now they either do not take them or take a lesser quantity.”

Mayra described further: “The fusion of allopathic and natural medicine is now called integrative medicine. I have been very fortunate that the medical community has invited me to contribute my services, and in some cases, medical doctors have even wanted to learn the methodology of Cancerki® themselves. I formed an educational, not-for-profit organization, The Puerto Rico Reiki Institute, to educate about the benefits of complementary medicine for cancer. We focus on Reiki, but also include other modalities. Medical doctors are trained as scientists, and their original mission to serve, care, and heal has been diminished by a system that has made them into administrators who often don't have the time to talk and listen to patients. If medical doctors and healers work together and share our knowledge with respect, we can provide the patients with all the necessary aspects to promote their healing and improve their quality of life.”

CancerKi® is administered to patients with any type of cancer in combination with the conventional treatments that are used in the management of the disease and can be applied before, during, or after chemotherapy or radiation to relax the patient. Since 2007, Dr. Rodríguez-Mohamed has partnered with the American Cancer Society in Puerto Rico to bring energy management into treatment for the disease there. She now hopes to do so across the United States and worldwide. As a liaison to help educate policy makers in Puerto Rico and in New York City about complementary and alternative medicine, Mayra has been invited to meet with 9/11 responders, and lectures frequently at the University of Puerto Rico Medical Campus, at the Breast Cancer Congress, and on radio and television talk shows. She has also written a book on the subject of Energy Medicine and cancer.

Despite the interest expressed by growing numbers of individuals, most complementary medicine remains uncovered by health insurance. Along with fellow CAM practitioners, Dr. Rodríguez-Mohamed hopes this situation will change. Working in collaboration with medical doctors and patients who attribute their improved livelihoods to their experience with Cancerki® and other complementary practices, Dr. Rodríguez-Mohamed aims to garner support for more scientific research to evaluate the effectiveness of combining allopathic medicine with complementary and alternative approaches, so as to enable greater access for people regardless of their economic means.



Photo of Dr. Rodríguez-Mohamed  
by Annette Chapman.

Facebook:  
Instituto de Reiki de Puerto  
Rico; CancerKi® , Energy Medicine  
for Cancer.  
cancerki@aol.com  
www.cancerki.com



# Meditation at the United Nations

**Interest in mind-body approaches to wellbeing isn't limited to people with disease or disability. Are our lifestyles sustainable? Leading figures within the United Nations recognized early on the need for a holistic approach to wellbeing in the personal and professional aspects of life.**

“The holistic approach to solving problems in a world of interdependence has an equivalent in how we as human beings approach life and the world. Integrating different aspects, breaking down walls and recognizing the mind-expanding and dynamic effects of crossing borders in all respects is relevant both on a policy and a personal level,” said **Jan Eliasson**, Deputy Secretary-General of the United Nations since June 2012, during his 2011 Dag Hammarskjöld Lecture, *Peace, Development and Human Rights - the Indispensable Connection*, delivered in Uppsala, Sweden to mark the 50<sup>th</sup> anniversary of Dag Hammarskjöld’s passing.

He described how Dag Hammarskjöld, second UN Secretary-General, “was a man of nature and a man of culture.... His professional life could not be divorced from his private life. In fact, many of his colleagues asked themselves, ‘how did he find the time to be such a great Secretary-General while having such extensive and time-consuming encounters with nature and culture?’ In my view, his immersion into these spheres, in fact helped make him such a towering leader.... Hammarskjöld was a committed hiker and had a deep attachment to the scenic mountain areas of northern Sweden. He once wrote: ‘We all sometimes need stillness and perspective. We all have our means to find what we seek. I have come to most strongly miss the Swedish mountains which offer solitude and distance, not by flight from reality but by meeting a reality different from professional and daily life.’ He was an ardent student of religious philosophers like Meister Eckhart, and Martin Buber, whose work *Ich und Du (I and Thou)* he was busy translating from German into Swedish at the time of his death.... When Hammarskjöld took the initiative to establish a Meditation room at the UN Headquarters, he decided to make it a room of stillness and simplicity with a big, solid iron ore structure in the half-lit room. Outside the room is a glass mosaic by Marc Chagall. Many thousands of people, including exhausted UN staff, have reflected, slowed down and found peace of mind in this magical room.”

Dag Hammarskjöld’s legacy was furthered by his successor, Secretary-General U Thant. In her 2010 article for *Cross Currents*, “Sri Chinmoy’s Work at the United Nations, Spirituality and the Power of Silence,” **Kusumita P. Pedersen** describes how U Thant invited Sri Chinmoy (1931-2007) to lead meditations at the United Nations. Observing that “while many admittedly take a more skeptical view, there are some who see the United Nations as an archetype of human oneness and an embodiment of the hope for peace, in the conviction that the United Nations is not just an outer, political entity but something more,” Pedersen recalls that “in 1949, a rule was put in place to open and close each year’s General Assembly session by observing ‘one minute of silence dedicated to prayer or meditation.’”(Rule 62 of the Rules of Procedure of the General Assembly.)

Noting that “U Thant, (who) succeeded Dag Hammarskjöld as Secretary-General in 1961 after Hammarskjöld died in a plane crash outside the then Northern Rhodesian town of Ndola... was a devout Buddhist from Myanmar and a lifelong and daily practitioner of meditation,” she further described the nature and purpose of the meditations he invited Sri Chinmoy to hold: “Sri Chinmoy led regular meditations for peace at UN headquarters for thirty-seven years, (with) United Nations staff members, delegates, journalists accredited to the UN, and representatives of NGOs.... One of the most compelling features of those meetings was their silence. The deep stillness might include a musical interlude, but there would be almost no speaking.... Such a practice provides insight and skill for effectiveness, patience and strength to endure, and above all the widest and deepest view of what one is trying to do and for what reasons. Sri Chinmoy stresses that meditation is not for one’s own individual benefit alone and quotes Hammarskjöld’s saying, ‘No peace which is not peace for all.’” (Sri Chinmoy, *The Garland of Nation-Souls: Complete Talks at the United Nations*; Deerfield Beach, Florida: Health Communications, 1995)

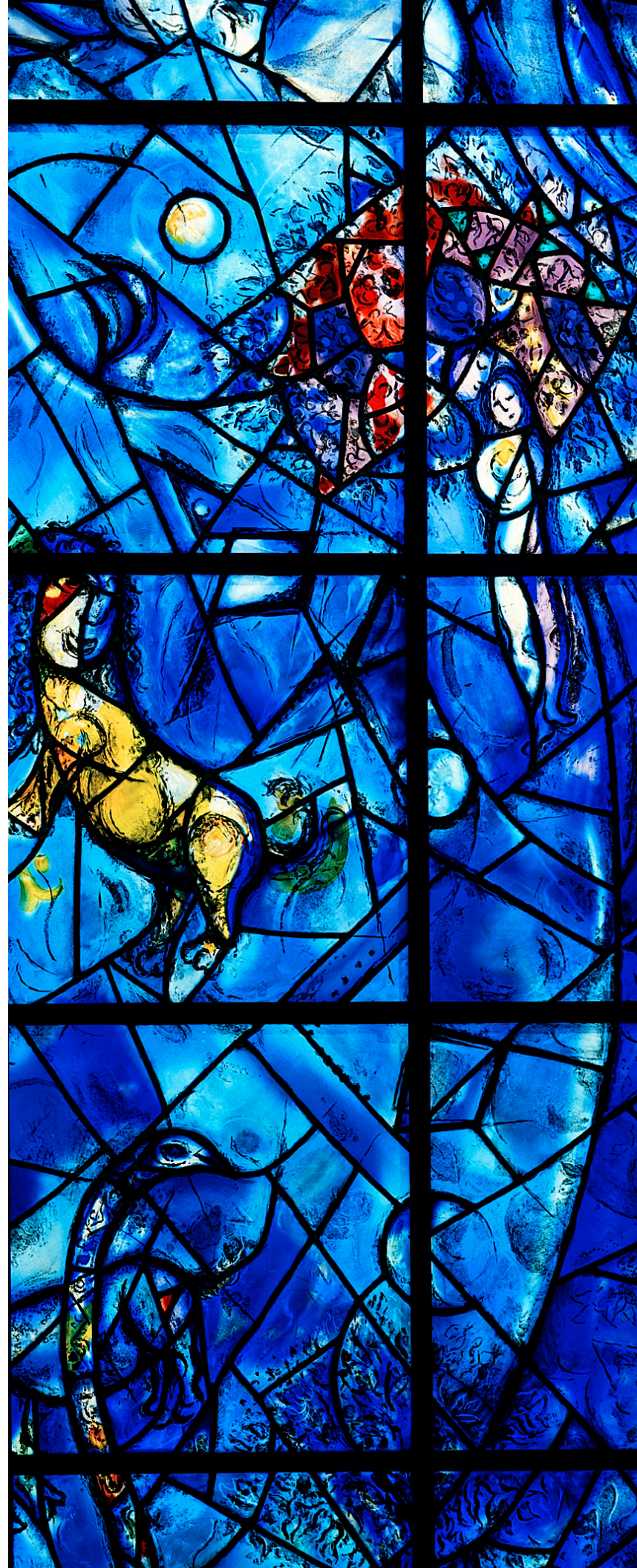

**Pragati Pascale**, Chief of the Development Section at the United Nations Department of Public Information, and UN staff member since 1978, traces her commitment to the UN’s objectives back to her interest in meditation and the encouragement of her teacher, Sri Chinmoy:

“I started meditating for health reasons when I was a freshman in college because I was getting sick from the stress of academic life and was in search of balance. Gradually, I became more interested in yoga and meditation, and when I was about 20 years old, I became a student of meditation teacher, Sri Chinmoy. He believed deeply in the United Nations as an instrument of world peace and the evolution of human consciousness and had been conducting meditations for staff and delegates since 1970. Growing up in New York, I—like most Americans—knew very little about the UN, so the thought of joining the UN would probably never have crossed my mind, but Sri Chinmoy encouraged his students to pursue a UN career and inspired me to begin what has been a great journey.

The UN is a very unique place, and it takes a while to get oriented. I started off working for the UN Yearbook and was happy to have a less responsible job outwardly, so I could focus more on my meditation and inner life. As I had come to the UN less for career reasons, than to serve the UN’s higher goals, I saw the UN from that point of view and didn’t find the politics or bureaucracy so daunting because I wasn’t politically focused. Even when I started doing professional level communications work and became more aware of and involved in the politics surrounding communications, I still brought with me my belief in the UN’s higher purpose and drew upon the strength of my spiritual life as a source of guidance.

I recall an experience many years ago when, while sitting at my desk, I noticed a file cabinet with a stamp that said ‘Property of the United Nations.’ Something flashed in my mind and I asked myself: ‘What is the United Nations?’ I had a kind of inner vision of a little boy in Africa saying, ‘I am the United Nations, you’re working for me.’ It reminded me that, even though we see many imperfections politically and in the outer institution, the inner essence of the UN is profoundly significant. Being independently motivated helps to keep up one’s morale and bring some inspiration to the table.

During my most stressful assignments—such as recently, when I was the Spokesperson for the Rio +20 Conference on Sustainable Development, or previously, as Spokesperson for the President of the General Assembly—having to deal with the media and have answers ready on the spot, I have found it helpful to meditate. I start every workday by meditating for a minute or so and praying to be an instrument for the UN’s important endeavors, before sitting down at my computer. We have a meditation group that meets weekly at the UN, and I’ve also been teaching meditation at lunch for staff and the UN community, as a service, free of charge. It can be done in a very secular way to reduce stress and tap into one’s inner wisdom. Many people have a sense that there is a source of peace inside, if they can take some time for themselves and quiet the mind. Over the years, colleagues, delegates, and friends among UN system staff have been inspired by the idea that meditation can be a foundation for serving the UN and the world. There are times when you’re crazy busy at work and don’t have time to meditate very much, but you come back to it when you can. Working in communications and public outreach, I’ve come to

understand how much the UN means to people around the world. How can we be instruments for peace in the world if we don’t have that within us?”

Could the same question apply to people trained for war? In another meditation group at the UN, led by the Brahma Kumaris, **Samuel Leal**, Marine Officer, and Navy Captain in the Brazilian Marine Corps, who had been seconded to the United Nations Department of Peacekeeping Operations at the time of this interview, described how meditation helped him in his own journey:

“I went to East Timor in 2000, just after the departure of the Indonesians. It was a very tense time with militias still active in the country. I was posted with the volunteer guerilla in a cantonment. The mandate for the UN mission was to do a ‘DDR’ (demobilization, disarmament and reintegration) of the soldiers, but as the volunteer guerilla was a strong symbol of the resistance against the Indonesians, the population wanted them to be recognized as a nucleus for a future Timorese defense force. That was not part of the mandate, so they decided to form a cantonment on their own and reached an agreement with Special Representative of the Secretary-General, Sergio Viera de Mello. There were crises when we were locked in the cantonment and threatened.... We were unarmed—we had our words and the UN beret—but at the end of the day, being unarmed was our protection. I was not regularly meditating at the time, but I used meditation a lot in tense moments; it was a very important tool to stay sane in a country that was devastated, and where we had to meet the challenge of patrolling with a minimal supply of food.

In 2005, I went to Haiti to run the military communications across the country. In Timor, we knew who the enemies were, but in Haiti the stress was permanent because we never knew where a problem would stem from. In these situations, you see the worst of humanity, but also the best. However, the long exposure to these kinds of environments brought about consequences: when I returned to Brazil, one day while leaving the barracks, I had the same reflexes that I had in Haiti—a kind of vigilance, or mental preparation. I experienced anger and a violent temperament.

There is no question that meditation helped me deal with anger and anxiety and enabled me to more clearly see both my potential to help, as well as my deficiencies, and where I need help from others. I come from a religious Catholic family and eventually became interested in meditation because I was looking for self-realization, trying to make the inner self or Christ-self stronger, but my training in the Naval Academy also contributed to my interest in meditation. For example, our training for the shooting team involved a mind-control course with relaxation exercises that are similar to what we do in meditation.

I think meditation centers on UN missions would be a great service. Sun Tzu says ‘anger is the greatest enemy of the general.’ It’s true on the battlefield but also in a broader sense. My personal experience shows me that when you have a leader who is more balanced and cares for subordinates, this has a big influence on everyone and creates the environment to deliver better, no matter what the context.”

Photos clockwise: UN Photo/ AF (Meditation room Reopens, 1957) UN Photo/ Teddy Chen (Stained Glass Window)



# UNCA



UNITED NATIONS  
CORRESPONDENTS  
ASSOCIATION

The U.N. Correspondents Association (UNCA), founded in 1948, is a professional organization that represents over 200 journalists from around the world covering U.N. activities at U.N. headquarters in New York.

The UNCA Awards event, held annually in December, is devoted to encouraging and rewarding excellence in journalism.

[www.unca.com](http://www.unca.com)  
President, Pamela S. Falk  
[contactus@unca.com](mailto:contactus@unca.com)  
212.963.7137

Photography: UN Photo/Milton Grant; Graphic Design: Carlyn Schlechter



## 50 UNITED NATIONS PLAZA

### A New Global Address For the United Nations Community

Introducing 50 United Nations Plaza, an iconic addition to the New York skyline and the first residential building in the U.S. designed by Foster + Partners, whose projects on six continents have pioneered renewable energy solutions and a vital commitment to sustainability in global architecture.

On First Avenue between 46th and 47th Streets, the shimmering modern tower—designed to reflect the inimitable quality of light and life in Manhattan—is the newest condominium from Zeckendorf Development and Global Holdings, LLC. Zeckendorf Development, whose great New York apartment houses include Fifteen Central Park West, is a third-generation family

business with a deep personal connection to the UN. Maternal grandfather Trygve Lie served as its first Secretary-General; paternal grandfather William Zeckendorf, Sr. assembled the land on which the United Nations stands today.

Providing extraordinary privacy, security and serenity in the city, 88 one- to four-bedroom residences are designed for both quiet reflection and grand entertaining. Rare amenities such as gated entry, landscaped motor court, valet parking and a 75-foot swimming pool distinguish this thoughtful architectural statement for the city, always at home in the world.

212.906.0550 | [www.50UNP.com](http://www.50UNP.com)

🏠 Sponsor: G-Z/10 UNP Realty, LLC, 445 Park Avenue, 19th Floor, New York, NY 10022. This advertisement is not an offering. It is a solicitation of interest in the advertised property. No offering of the advertised units can be made and no deposits can be accepted, or reservations, binding or non-binding, can be made until an offering plan is filed with the New York State Department of Law. This advertisement is made pursuant to cooperative policy statement No. 1 issued by the New York State Department of Law file No. CP13-0018.





Where cocktails and cultures converge

The Trump World Tower  
845 United Nations Plaza New York  
212.980.9476  
www.hospitalityholdings.com



YOU'LL  
DIG DAG'S

Patio Cafe  
eat. drink. enjoy

DAG HAMMARSKJOLD PLAZA  
ACROSS FROM THE UNITED NATIONS  
AT 342 EAST 47TH STREET

WWW.HOSPITALITYHOLDINGS.COM | 212.980.9476

Photo by: Candi Obrentz

“Never look down to test the ground before taking your next step; only he who keeps his eye fixed on the far horizon will find the right road.” –Dag Hjalmar Agne Carl Hammarskjold



(upper left) Ambassador of Sweden presides over international peace ceremony.

(upper right) Former World Bank President James Wolfensohn (left) with Australian sculptor Andrew Rogers, creator of “Individuals,” fifteen bronze statues made especially for exhibit in Dag Hammarskjold Plaza.

Greenmarket by Council on the Environment of NYC.

## Sharing the Legacy of Dag Hammarskjold Plaza

### Public land is a valuable asset to be preserved, nurtured and sustained

Frequented by people of all nations and faiths, Dag Hammarskjold Plaza has long served as the historic gateway to the United Nations. In this legendary park, a microcosm of the world can be experienced alongside the challenges of environment, public space and urban planning.

Envisioned by Robert Moses as a majestic boulevard, the land was deeded to the city in 1948. The park was dedicated to Dag Hammarskjold in 1961, the year the UN Secretary General was posthumously awarded the Nobel Peace Prize. Historic marches followed, enshrining the rights to public assembly and free speech, but the plaza fell into disrepair until the mid-1990s when an ambitious renewal plan transformed the park block into a landscape befitting its name. The newly designed, expanded park featured a central plaza with an entrance dome bordered by six fountains and a naturalistic garden. The theme of peace is evoked by quotations of Dag Hammarskjold engraved in the pavement.

Today, this prized 1.5 acres of city land is watched over by the Friends of Dag Hammarskjold Plaza (FDHP), a nonprofit organization whose mission is to beautify and preserve the park, working in cooperation with NYC Parks & Recreation. The seeds of sustainability are taking root as the group forges partnerships with surrounding properties and institutions, spreading the message of park stewardship: public land is an asset to be shared, cared

for and preserved. Only by engaging a broad base of private and public support can such a heavily used park be kept clean, green and inviting. Donations to FDHP fill the formidable gap left by city funding. The community group also brings art, music and dance to the park through its many affiliations. The park is known for its sculpture exhibits by international artists. Missions to the UN, NGOs, tourism bureaus, and arts organizations all have a role to play in bringing cultural diversity to the plaza through public programming and sponsorships.

In 2014, a new luxury condominium designed by world-renowned architect Norman Foster will share the park's boundary line from First Avenue to a retaining wall near the garden entrance. Zeckendorf Development is committed to designing an environmentally friendly landscape that embraces the public space and creates a prestigious entrance to the park's Katharine Hepburn Garden. The park café, under the management of Hospitality Holdings, will offer dining *alfresco* amid lush greenery. The weekly greenmarket continues to grow in size and popularity, promoting environmental sustainability.

As construction scaffolding makes way for a new addition to the Manhattan skyline, the park will experience yet another incarnation. Let's work together to keep the legacy of Dag Hammarskjold alive in this great public space bearing his name.

FOR MORE INFORMATION, CONTACT FRIENDS OF DAG HAMMARSKJOLD PLAZA, 224 East 47th St, Rm. 339 ~ NYC 10017 ~ 212-826-8980 ~ www.hammarskjoldplaza.org



***A Living Library Promotes Sustainable Development And Health  
By Cultivating The Human & Ecological Garden***

Each place-based, **Branch Living Library & Think Park** employs a powerful strategy for making ecological and cultural change, by integrating local resources and involving all sectors of community in learning, thinking and doing. **A Living Library (A.L.L.)** results in content-rich, systemic, landscape designs and greening of the public realm, with integrated community learning programs, that together, solve local problems, while educating all ages in sustainability, health, empathy, and interconnected systems – biological, cultural, technological.

Multiple **Branch Living Library & Think Parks** are underway in California and New York, transforming communities and helping to heal human and land fragmentation, disengagement, and urban blight. A Goal of **Life Frames, Inc.**, NGO sponsor of **A Living Library**, is to develop **Branch Living Library & Think Parks** in diverse communities and nations of the world, all linked together, so we can share and celebrate the diversity and commonalities of our cultures and ecologies – near and far – and better appreciate each other and other species, while healing our home, community, and ourselves.

**In San Francisco, California: OMI/Excelsior, Bernal Heights, & Chinatown Branch Living Library & Think Parks**



**In New York, New York: Roosevelt Island Living Library & Think Park**



***Would You Like A Branch Living Library & Think Park In Your Community ? Please Contact Us !***

[www.alivinglibrary.org/blog](http://www.alivinglibrary.org/blog) | [www.alivinglibrary.org](http://www.alivinglibrary.org) | 415-206-9710 | 212-242-1700 | [bonnieora@alivinglibrary.org](mailto:bonnieora@alivinglibrary.org)  
Bonnie Ora Sherk, Founder & Director | *A Living Library, A.L.L., Life Frame, & Think Park* are Registered Trademarks Internationally | © 2013

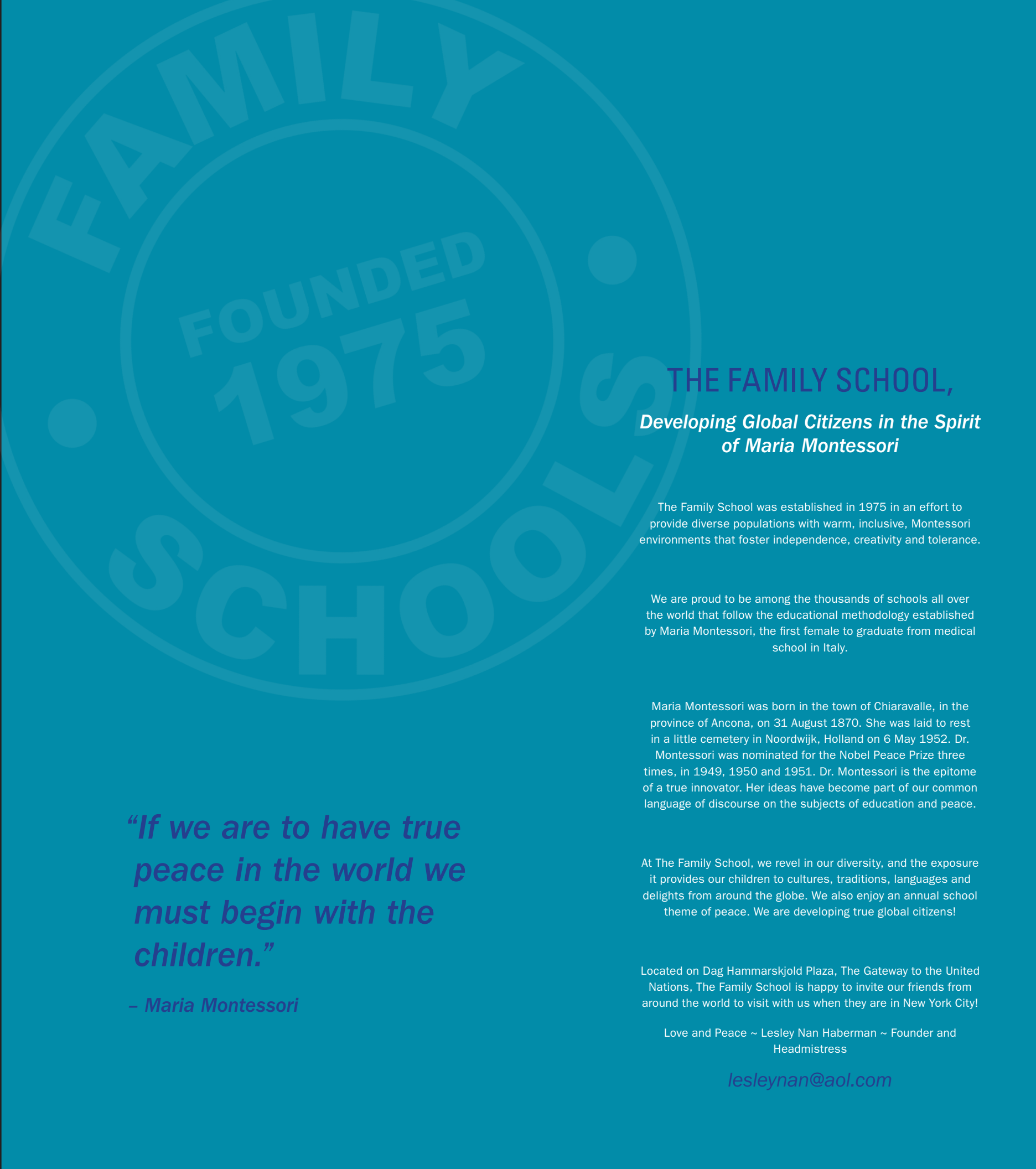

**THE FAMILY SCHOOL,  
Developing Global Citizens in the Spirit  
of Maria Montessori**

The Family School was established in 1975 in an effort to provide diverse populations with warm, inclusive, Montessori environments that foster independence, creativity and tolerance.

We are proud to be among the thousands of schools all over the world that follow the educational methodology established by Maria Montessori, the first female to graduate from medical school in Italy.

Maria Montessori was born in the town of Chiaravalle, in the province of Ancona, on 31 August 1870. She was laid to rest in a little cemetery in Noordwijk, Holland on 6 May 1952. Dr. Montessori was nominated for the Nobel Peace Prize three times, in 1949, 1950 and 1951. Dr. Montessori is the epitome of a true innovator. Her ideas have become part of our common language of discourse on the subjects of education and peace.

At The Family School, we revel in our diversity, and the exposure it provides our children to cultures, traditions, languages and delights from around the globe. We also enjoy an annual school theme of peace. We are developing true global citizens!

Located on Dag Hammarskjöld Plaza, The Gateway to the United Nations, The Family School is happy to invite our friends from around the world to visit with us when they are in New York City!

Love and Peace ~ Lesley Nan Haberman ~ Founder and Headmistress

[lesleynan@aol.com](mailto:lesleynan@aol.com)

***“If we are to have true peace in the world we must begin with the children.”***

***– Maria Montessori***



# International Young Leaders Vision Summits

by Dr. Elaine Valdov

International Young Leaders Vision Summits (IYLVs) are 'Calls to Action' to young leaders around the world, to join together, to help solve the challenges of the 21<sup>st</sup> Century!

Great advances in technology and social media have created monumental opportunities for young leaders to help communities worldwide, working with fellow global citizens. Amazing innovative ideas, creative inventions, and scientific advancements have emerged from young people, stirring the world in awe. This new wave of heightened technology, innovative thinking and creativity is matched by passion to 'make a difference' NOW and enable the world to overcome humanitarian and environmental crises.

In the words of Barbara Marx Hubbard, President of the Foundation for Conscious Evolution; "We are Generation One: the first generation on Earth to be aware of ourselves as one planetary body, affecting our own evolution by everything we do, realizing we can destroy ourselves through misuse of our new powers or evolve ourselves."

We are finally facing the reality that all actions are interdependent. What we do and think affects humanity and our Earth, determining the world's path.

We have the opportunity to create, from our highest potential and creative powers, a world where we evolve and manifest social good for the entire planet—a world of compassion, health, education, peace and prosperity, and environmental sustainability. Our task is to become mid-wives and co-creators of this world.

As said by Kofi Annan, upon receiving the Nobel Peace Prize: "We inherited, from the 20<sup>th</sup> century, the political, as well as the scientific and technological power, which—if only we have the will to use them—give us the chance to vanquish poverty, ignorance and disease."

This requires global consciousness shifting, starting with individuals, where there exists no space for greed and violence. In this global consciousness, the Earth is revered; hunger and poverty are unacceptable, as are the deaths of millions of children from preventable and curable diseases. Though having the "power to vanquish poverty, ignorance and disease," humanity seems caught in century-old behaviors, where trillions are spent on global warfare and starving children aren't seen. With today's technology taking us 'up close and personal' into devastating areas, this is incomprehensible.

Emerging from centuries of violence, humanity needs to overturn archaic mindsets and harmful behaviors that prevent us from realizing our higher potential. Is this possible?

Often out of extreme life challenges, young persons are stepping forward to answer this question. I met a young girl recently, who exemplifies this. She had just arrived in the US to speak at a fundraiser to help build a girls' school in her village. I asked her

what message she wanted to give. She thought deeply and said: "In my village, girls are sold for cows, because families are poor. We are worth more than cows. This must change."

"Strong voices from across the world are coalescing around a new approach: SDGs to help the rising generation set global priorities they will need for a safe harbor for their societies and the planet," said Jeffrey Sachs, Director of the Earth Institute, in reference to the upcoming United Nations Sustainable Development Goals (SDGs), which will add a significant sustainability focus to the existing Millennium Development Goals (MDGs) aimed at eradicating hunger and poverty, promoting health and education, among other objectives.

In this connection, *International Young Leaders Vision Summits* are designed in response to CALLS for an unprecedented need to evolve ourselves and achieve these global priorities, providing a "safe harbor for societies and the planet."

Summits worldwide are geared to provide participants with skills to put visions into action and develop tools to create a socially just world. In the spirit of great leaders Mahatma Gandhi, Mother Theresa, Martin Luther King, Nelson Mandela, and others, we are laying the groundwork for a new generation of compassionate caretakers of humanity and planet Earth.

Our 'Call to Action' asks young leaders to take on the challenge of accomplishing the MDGs, focusing on sustainable development in all areas, and acting as "Generation One," to stop poverty and become global stewards of the Earth.

Summits open with music celebrations and sports events, followed by three to 10-day intensive inspirational / educational programs on world challenges, people making a difference, how to take action, and building leadership and entrepreneurial skills. Post-Summit programs provide year-long program support for developing projects.

To move this crucial agenda forward with great wisdom and undying commitment, Summits are:

1. developing global partnerships and international networks
2. promoting innovative solutions to global challenges through our *International Innovation Forum* and
3. creating the *Generation One Think Tank*, bringing together critical thinkers and action strategists to develop global solutions and action plans.

Our world is full of majestic vistas, from snow-capped mountains and ocean sunsets, to laughing children, and mothers holding their newborns. Equal to these is the sight of young persons working together to help those in need and learning that through their actions, a better world is being created.

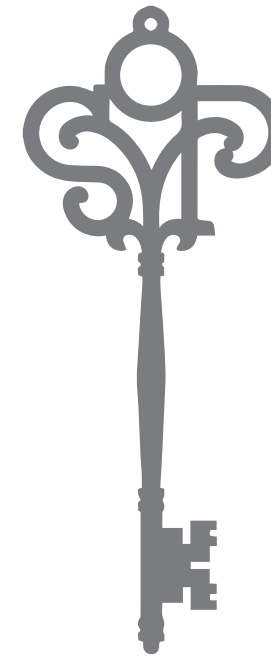

# The Society of Young Philanthropists

*forms the UK division of the World Council of Peoples for the United Nations*



*We are dedicated to incentivising and facilitating the involvement of young current and future 'leaders' in social action.*

*The Society operates in various ways.*

- *Providing a platform for charities and social action projects to make their needs understandable and accessible to our members.*
- *Hosting salon-style dinners to encourage discussion and activity; and larger-scale fundraising events.*
- *Rewarding our members for their philanthropic activity: either volunteering, donating, or fundraising.*

'The Society of Young Philanthropists is doing great things already, and what a fantastic endeavour it is. Charitable giving is all too often reactive, rather than proactive amongst our generation. In our small way, we try to make a difference with the biennial Boodles Boxing Ball, but there is plenty more opportunity for everyone to get involved and to give to charity. Focused charitable events, opportunities for volunteering, and structured philanthropy will only be a good thing for the challenging world that we live in. I wish you every success on what will certainly be an interesting journey...'

James Amos, Director, Boodles

'The Society of Young Philanthropists looks super well thought out and just incredible! I wonder if anyone is doing something similar here as I would love to join myself! Especially given your ties with the WCPUN as well I feel we have so much synergy in terms of our goals... I am really excited about working together and even more I am so excited about your pledge to make giving and philanthropy cooler amongst youth in the UK!'

Anastasia Dellaccio, *The UN Foundation.*

The Society aims to help organizations in every possible capacity. Founding President, Alexandra Abrams (left), and Anna Cottee-Jones, are seen here volunteering to raise awareness and funds for Walking with the Wounded, a UK based charity dedicated to rehabilitating wounded servicemen and women.

theyoungphilanthropists.com

Dr. Valdov, a psychotherapist, is President and Founder of International Young Leaders Vision Summits, Yogis Beyond Borders and Yoga Peace Ambassadors, which are affiliated to WCPUN. She is a Former Chair of the Executive Committee of NGOs Affiliated to United Nations Department of Public Information.

www.internationalyoungleadersvisionsummits.org



COMING TOGETHER FOR VETERANS:

## Joining Hands to make a Nutritional Difference

# THE VETERANS WELLNESS BAR

Nutra-Shield is a New York-based company, founded by former Brooklyn, NY Asst. District Attorney Rudolph Silas, Esq. and Anthony Stone (Owner of ASSIS). These key executives and their partners originally created the concept of manufacturing a healthy bar made solely of Dark Chocolate, Raspberries, Blueberries, Almonds, Honey, Coconut and Rice Crisp... antioxidants with health benefits ranging from reducing the risk of heart disease, providing cancer-fighting properties, boosting immunity, protecting against chronic diseases, preventing infection and accelerating healing, to slowing the aging process.

In joint venture partnership with Veterans support organizations, Nutra-Shield's latest product line is designed to provide an array of chocolate products for fund-raising events, direct sales, catalog sale and Internet sales worldwide, giving independent chocolatiers space for presentations to sell their own products through veterans' organizations from different wars.

The Nutra-Shield™/Forvets™/Veterans Wellness Bar™ is as delicious as it is nutritional, with a recipe developed by a leading culinary institute to create a bar that contains nothing but Mother Nature's antioxidants in virtually every ingredient and is gluten-free, contributing to developing healthy and balanced dietary habits.

For the Veterans, this endeavor is an opportunity to earn money, find employment, invest in and take part in the promotion and sale of a wide array of chocolates manufactured by a large number of leading chocolatiers. Furthermore, under the "Forvets" brand, independent retail stores are being launched that will be jointly operated by Veteran owners and primarily staffed by Veterans.



rsilas@optonline.net  
www.avcf.us



## Transforming the experience of war into a platform for peace,

by William C. Needham, Jr., Co-Chairman  
Veterans for World Peace and Reconciliation

“Why do we fight? We both want the same things: family, love, children, work.”

- Margaret Mead

Across the world and throughout time, young people test themselves physically, emotionally, and psychologically, to maximize their collective abilities in preparation for war. Only afterwards, when the exhilaration has ended and both sides have harmed and diminished what could have been a higher order of human destiny, do veterans of war understand the tragedy of it all. After experiencing the horror, it is they who are among the most active in creating programs to raise awareness as to why war is not a solution.

Those not killed in battle are often maimed for life, whether their scars are visible to the eye or not. Pain and trauma are not sustainable, as shown by significant suicide rates among veterans in recent times. Often, veteran programs are aimed primarily at short-term job attainment. Despite greater knowledge about Post-Traumatic Stress Disorder (PTSD), holistic support for veterans is still lacking.

Formed in March of 2012, Veterans for World Peace and Reconciliation is a program dedicated to advancing the voices of the world's veterans in peace and reconciliation processes, as well as to ensuring their participation in veteran suicide prevention projects, public education symposia in universities, and the development of "For Vet" businesses to provide veterans with sustainable employment and ownership opportunities.

VWPR recognizes that, while soldiers may return to different lands, they often face the same tribulations and hold the same hopes. Beyond addressing immediate pragmatic needs, the world's veterans can be a force for peace and reconciliation, helping to prevent conflict. They, better than anyone, know that by talking to one another, walking together and developing personal bonds, it becomes far more difficult to do harm.

Veterans for World Peace and Reconciliation is in association with the Rotary Club of North Hills, New York.





## Live, Love and... Dine Out! The New York State Latino Restaurant Association

by Juan Esteban, Founder

According to the Mayor's travel office, in 2012, New York City had 52 million visitors. For tourists and locals alike, navigating the maze of fast food restaurants, diners, street cart food, as well as fine dining, can be a significant part of the New York City experience.

Renowned restaurants offering Italian, French or Spanish cuisine are usually the destination of choice, with their decades of established presence and prestige. Realizing that lesser known, but equally refined culinary traditions are often overlooked, in October 2012, Rafael Anaya and I founded and launched the New York State Latino Restaurant Association (NYSLRA) with the mission of expanding opportunities for Latino-owned and themed fine dining restaurants.

With over 20 countries of Latin or Hispanic heritage, this represents quite a gastronomic journey!

In conversation with Armin Torres, owner of Peruvian and fusion cuisine NYSLRA restaurant member, Raymi, located in the Flatiron District, he described the origin of his passion for Peruvian food—the 24,000 varieties of potatoes available in Peru, the Indigenous people's knowledge of moon cycles, architecture, science and farming, the unique terrain, oceans, climate and wildlife. He also spoke about the diverse cultural influences in Peru, and how Asian immigrants from Japan and China, settlers from France and Spain, Africans who were brought to Peru as slaves, and Indigenous populations interacting over the past 500 years, created one of the most exquisitely sophisticated, complex cuisines one can imagine.

At La Pulperia, in the Theater District, owned by Chef Carlos Barroz of Argentina and restaurateur Victor Medina of Mexico, one can enjoy a combination of "rustic" raw bar and fine dining. With a decor and ambiance reminiscent of seaside villages of years gone by, an elegant presentation of food and outstanding service, along with the Chef Barroz' house specialty of fish ribs made from Brazilian Pacu fish, the Pulperia experience is truly unforgettable.

The New York State Latino Restaurant Association celebrates both the unmistakable qualities that are common to all Latin countries, as well as the uniqueness of each country and its cuisine. We are honored to introduce our vast cultural heritage to new communities and to help enrich its repertoire with elements from other regions of the world. All are invited to join in this extraordinary discovery by contacting us, and we'll make recommendations that are sure to delight.

## The Hispanic Information and Telecommunications Network: Empowerment through Educational Media and Entertainment

When José Luis Rodríguez first arrived in New York City in 1973, he thought it was going to be a short stint...three months tops to make money, and then return to his native Luquillo, in the northeast coast of Puerto Rico. Today he is still in the city, this time sitting in a spacious office in Brooklyn's Navy Yards overlooking the East River.

His desk is cluttered, but the shelves and window sill have neatly placed pictures of his family (two daughters, two grandchildren), awards, and odd curios: a pair of iron mini skates and an Hugo Chávez action figure that former governor of New Mexico Bill Richardson gave him, and a bookshelf with books about technology and education.

Rodríguez is the CEO of the Hispanic Information and Telecommunications Network, Inc. (HITN), the first and only Spanish language public TV network in the US. He spearheaded the organization in 1983, along with a group of New York based Latino educators, with the mission to advance the educational, socioeconomic, and cultural aspirations of Latinos in the US and Puerto Rico ("back then we said Hispanics," he says).

The early 1970s, when Rodríguez first became involved in education in New York, were politically rocky times. He joined a program in Lehman College called Recruitment and Training for Spanish Speaking Teachers, and then went on to pursue a masters degree at the Teachers College of Columbia University. He became an activist in the Lower East Side of Manhattan. According to him, there was a school board election that racially discriminated against Latinos. For the first time in the history of the north, an election was thrown out because of racial discrimination. The superintendent was let go, along with 11 principals and about 100 Latino teachers. "So I decided to change careers," he says. Rodríguez then became a distributor of educational materials, published a couple of children's books and, at 25, became the youngest principal of a New York City school. He was elected Delegate of the United Federation of Teachers and, along the way, gravitated towards telecommunications.

But an educator at heart, Rodríguez continued to pursue his interest in education. The question now was: How to use technology (at the time telecommunications) to advance the educational aspirations of the Latino community?

Together with a group of people who shared his interests, Rodríguez applied for a Department of Commerce grant. The group had identified some spectrum frequencies that were available for educational purposes.

"We applied for them throughout the country, and the rest is history," recalls Rodríguez about the beginnings of HITN, the first educational Spanish-language broadcaster in the country. In 1987 HITN became the largest license holder of spectrum in

a band that has become the primary band for 4G services, not only in the United States, but also worldwide.

As technology evolved, so did HITN. Today, companies like Sprint, Verizon, and AT&T use that same spectrum to connect devices, including smart phones, computers, and tablets; and HITN reaches about 40 million households through different platforms in the US alone.

Although not affiliated with the PBS system, HITN follows the same format and is bound by some of the same restrictions, such as not selling commercial space on its air. Its programming couldn't be more different from other Spanish-language TV networks either. Instead of scantily clad women and telenovelas, HITN aims to educate Latinos and address the issues relevant to that community. Rodríguez has also formed partnerships with other organizations in the US and around the world, including Spain's Educational and Cultural Ibero-American TV or ATEI, and several public television networks in Latin America.

HITN developed a sustainable model by becoming the spectrum's holder.

With a grant from the federal government, it has also developed multiplatform content that is aligned to the US school curriculum for children ages 3 to 5.

"We are in the same position Sesame Street was when they started developing videos for educational purposes. Now we are developing educational content but for new media," he says.

Through its partnership with Spain's ATEI, HITN is currently using the popular Spanish cartoon character, Pocoyó, to teach English to preschoolers, but Rodríguez believes the same approach can be used to teach different languages to children all over the world. "Thirty percent of our budget goes into research. We're developing a pedagogy approach targeted to this age range that has been proven to be effective."

Rodríguez has found a way to marry his two main interests, education and technology. In addition to leading HITN, he serves in the New York Education Reform Commission and is a member of the Communications Security, Reliability and Interoperability Council (CSRIC). He has also served as Chairman of the Latinos in Information Sciences and Technology Association (LISTA) and is a co-founder of the National Association of Independent Networks (NAIN).

The affable, soft-spoken Rodríguez grows passionate when talking about the educational needs of the Latino community in the US, especially children. As he points out, Latino preschoolers represent up to 50 percent in some states.

"[Preschoolers] are the future of this country. We must empower our people."



Educa y Entretiene





# Aesop Realty - A Spirit of Service,

by Kathy Thompson

## *Welcome! Willkommen! Bienvenue! Kalosorisma!*

At the gateway to the United Nations, one can find countless ways to greet our friends and neighbors. I have discovered in almost three decades of living and working in this wonderful City of New York that the greeting that crosses all cultural strata is good will and felicity.

I arrived in this city of immigrants like so many before me; the place that I originated from is Georgia, in the southern region of the United States. Goodwill and felicity, kindness and forbearance were my welcome to New York from peoples of all walks of life.

I have spent my entire career in the real estate industry making every effort to infuse those qualities into my business. New York real estate is not for the faint of heart; and my success in it is due in large part to client loyalty in a complex, ever-changing field.

To my delight I have found that, by combining my professional knowledge with a personal interest in attaining my clients' goals, my network of clients has become a network of good friends throughout the years.

Whether it is handling a residential rental or sale, a commercial purchase, an overseas investment, property management, or a foreign nation's needs, the combination of integrity, discretion and genuine commitment to the clients' success cannot be overstated.

To be able to carry forward those ideals into the public realm of service to others and to the community at large, is a goal I have held for some time now. To that end, I have looked around my city, finding countless ways to be of service—to the homeless community, to the parks and public realms, and as a member of our district's community board.

I believe that the need to be of service to others is an ingrained, deep-rooted desire in all peoples, and one that can be fulfilled in each one's own backyard, no matter where their piece of real estate is located around the world.

Friend, neighbor, client and associate, please join me in reaching across cultures and urbanity to be the force of good will and felicity for others in the same way that my own early experiences have defined my life in this city.

dZi is an American Minority owned company that provides sustainable Internet Presentation Services.

We specialize in presenting you, your firm or organization with interface applications that make a statement to the world of your presence.

In addition, we provide the following services:  
Web Interface & Applications, Social & Internet Marketing, Graphic Designs and Photography & Video Productions

Whether you are in a village, town, municipality or a government, we present you to the world.

**Sustainable World Wide Presentations = dZi**  
One Stop Solutions in any language globally

**dZi**  
**DZi DESIGN GROUP**

www.dZigroup.com      Tel: 800-768-9635      Skype: dzi group

Kathy Thompson  
Aesop Realty  
246 East 46th Street, Suite 7N  
New York, NY 10017  
646-660-1685  
KathyThompsonNYC@gmail.com

www.KathyThompsonNYC.com



# About A Day in the World

by Marika Stolpe and Jeppe Wikström



"It is vital to see beyond isolated news events, to try to understand context and learn about each other. And photography is a wonderful communication tool, transcending the barriers of age, language, culture and gender. Photography connects—showing pictures of your loved ones, your children or grandchildren instantly brings you closer to each other. Photography educates us—we see things from other parts of the world and learn about the lives of our brothers and sisters. Photography captures history—our stories deserve to be told."

- Archbishop Desmond Tutu,  
Member of the Global Advisory Council of Aday.org

Aday.org, the largest single-day photographic documentation of everyday life, took place on 15 May 2012. People all over the world took part to produce a visual record of humankind, simultaneously sharing their own lives. We, in Aday.org, encouraged participants to reflect on the basics in our lives.

Together, people from all over the world created a gigantic chronicle of our lives, merging countless perspectives. Exactly 63,294 people from more than 190 countries signed on. On the day, millions of pictures were taken for Aday.org—by both professionals and amateurs—and more than half the participating photographers were women. Almost a hundred thousand pictures were uploaded. One thousand images were chosen for the book *A Day in the World* and for a number of exhibitions. The selection makes no claim to be a complete representation of life on Earth, but is a mirror of what was submitted.

We wanted to highlight the evolution of photography and the value of the simplest images when created with a purpose. The Internet provided the platform for global reach, and digital technology has changed the way we shoot: for example, only one percent of the submitted images were taken with pre-digital cameras, while 20 percent were taken with mobile phones.

Aday.org is about sharing everyday life, a kind of self-portrait of humankind. All submitted images will be preserved for future research as time capsules in several institutions around the world—the first to accept this donation was the National Archives of Sweden and the University of Cape Town in South Africa. All contributing photographers have thus sent a message to the future: this was us, this is what we did, this was our world on 15 May 2012.

## Colophon

This is the 25<sup>th</sup> issue of CENTERPOINT NOW.  
The fonts used were ITC Franklin Gothic Std and Univers.  
The coverstock is Kraft paper 290 gsm and the text paper is Tauro 120 gsm FSC uncoated paper.

## Printing

CENTERPOINT NOW was printed at Graphicom. Graphicom Group (Vicenza, Italy) is dedicated to making the process of producing books as environmentally sustainable as possible, and therefore is compliant to ISO 14001 environmental certification and policy.

Graphicom maintains eligibility for the FSC chain of custody for the use of paper coming from sustainable forestry.

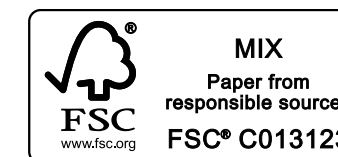



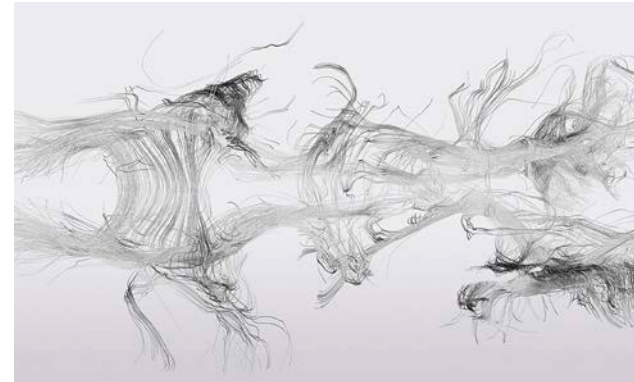

Cover Artist

# Michael Najjar

Michael Najjar is a German artist, adventurer and—future astronaut. Born in 1966, he has lived and worked in Berlin since 1988. His work is shown in museums, galleries and biennials around the world.

He works with Photography and Video. The focus of his work is on key elements of our modern society driven and controlled by computer and information technologies. Najjar, widely seen as a visual futurist, transmutes science, history and philosophy into visions and utopias of future social structures emerging under the impact of cutting-edge technologies. The fusion of realistic elements with fictitious realities, is a recurrent hallmark in his work, which is usually composed in thematically focused series. Najjar demonstrates the potential of the photographic image, capable of making visible what is normally invisible to the human eye. His work visualizes what very often is beyond the limits of our perception, unveiling what is hidden under the surface of what he calls “telematic society.”

Michael Najjar is currently working on a new series entitled “outer space.” The “outer space” work series deals with the latest developments in space flight and the way they will shape our future life on earth and in earth’s near orbit. We are now on the threshold of a new era in space flight heralded by a paradigm shift in aeronautics research and the aeronautics industry, but above all, by the emerging sector of commercial space travel.

One central theme in this series will be Michael Najjar’s own experience of space flight. As one of the pioneer astronauts of Richard Branson’s Virgin Galactic, he will be embarking on SpaceShipTwo in one of its 2014/2015 scheduled flights, where he shall be the first artist in space.

Top, left:  
“spaceport”, 2012  
work series “outer space”  
size: 202 x 132 cm / 102 x 67 cm  
technique: hybrid photography, lightjet-print, aludibond,  
diasec, custom-made aluminium frame  
courtesy of the artist, © michael najjar

Cover:  
“space debris I”, 2012  
work series “outer space”  
size: 202 x 132 cm / 102 x 67 cm  
technique: hybrid photography, lightjet-print, aludibond,  
diasec, custom-made aluminium frame  
courtesy of the artist, © michael najjar

Inside cover:  
“the sublime brain [of sherin and michael]”, 2008  
work series “bionic angel”, 2006-2008  
size: 300 x 180 cm  
technique: hybrid photography, lightjet-print, aludibond,  
diasec courtesy of the artist, © michael najjar





