



# Cross-hemispheric Connectivity Benefits Cognition in Normal Aging and MCI

Mariam Hovhannisyanyan<sup>1,2</sup>, Olga Lucia Gamboa Arana<sup>1,3,4</sup>, Daisy K Banta<sup>1,2</sup>, Courtney A Crowell<sup>2,3</sup>, Amanda Szymanski<sup>1,2</sup>, Marty G Woldorff<sup>1,3,4</sup>, Simon W Davis<sup>1,2,3</sup>

<sup>1</sup>Center for Cognitive Neuroscience, Duke University, Durham, NC, USA; <sup>2</sup>Department of Neurology, Duke University School of Medicine, Durham, NC, USA. <sup>3</sup>Department of Psychiatry and Behavioral Sciences, Duke University, Durham, NC <sup>4</sup>Department of Psychology and Neuroscience, Duke University, Durham, NC

the electric dinosaur

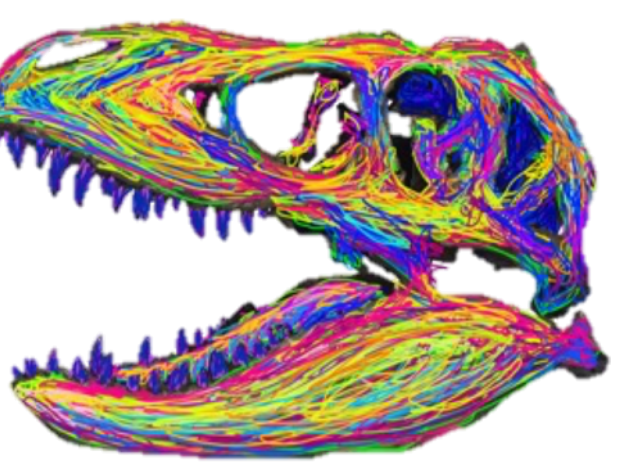

## Background

The left and right cerebral hemispheres collaborate to complete complex cognitive tasks and healthy older adults often take advantage of this mechanism to offset the deleterious effects of aging on cognition<sup>[1]</sup>.

Bilateral patterns of fMRI and EEG activity are associated with increases in memory and attention, suggesting a compensatory mechanism<sup>[2]</sup>.

Most of these theories are based on correlational data. Here we use bilateral TMS delivered online to PFC to answer the following questions:

Is it beneficial for the hemispheres to work together? Can we test this causally with TMS? Does bilateral connectivity mediate performance on memory and attention tasks?

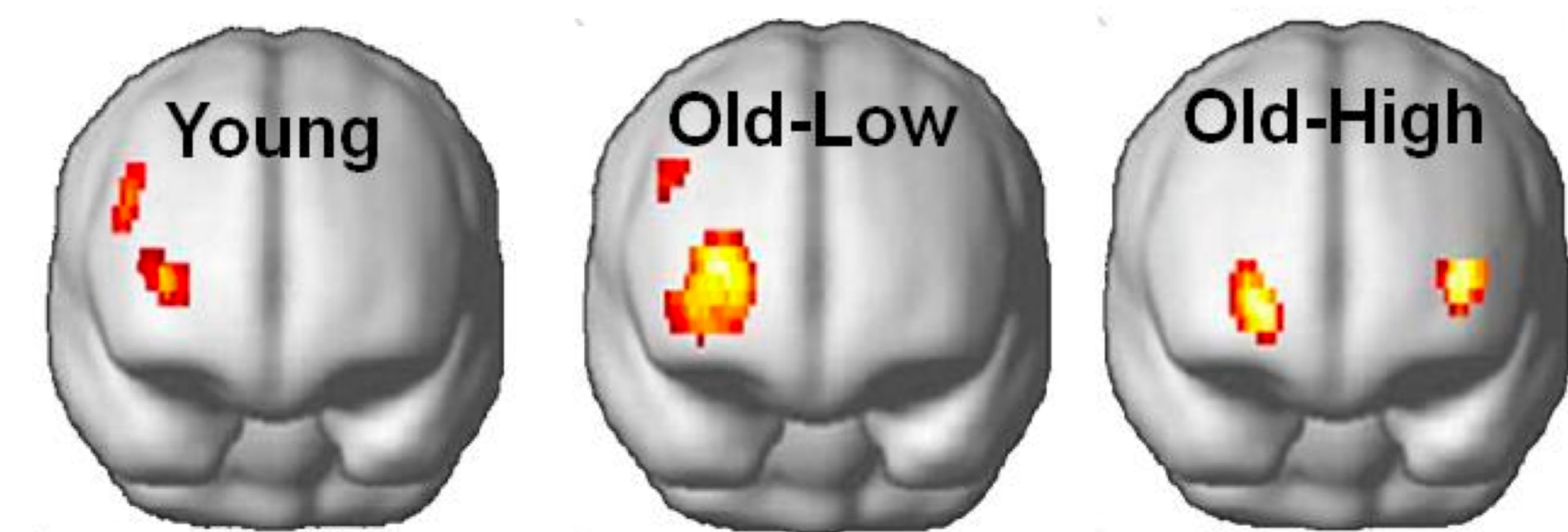

## Study Design

**Session 1**  
DTI Targeting @ Cross-hemispheric sites

**Session 2**  
rTMS @ Target Site during rest

**Session 3**  
rTMS @ Target Site during task

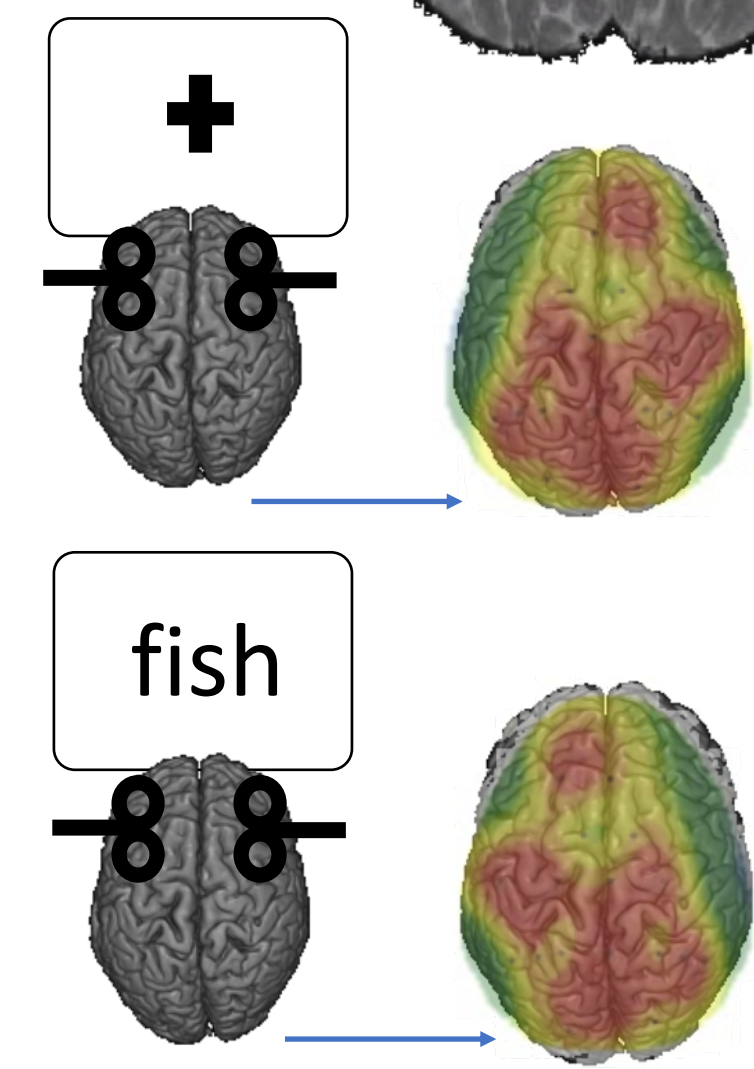
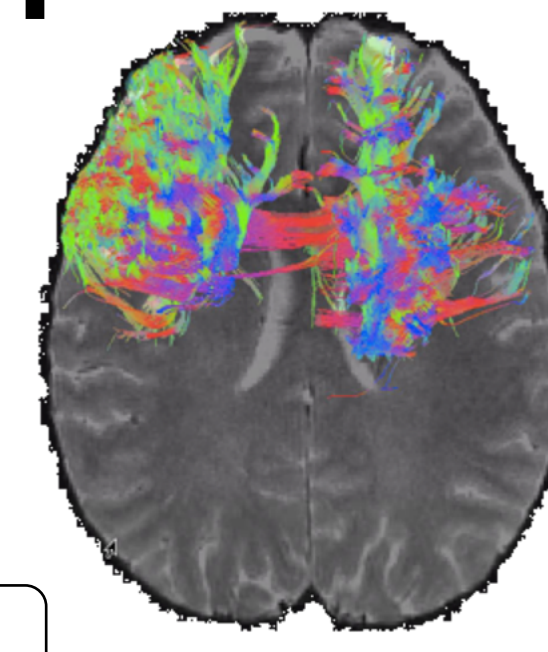

**MRI session:** 42 participants had structural scans, including high-resolution DTI. Ss complete NIH toolbox/MoCA/NACC outside of the scanner.

**TMS + EEG (non-task):** Of those 42 participants, 13 of them underwent TMS-EEG procedures.

**TMS + EEG (task):** 13 participants underwent the same TMS-EEG procedures while they performed domain judgement encoding task followed by a memory task.

### Wiring Diagram for dual-coil TMS with EEG

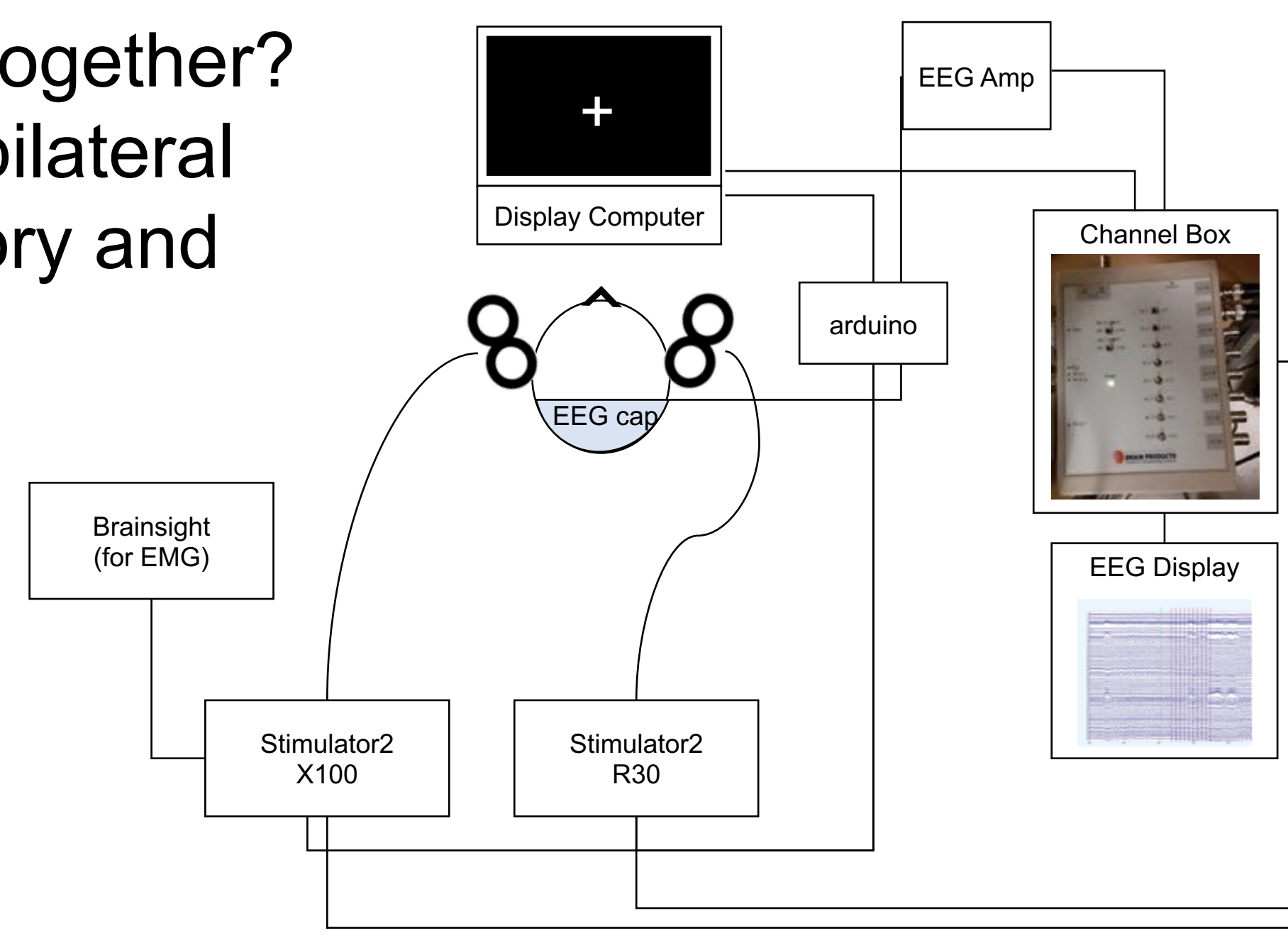

### Simultaneous Bilateral TMS-EEG Set-up

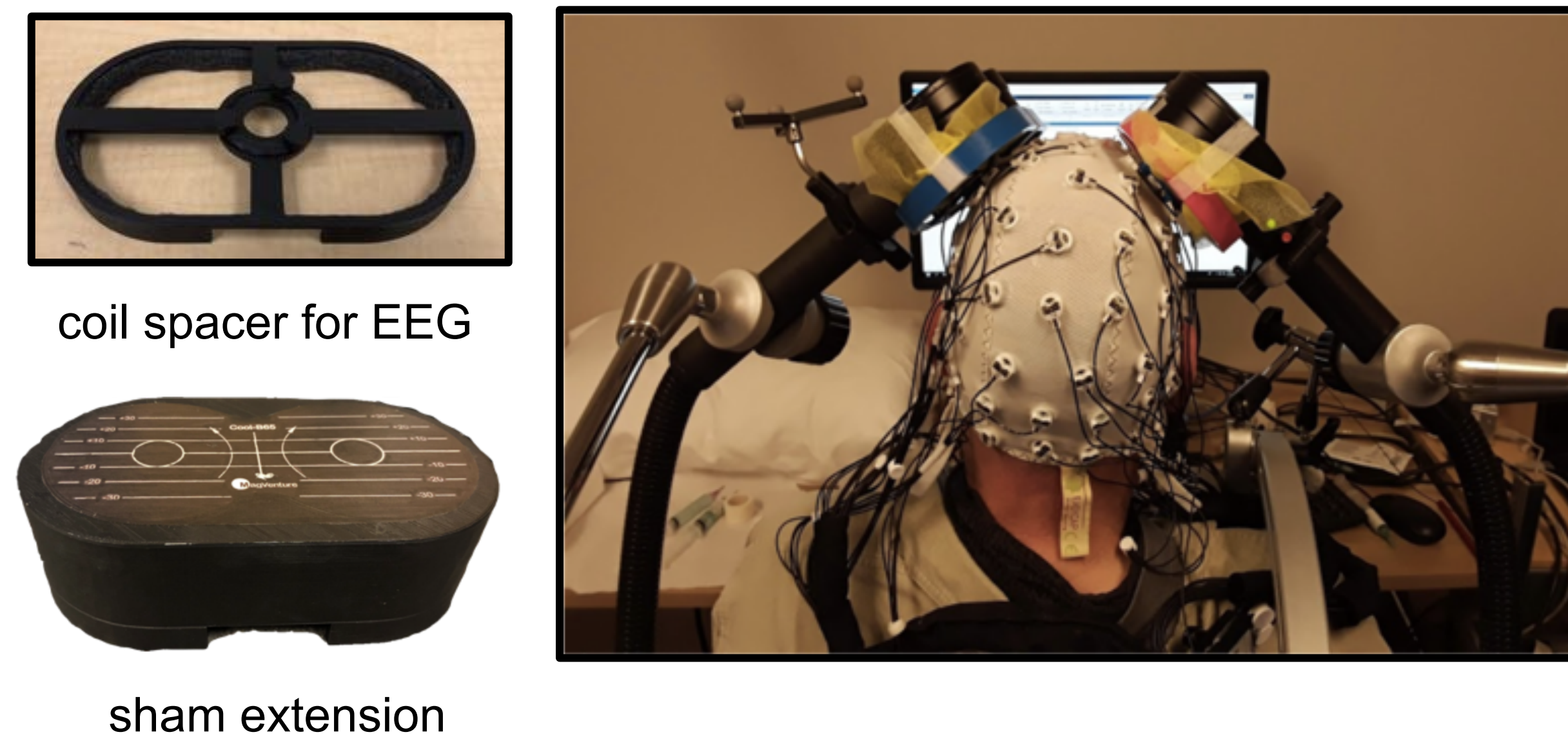

## Does bilateral connectivity mediate memory performance?

### Structural connectivity

Bilateral connectivity in frontal regions predicts performance selective to fluid (but not crystallized) intelligence scores. These effects are largely driven by relationships working memory tasks and not any other task (via NIH toolbox).

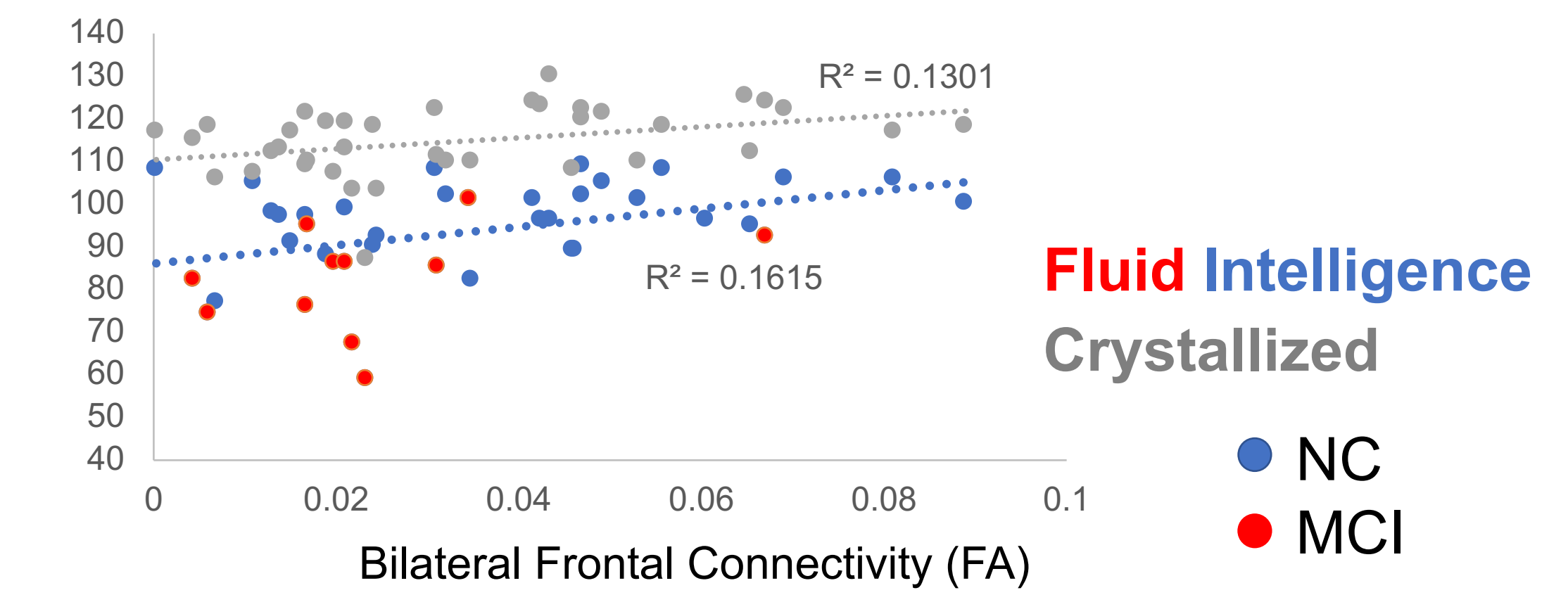

Effects are selective to Bilateral Frontal Connectivity.

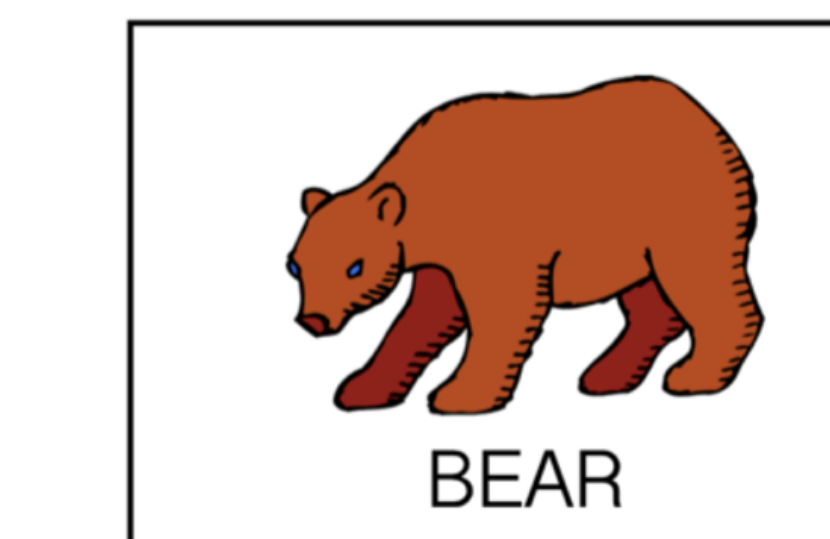
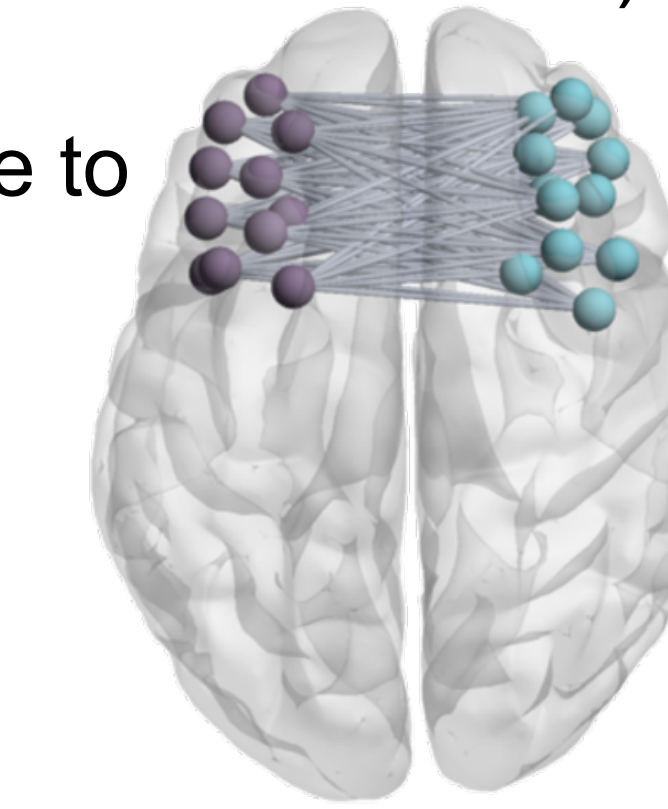

Size Sorting Task (A measure of Working Memory)

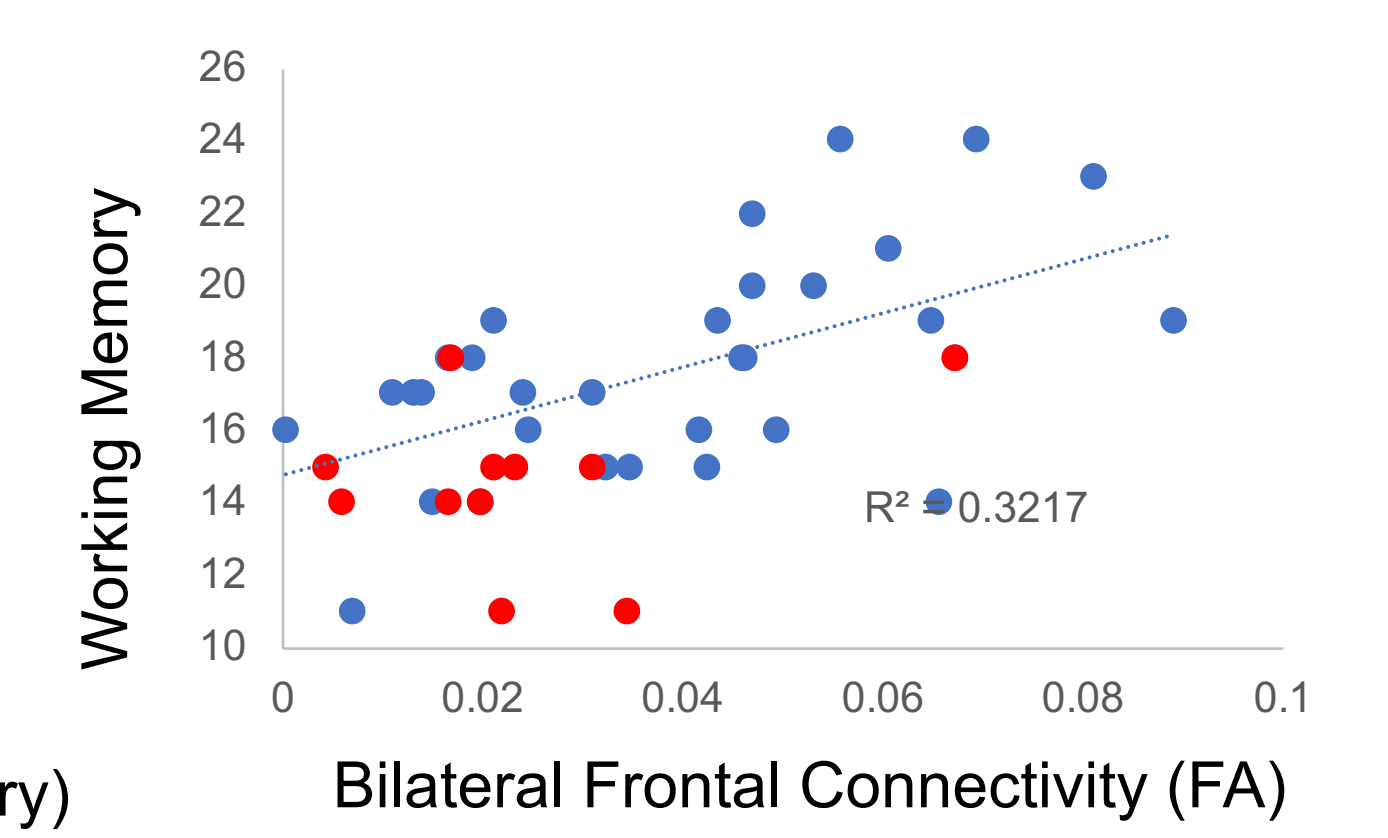

## TMS-induced effects on behavior & neurophysiology

### Encoding

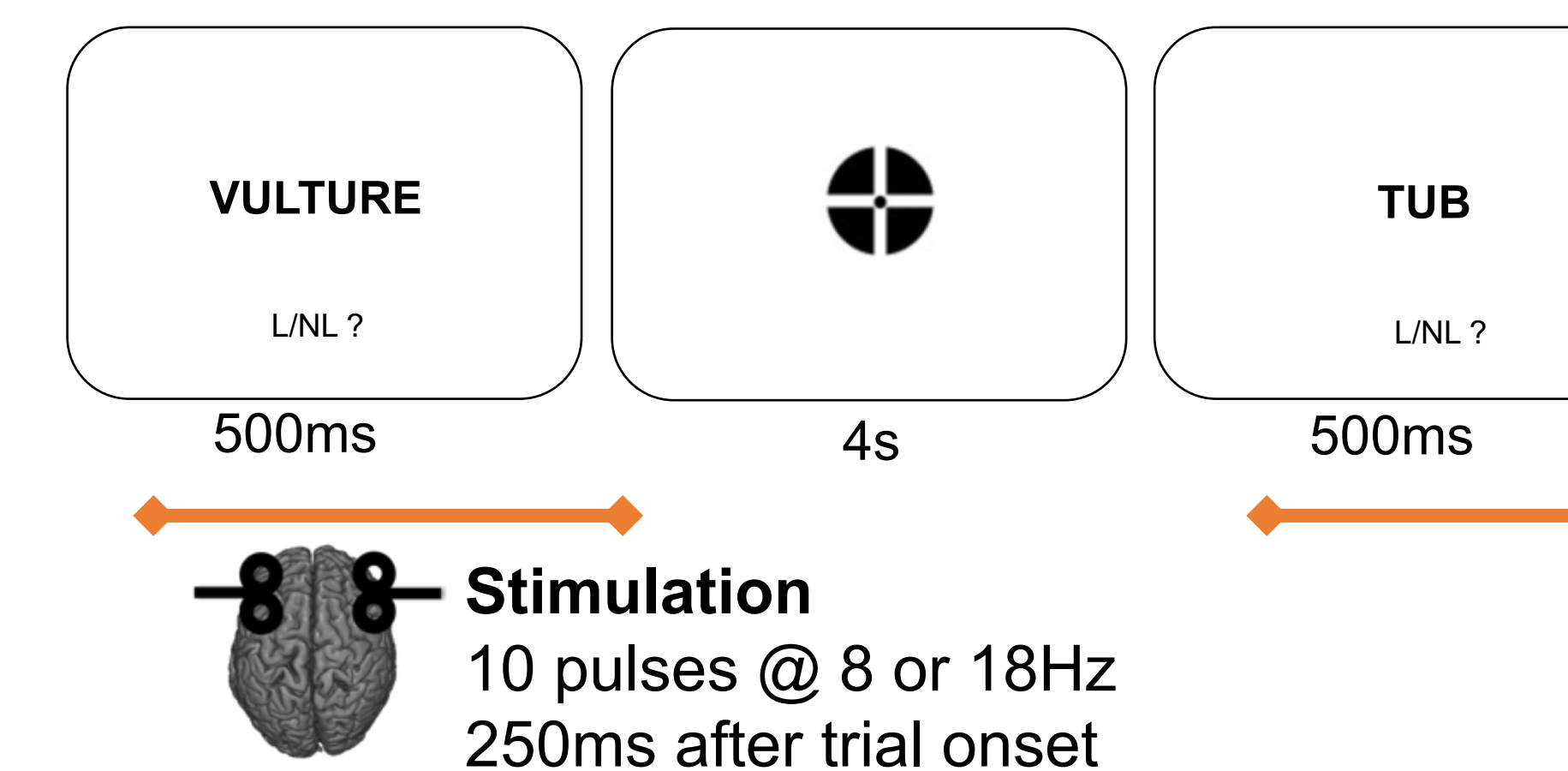

### Retrieval

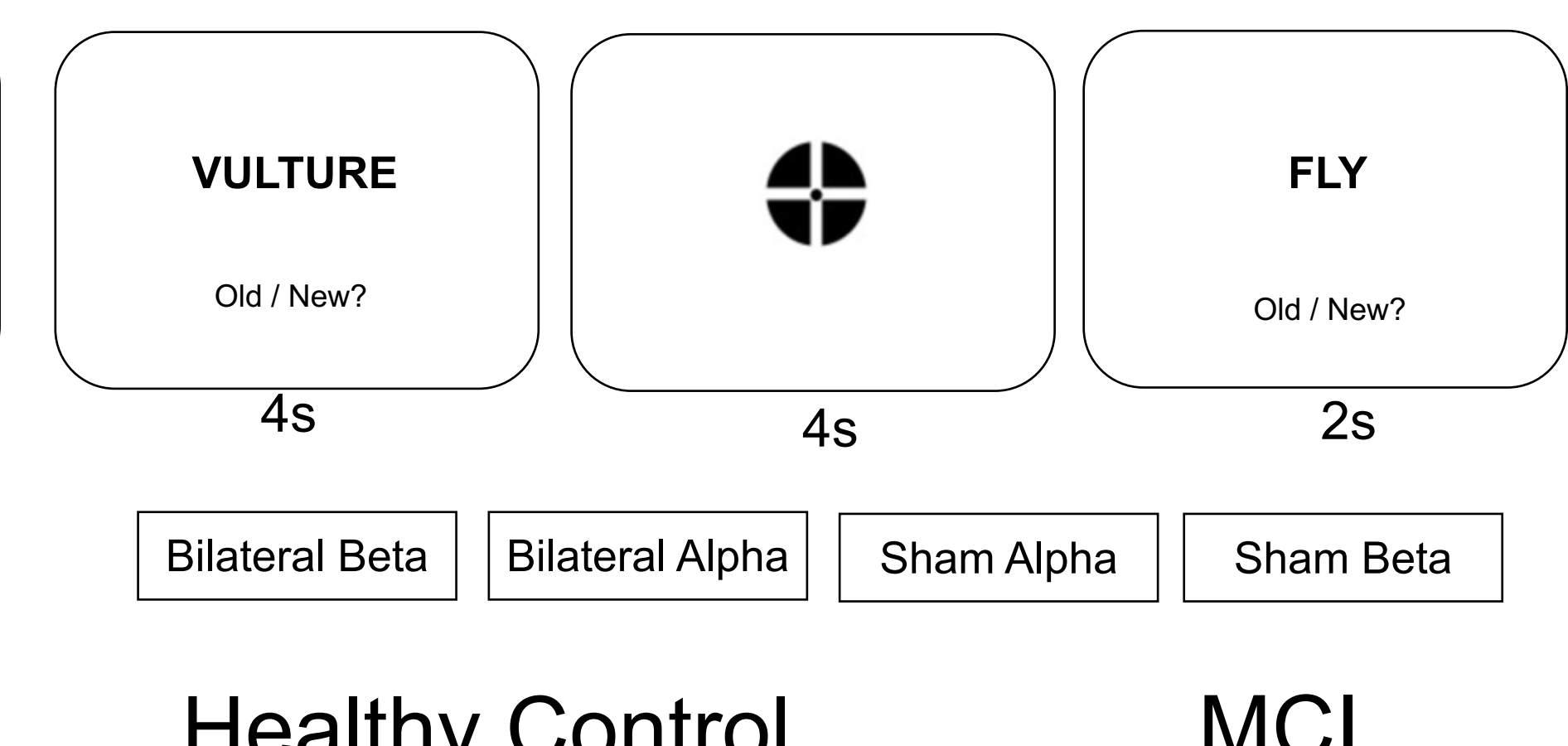

In our sample of healthy older adults (n=14) and MCI (n=4), memory varied by TMS condition.

Memory accuracy (d') appeared to show a selective benefit for bilateral alpha TMS in HCs (t = 2.11, p = 0.051), and bilateral beta TMS in MCIs.

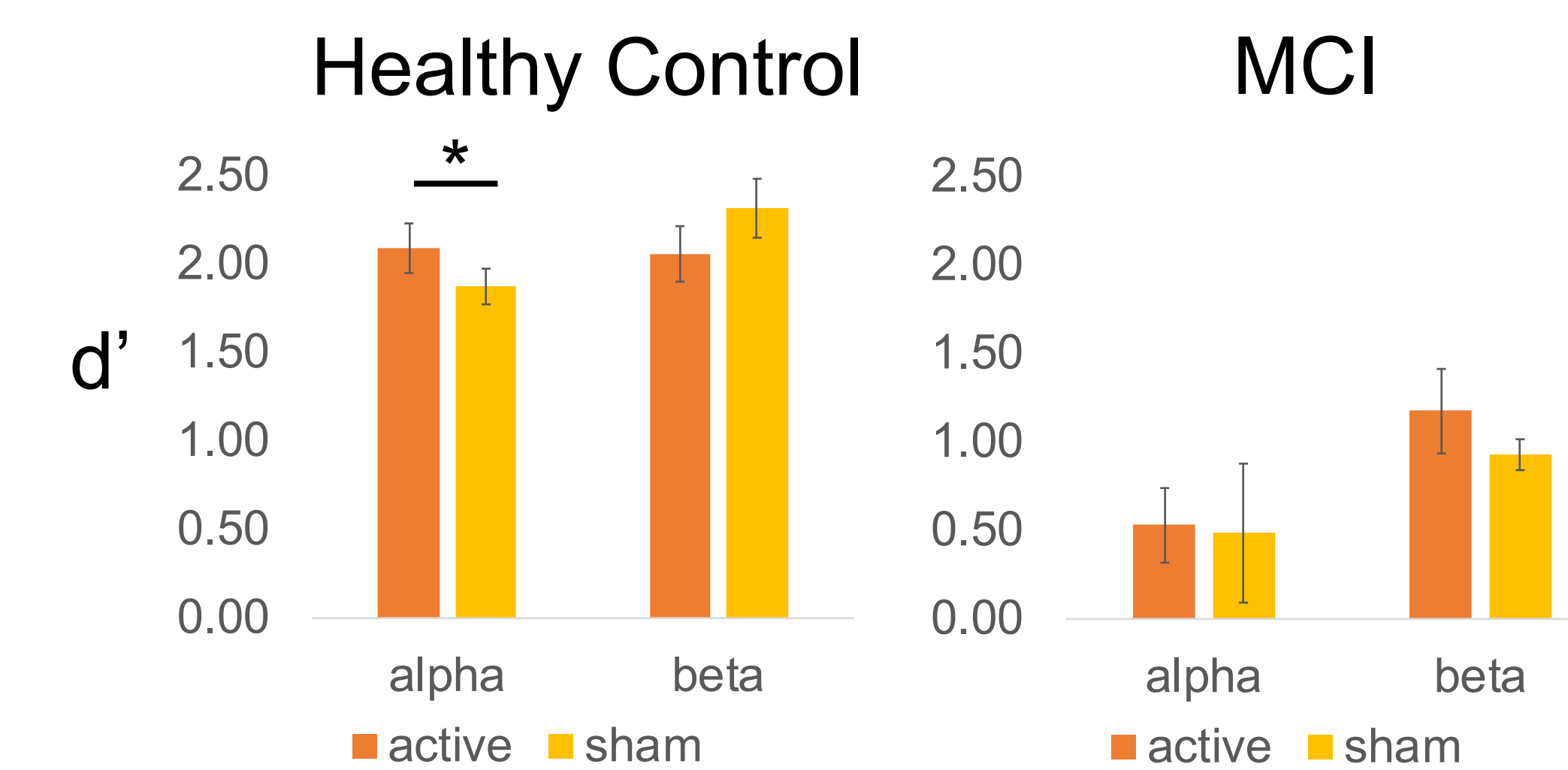

To characterize the bilateral EEG response, we calculate a Laterality Index based on time-frequency power (TFP) within the respective frequency range.

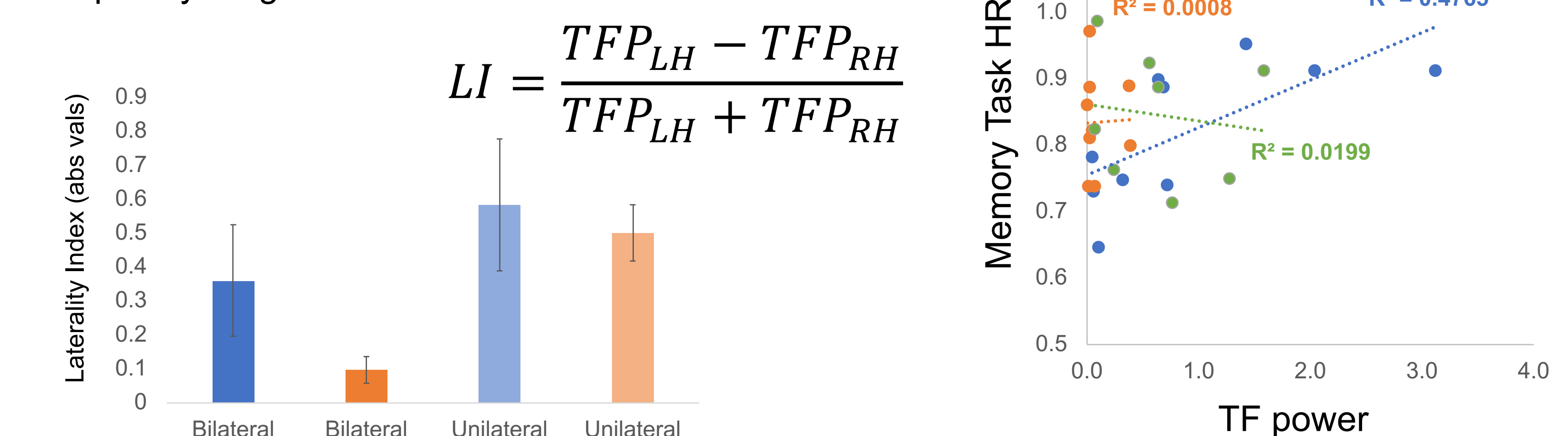

## Can we index subjects' bilateral response to exogenous stimulation?

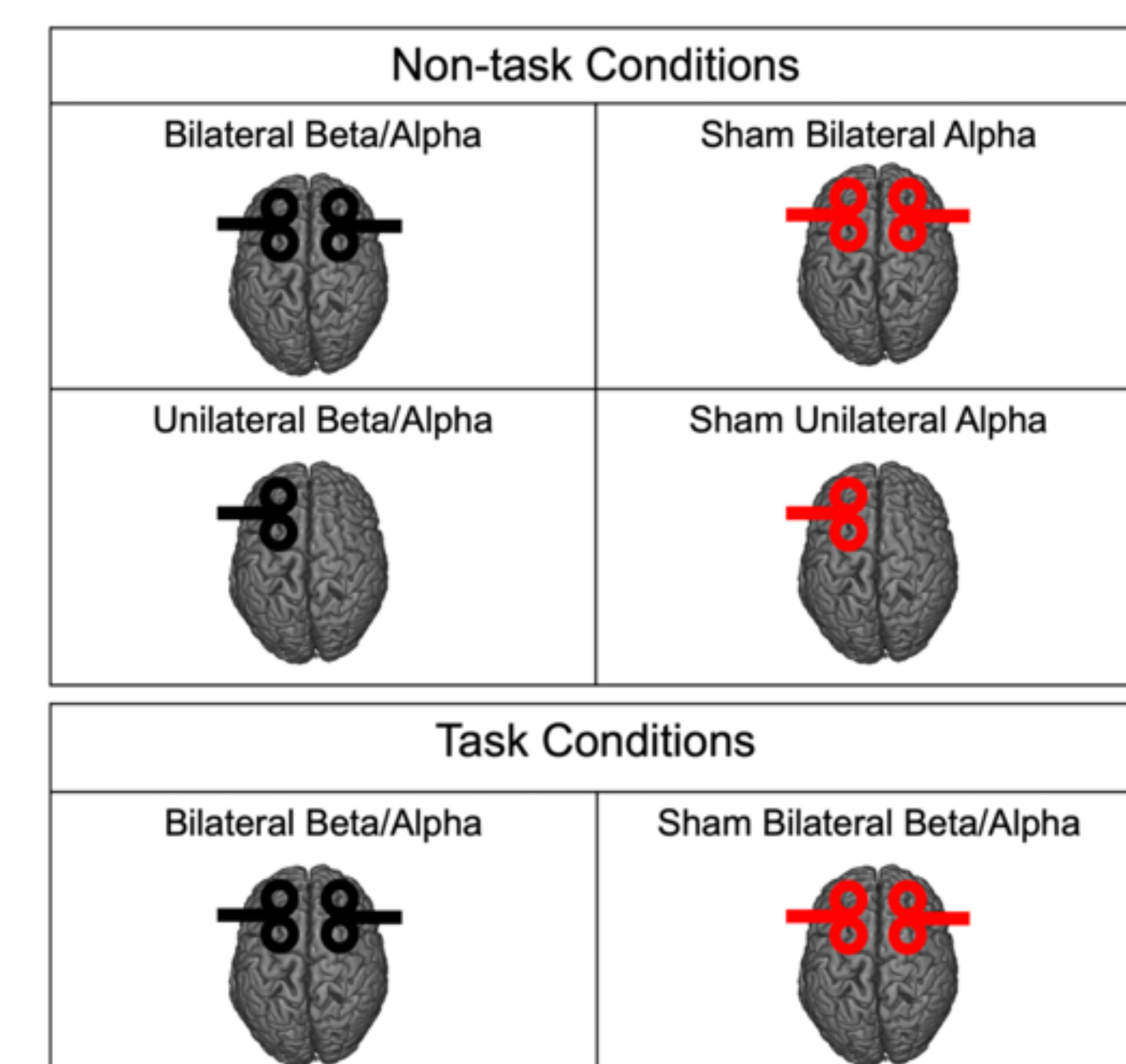

Time frequency plots showing the time range of the TMS pulses and data analyzed for all conditions. The transparent area for the alpha conditions (300ms to 1400ms) and for the beta conditions (300ms to 800ms) marks the period containing the TMS artifact.



Electrodes analyzed

We used neuronavigation viaBrainsight to locate the middle frontal gyrus of individual MRIs.

Two stimulation frequencies:  
Beta = 18 hz  
Alpha = 8 hz

### Time-Frequency Analysis

#### Alpha rTMS (8.8Hz, 10 pulses, 70% AMT)

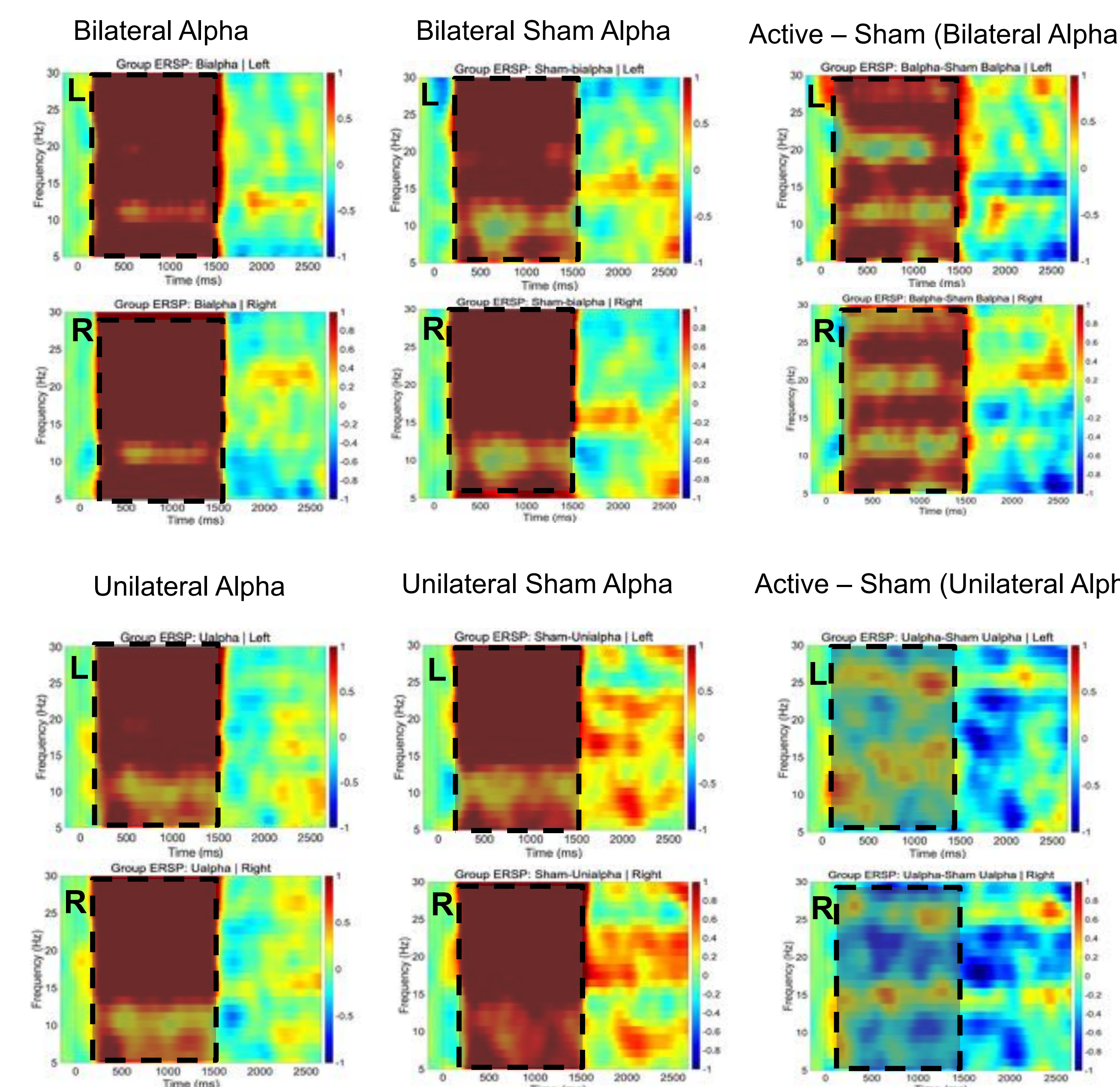

Bilateral stimulation evokes more widespread TF power than unilateral stimulation within both the alpha and beta frequency ranges.

#### Beta rTMS (18.7Hz, 10 pulses, 70%AMT)

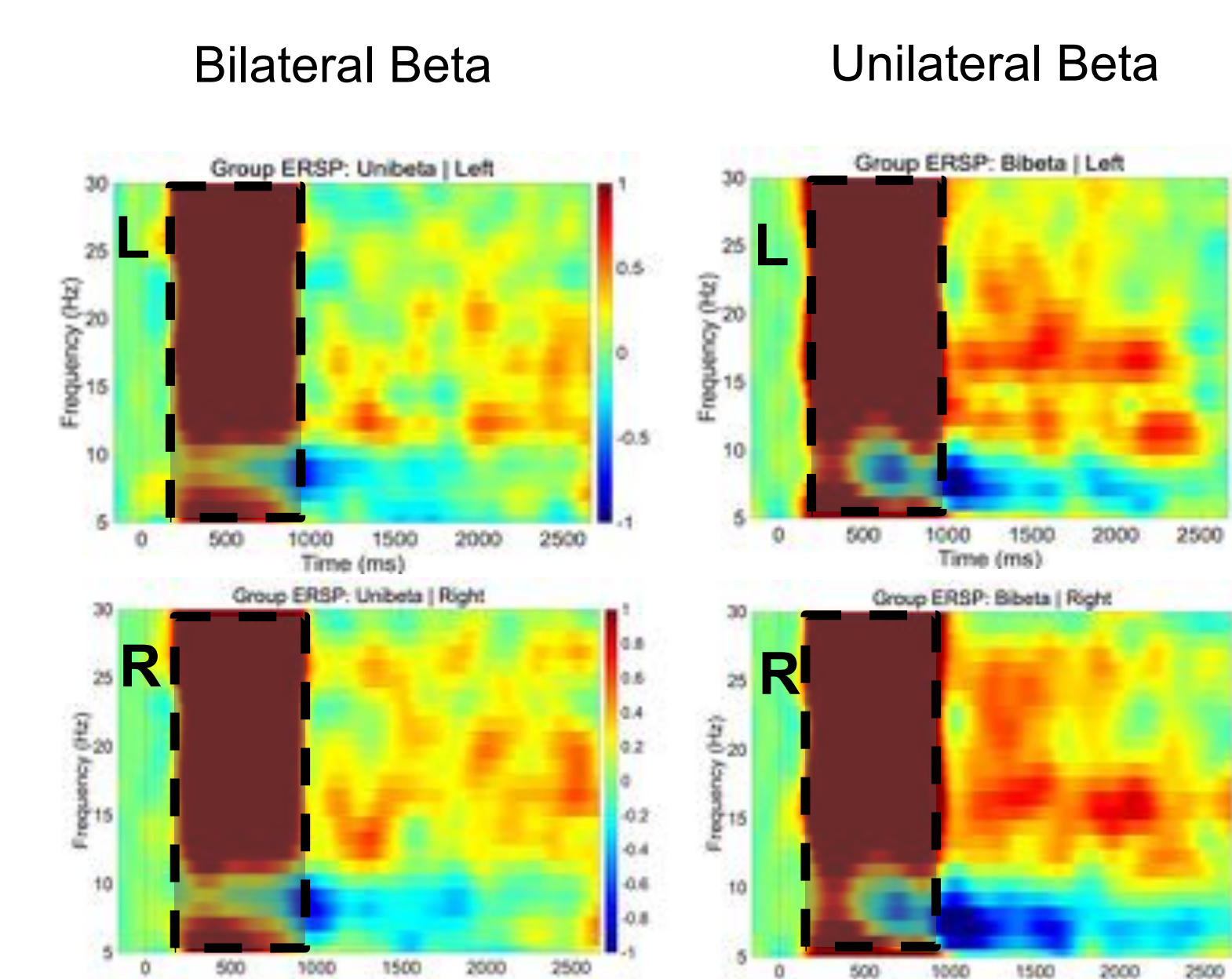

This increase is specific to the frequency train applied, e.g. alpha entrainment for 8Hz rTMS, beta entrainment for 18Hz rTMS.

## Summary

Our study, thus far, helps to confirm the hypothesis that bilateral connectivity patterns mediate attention and memory tasks, and clarify the interdependence between these forms of cognition in older adults.

## References

[1] Cabeza, R. 2002. Hemispheric asymmetry reduction in old adults: The HAROLD Model. *Psychol. Aging* 17: 85–100.  
[2] Davis SW, Murphy DM, Luber BL, Lisanby SH, Cabeza R. Frequency-specific neuromodulation of local and distant connectivity in aging and episodic memory function. *Human Brain Mapping*. 00:00–00  
Funded by NIA grant K01-AG053539